



**AUTOMOTIVE
MANUFACTURING
CURING EQUIPMENT**



— PERFORMANCE ABOVE ALL —

THE STORY

Every story has a hero

IRT started exploring short wave IR techniques back in 1967, this is our story:

THE HERO: The gold coated reflectors combined with ventilation, gives +20.000 operating hours/lamp

THE GOAL: Building know-how, obtaining experience from every application in every industry

THE OBSTACLE: Concentrating short-wave IR to the correct place without waste

THE MORAL: Keeping it effective; used correctly our technique will save energy and production hours

...and yes, we did invent IRT drying technique...

IRT CONTROL UNIT

The IRT control unit is equipped with advanced technology such as temperature measurement, laser and ultra sonic distance sensor. The functions are easy to understand and use. There is a program for each heating requirement. 18 different languages available.



Self instructive menus

- Select a program
- Start curing

Safe and easy to use

12 default programs for:

- Putty
- Filler/waterfiller
- Basecoat/waterbase
- Topcoat
- Clearcoat
- Filler/topcoat/clearcoat on plastic parts
- Final boost
- Soft cure
- + 3 non-set programs

Flexible

- 18 languages
- Edit program position
- Edit program name

Individual use

Edit drying parameters:

- Flash off (evaporation)
- Full bake (final curing)

Process control of:

- Time (min.)
- Temperature increase/min
- Maximum temperature allowed

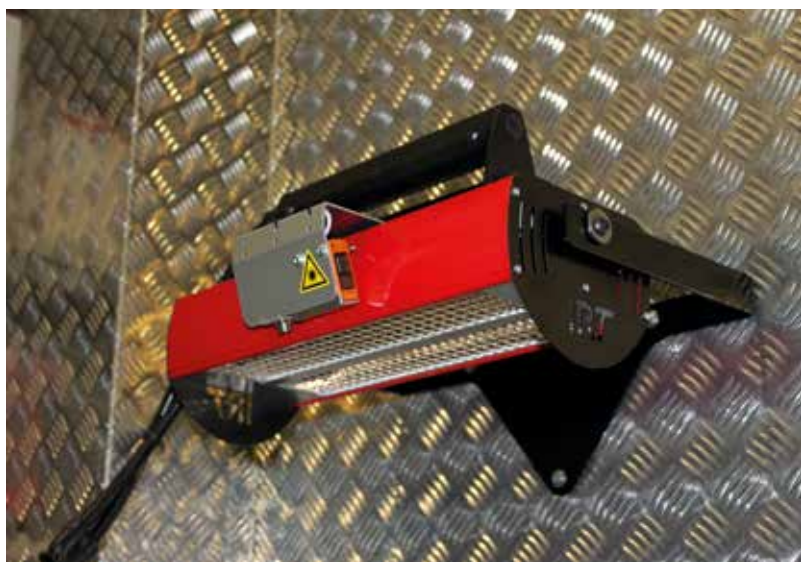

Assembly line installations, roof heaters, spot repair solutions

Unlimited amount of solutions for requested reach, effect, time, ease-of-operation, monitoring, reporting. Heaters installed in rail systems, on floor mounted mobiles and wall mounted.

SAFETY AND CERTIFICATION

Worldwide certification

For your safety, we make sure all our products are certified, no matter where in the world you decide to use the equipment. We are always up-to-date with all European and US standards and are ISO certified since 1998.

Our global network of distributors assist on a national level with installation and service hubs in many countries. Several of our products are certified according to national legislations such as Swedish SP and German GS testing.

Simply put, we can offer an unrivalled combination of experience and legislation certificates that will keep everyone in the project group satisfied:

- ETL: US Conformation
- GS: Geprüfte Sicherheit DGUV Test
- ISO 9001/ISO 14001: Quality and Environmental Certification
- CE: European Machine Directive Certification

IRT technique is the solution for heating projects where reliability and process safety are important parameters.

- Our products start at the exact requested instant
- The exact requested temperature is reached within predetermined time
- The pre-programmed heating curves are followed to the last detail
- The heating process is ended at the exact requested output result

IRT technique even monitors other processes in your assembly to shut down the heating system if there is a stop somewhere else. No waste of energy or overheating of parts.

- Surveillance system: Thermal sensors monitor and alert. This system will react to overheating and other deviations from the set process.
- Curing Analyzer: Registers the process, second by second and reports in easy-to-use graphs. Will help to quickly isolate situations alerted by the thermal sensors. Form a great tool to track and prove energy consumption. All info is logged and can be exported to the post data analyzing tool in excel for report purposes. Live data software available for PC via bluetooth or cable.
- Pyrometers: Pyrometers are used to optimize heat transfer and control every process detail, every second, not too fast, not too hot...
- Ventilation: ventilated cassettes and no hot parts.



POWERCURE

Controlled drying that saves energy, time and space

PowerCure cures completely from inside out. The car can be processed further immediately after cool down with improved throughput of cars as a result. The front and backs are reached with angled wings. PowerCure detects the starting position and saves energy by only activating the necessary IR lamps.



PowerCure, version XL

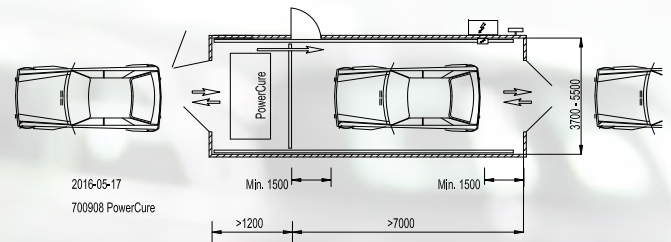

“ Save space and improve throughput. The car is ready to move forward in minutes.”

- No pre-heating of emitters necessary
- Operates across several stations
- Integrated laser sensors for exact positioning
- Integrated ventilation system protects electronics and lamps
- All standard zones pre-programmed
- Hassle free operation with more than 20.000 operating hours per lamp

Selection of panels and paint type is done quickly and easily on the touch control panels, user friendly graphics and self instructive menus. The car is ready to move forward in the process in minutes.



SUSPENSION

Flexible solutions to effective drying

IRT transforms advanced curing technology to practical designs based on assembly line requirements.

IRT IR shortwave and UV solutions need very little space compared to other dryers. Our gold coated FreeForm reflectors guarantee short curing times on large curing areas with even heat distribution and reduced energy consumption.

By irradiating the object rather than the surrounding air, every project is environmentally suitable.

Excellent fit in tight areas and full output in seconds with IRT SingleHeater and Power Cassette configurations.



IR TUNNELS

*Saves energy, time and space
Long experience sets standard for assembly drying*



IR AND UV MOBILES

*Based on a wide range of high quality mobiles with short lead time
Custom-made adaptations on project basis*

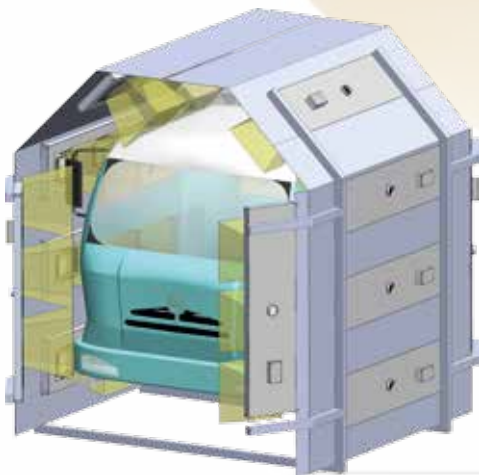

ASSEMBLY LINE INSTALLATIONS

Excellent drying result with individual lamp control



ASSEMBLY LINE INSTALLATIONS

*Environmentally friendly solutions with reduced energy consumption
Short curing times on large curing areas with even heat distribution*



ROOF HEATERS

Horizontal activators
Module built system,
easy to adapt to production changes

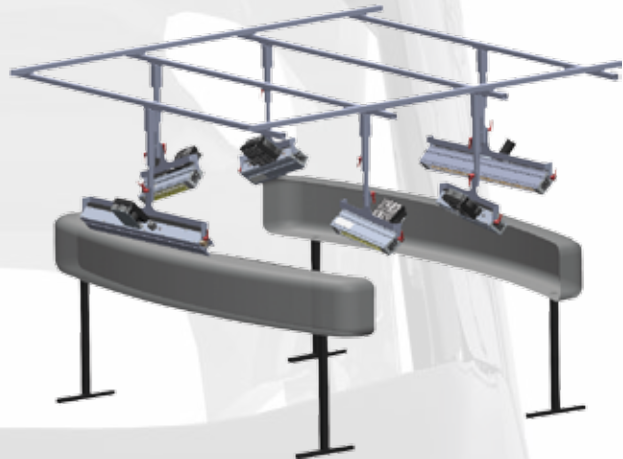

PROJECT INSTALLATIONS

Flexible units
Built-in systems to simplify quick and exact positioning



PROJECT INSTALLATIONS

Extensive experience in custom made variations
based on our wide range of basic dryers and rails
Short and long track solutions with extreme space
efficiency



ROBOTIC INSTALLATIONS

Customized solutions



SWING ARM SOLUTIONS

Simple and space saving curing with a fixed
floor installation and IRT Hyperion self-balanced
cassette arm curing system
The articulated swing arm spans easily around the
car, with very little dead space. The arm is built in
2 sections, attached in a second pivot point

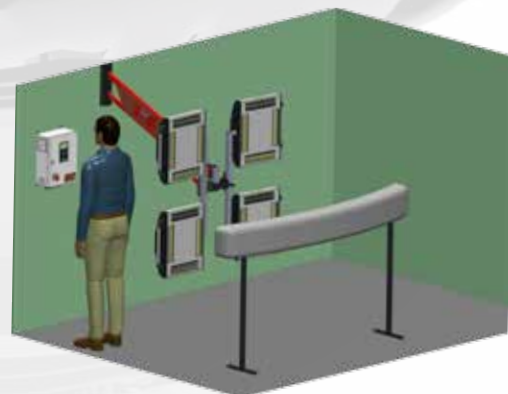

FIXED INSTALLATIONS

Our mobile drying solutions installed on the wall
Audio-visual guidance for correct heat distribution
every time

HIGH TEMPERATURE MOBILE DRYERS

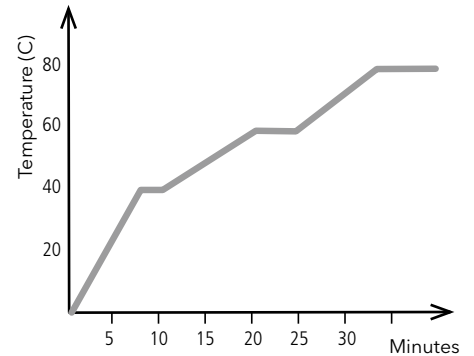

3-step drying cycle for construction glues and panel bonding

A perfect result up to 200° C

The DTP models are designed for “spot repair” and curing of high temperature paint material, up to 200°C/390F. The DTP range is also suitable for curing paint repairs on A-B-C pillars and sills where the steel material is thicker and more power is needed.

Preset processes

A large choice of preset processes are standard, including 3-step panel bonding. The desired drying process is programmed and the dryer follows these precise settings. The microprocessor reacts instantly, regulating the power output. A laser pointer shows the location where the reading occurs and the ultrasonic sensor measures the distance.

Highest efficiency

The reflector surface is coated with a thin layer of pure 24K gold providing the highest level of heat transfer available. The result is minimal heat loss and low energy consumption. A fan keeps the reflectors and lamps clean and cool, greatly increasing their working life (spans up to more than 20.000 operating hours) as well as increasing operator safety.

Flexible chassis and arm

The chassis construction allows for free passage around and under obstacles. The arm flexibility is optimised to simplify correct positioning. With four unique cassette head designs available as standard, there is a DTP model to cover every production curing requirement.



IRT 424 DTP 4-1



IRT 464 DTP 4-2



IRT 4 HI-BAKE

HiBake is a manual alternative to the DTP model, with 50% flash-off, 100% fullbake.

STANDARD FEATURES ON ALL DTP MODELS:

- Automatic temperature control
- Automatic distance measuring
- Laser pointer (with option to operate manually)
- Fan cooled cassette heads
- 18 languages
- 15 process programs (customizable)

Options:

- Live Data Collector
- Post Data Curing Analyzer
- Double pyrometer on twin cassettes



CUSTOMIZED SOLUTIONS

DTP models can be equipped with a double pyrometer option to allow for easier adjustment. With a master pyrometer option on both cassettes you can reach even the most awkward positions on the car.

Another option is the possibility to restart the laser to make sure the mobile is still in correct position in case of disturbances.

DTP mobile configuration:

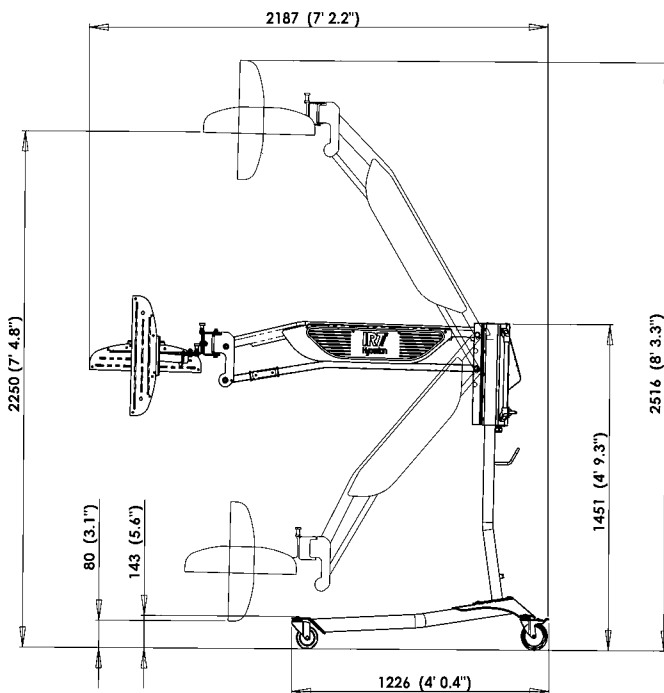

RAIL SYSTEMS

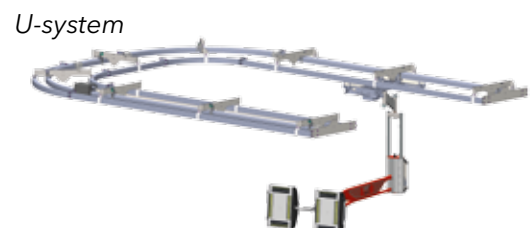
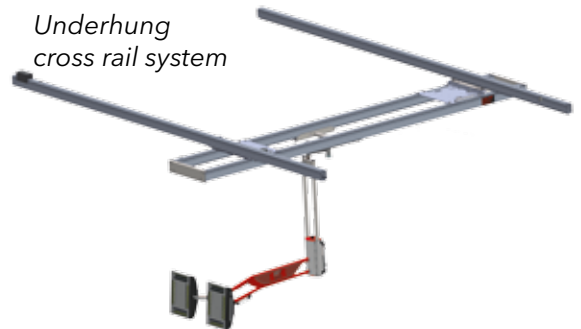

IRT UV CURING

OZONE FREE DESIGN WITH PROTECTIVE GLAS THAT FILTERS UVB/UVC RADIATION

SAFETY

Make sure your equipment is in accordance with EMC/ Low voltage directive and that it is tested by third party with documented time of exposure, safety instructions etc.

THERE SHOULD BE A WARNING SYSTEM FOR EACH LAMP, STATING REMAINING TIME AT FULL EFFECT

ECONOMY

Make sure your equipments lamps has a capacity of >1000 hours. Important parameters are ventilation- and filter quality.

HIGH INTENSITY CAN HELP CURE EVEN WITH OPERATOR MISTAKES, SUCH AS INCORRECT THICKNESS OR DISTANCE

MISTAKES

are human. Make sure your equipment holds high enough intensity, each individual lamp at least 1000 W.

DID YOU KNOW THIS ABOUT UV:

UV light is invisible

We keep visible light in our lamps as guidance.

Quick

UV-curing is very fast, a few minutes suffice.

Not so expensive

Initially more expensive but quickly compensated by low amount of waste and reduced work hours (shorter curing time, less time spent in mixer room).

Metal and plastics

UV works well on plastic parts too, with a very low increase in temperature, the car can be handled further immediately after drying cycle is finalised.

"Correct surface intensity ensures adherence and curing. Minimum 6 mW/cm². I recommend to check this before investing."

Mikael Hansson, R&D Manager, IRT/Hedson

PREPCURE 3 IRT UVA 1

- Designed to cure UVA paint on vertical surfaces
- The cassette is equipped with one UVA lamp and a special designed reflector for the best reflection of the UVA radiation and a superior radiation distribution over the curing area
- The curing time is regulated with a digital timer
- Powerful ventilation and efficient particle filter extends operating life
- Time counter for the lifespan of the UVA lamp

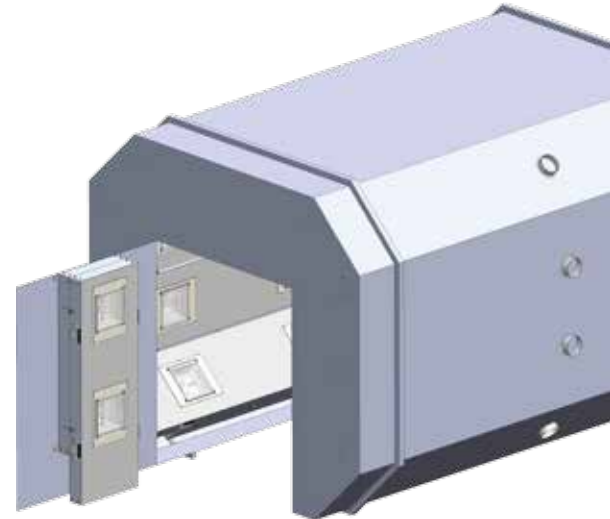

UV drying is not limited to UVA although the safety features differ. Our tunnel configuration is suitable for UVB and UVC solutions.

PREPCURE 4 IRT UVA 1 & 2

- One or two cassettes
- Each cassette is equipped with one UVA lamp and a special designed reflector for the best reflection of the UVA radiation and a superior radiation distribution over the curing area
- The curing time is regulated with a digital timer
- Powerful ventilation and efficient particle filter extends operating life
- Time counter for the lifespan of the UVA lamp
- Easily maneuverable design, combined with a gas spring, simplifies cassette adjustment

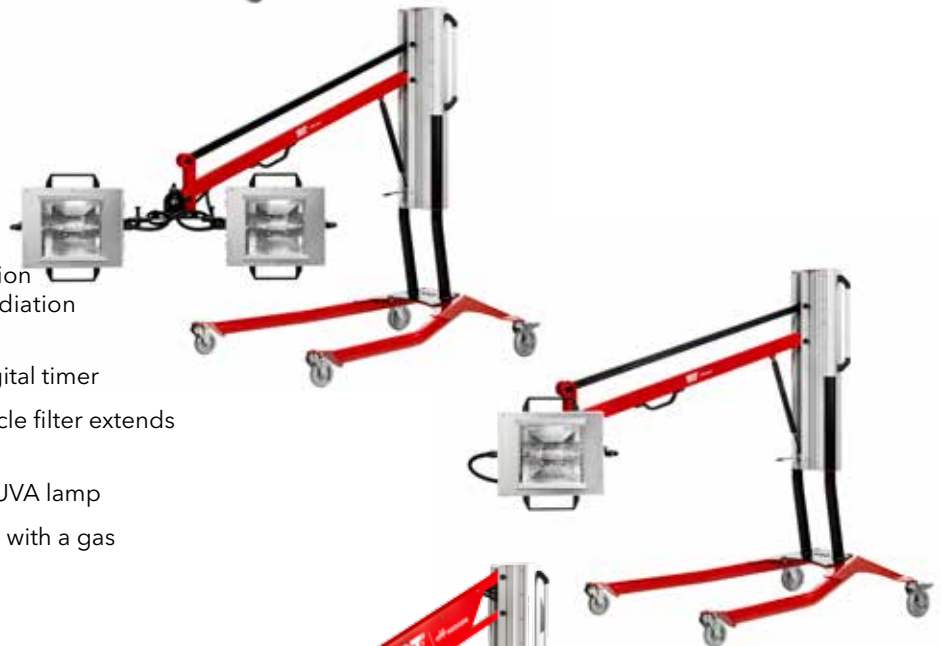

COMBI IRT 4-1 UV/IR

The combination of shortwave infrared and UVA radiation makes this mobile dryer unique. 15 pre-programmed programs for water and solvent based paint material, from putty to clear coat (IR:12, UVA: 3).

- One or two cassettes, includes 4 IR lamps and 1 UVA lamp
- IR and UVA can be run individually and in sequence
- The infrared lamps are mounted in gold surface reflectors, reflecting up to 98% of the short wave radiation
- The IRT control unit includes programme selection
- Time counter for the lifespan of the lamps
- Easily maneuverable design, combined with a gas spring, simplifies cassette adjustment

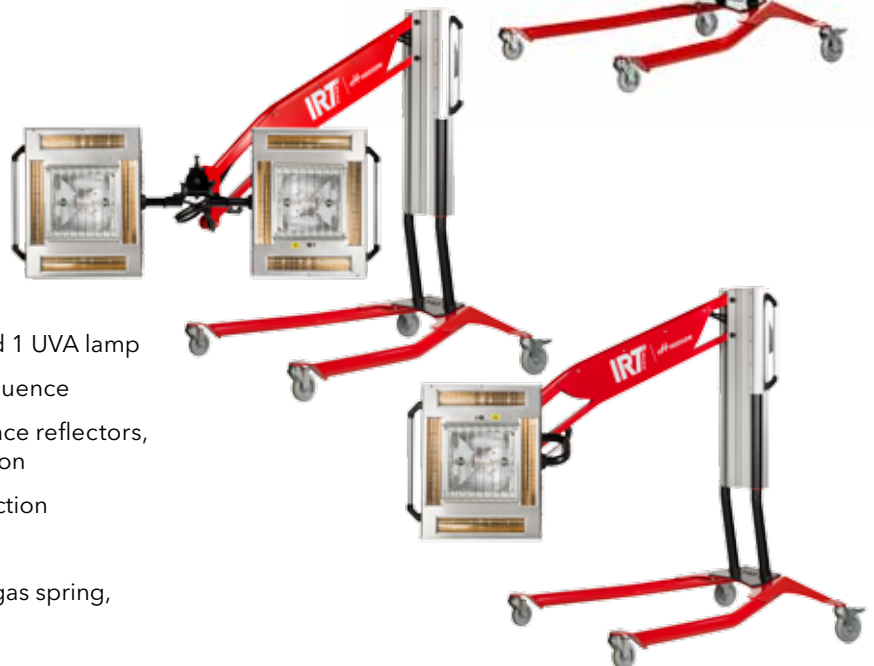

PERFORMANCE ABOVE ALL

Hedson is a leading supplier of premium curing, lifting and cleaning systems for auto workshops and industry worldwide. We come from the land of engineering, and have decades of experience learning from and innovating to real customer needs – technologies that improve the working environment, protect workers and boost productivity. Our ambition to add real measurable values is obvious wherever Hedson solutions are seen, sold or working – from advanced yet easy to use equipment to unmatched customer service, Hedson stands for performance above all.

www.hedson.com

