



# INDUSTRIAL SOLUTIONS



## **SUPERIOR CURING TECHNOLOGY**

No other piece of equipment improves paint finishing production times as dramatically as IRT dryers. IRT is a cost effective and proven technology which ensures 100% dry products before handling.

All IRT dryers use short-wave technology. This, together with the unique range of reflectors such as IRT FreeForm gold coated reflectors, provides the best heat transfer possible.

Short-wave IR has several other advantages. It is easy to control, provides full heat immediately and penetrates the paint completely. The paint cures from the inside and out without retaining solvents and moisture that gives rise to problems with quality. Heat losses to the air are minimal and all energy is transferred to the surface to be dried.

## **HEDSON TECHNOLOGIES**

Hedson Technologies has a history from late 1960's, when we were the first to invent infrared dryers with short-wave IR and in the 1970's we developed spray gun cleaners and pneumatic lifts. Ever since then we have been market leader in the automotive refinishing industry.

With user experiences, innovative technology and well-planned concepts, all Hedson products have one thing in common, to deliver products that meets the high demands of professional customers.

Hedson's products also stand for safety and environmental considerations. They therefore meet international demands and standards in accordance with the Quality Standard ISO-9001 and ISO-14001.

In 2014 Hedson Technologies was acquired by Mellby Gård Innovation och Tillväxt AB, a solid well-known and privately owned Swedish industry investor.

Hedson has a global presence in nearly 80 countries, with offices in Sweden, Germany, France and North America.

## **WHEN YOU ARE GOING TO EQUIP, EQUIP TO WIN.**



A complete infrared IRT-oven has an extremely short conveyer length. Our IRT-Boosters and IRT-Systems fit in very restricted spaces.





## SHORTWAVE INFRARED

5



## CUSTOMIZED IS STANDARD

6

<i>IRT IR/UV combination</i> .....	6	<i>IRT preheating wood surface</i> .....	6
<i>IRT adhesive heating</i> .....	6		
<i>IRT PowerHood</i> .....	6		



## LABORATORY RESOURCES

7

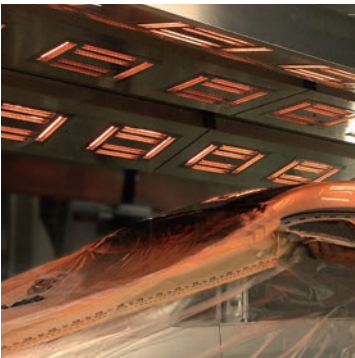

## AUTOMOTIVE INDUSTRY

8

<i>AutoSpot</i> .....	10	<i>Mobile dryers hibake</i> .....	14
<i>MiniSpot</i> .....	10	<i>Rail Systems</i> .....	16
<i>QuickSpot 3</i> .....	11	<i>UV Curing</i> .....	18
<i>QuickSpot 6</i> .....	11	<i>PowerCure</i> .....	20
<i>Mobile dryers lowbake</i> .....	12		



## IRT-BOOSTER

*Paint lines*

22

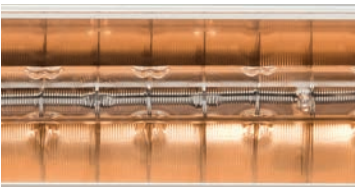

## IRT SINGLEHEATER

*IRT modular system*

24



## PROJECT EXAMPLES

26

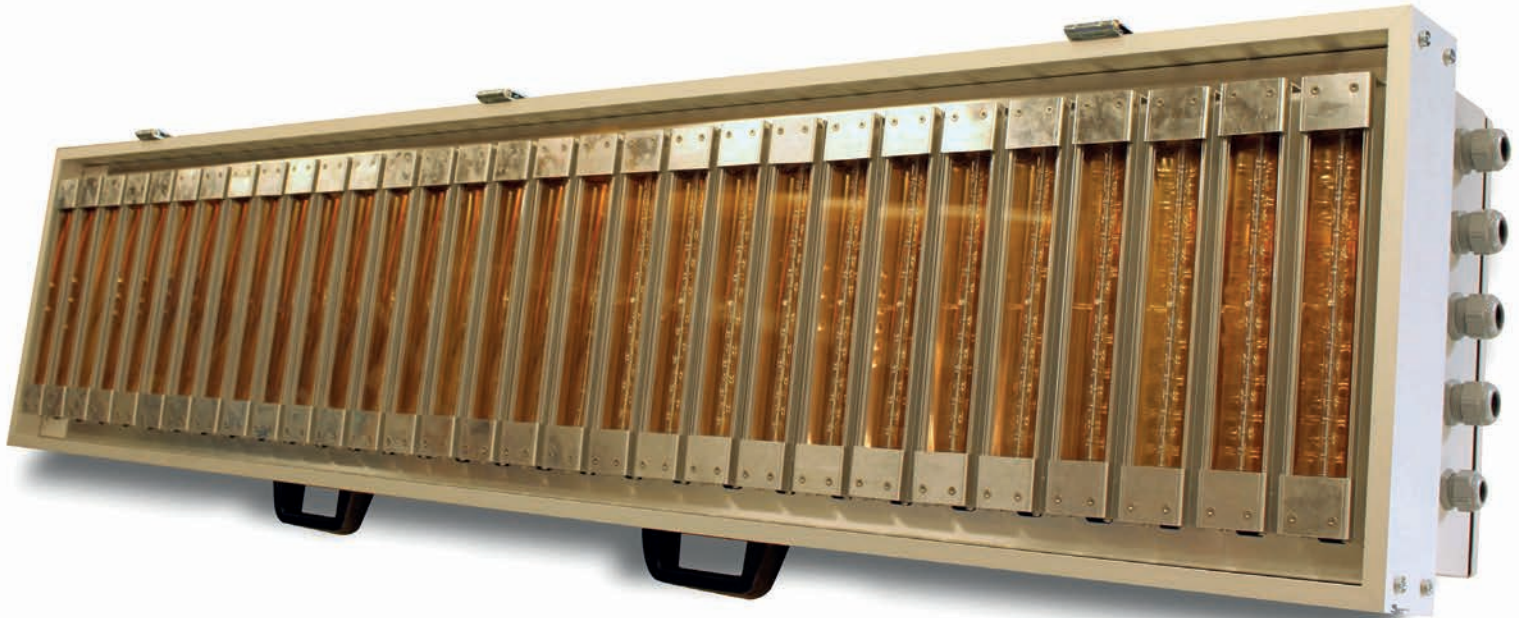

**IRT POWERCASSETTE**

IRT PowerCassettes are configured to application, designed to suit specific customer requirements.

**SAFETY AND CERTIFICATION**

**For your safety, we make sure all our products are certified, no matter where in the world you decide to use the equipment. We are always up-to-date with all European and US standards and are ISO certified since 1998.**

Our global network of distributors assist on a national level with installation and service hubs in many countries. Most of our products are certified according to national standards and third party approved (for example GS, S, ETL).

IRT’s successful combination of theoretical design and practical validation, both in our labs and together with certified third parties, is a strong foundation for high quality products with high performance.

Performance also implies that the product is not only designed to leave smallest possible environmental footprint during usage, but also throughout the entire sourcing process.





## SHORTWAVE INFRARED

By peaking in the shortwave range in combination with highly flexible intelligent software, IRT secures versatile heating transfer advantages for all industry requirements.

- The temperature of the IR emitter gives the IR radiation in shortwave / mediumwave / longwave
- The shortwave range is 0.76-2  $\mu\text{m}$  (appr 3530°C-1170°C)
- Our equipment is in the center of this span to ensure maximum possible shortwave energy within the shortwave range; 1.2  $\mu\text{m}$ , 2170°C

With IRT shortwave technique, you will reach full power within 1 second. That is 0-100% in only 1 second! Unrivalled. And it works with the same precision all through the interval for any power setting. The level of precision is also extremely high in regards to heating the requested surface and not the surroundings, when combined with IRT gold-coated reflectors.

IRT shortwave technique can be configured into electric installations, a comparatively clean form of energy. This is extremely versatile in combination with highly flexible intelligent software to easily adapt to industry requirements. Careful consideration of heating requirements results in effective, high quality finishing and energy consumption savings.

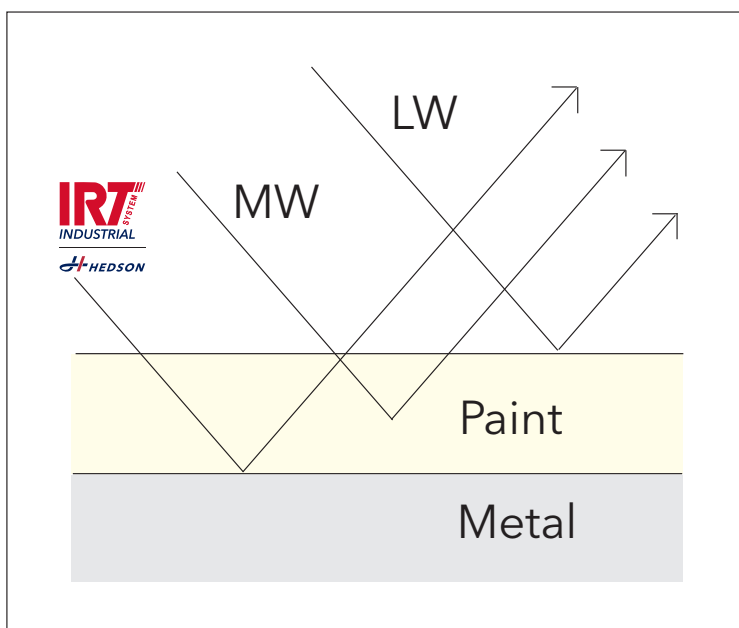

### **Simplified diagram**

Short-wave technique cures from the inside and out, while medium-wave, long-wave and hot air primarily cure the surface.

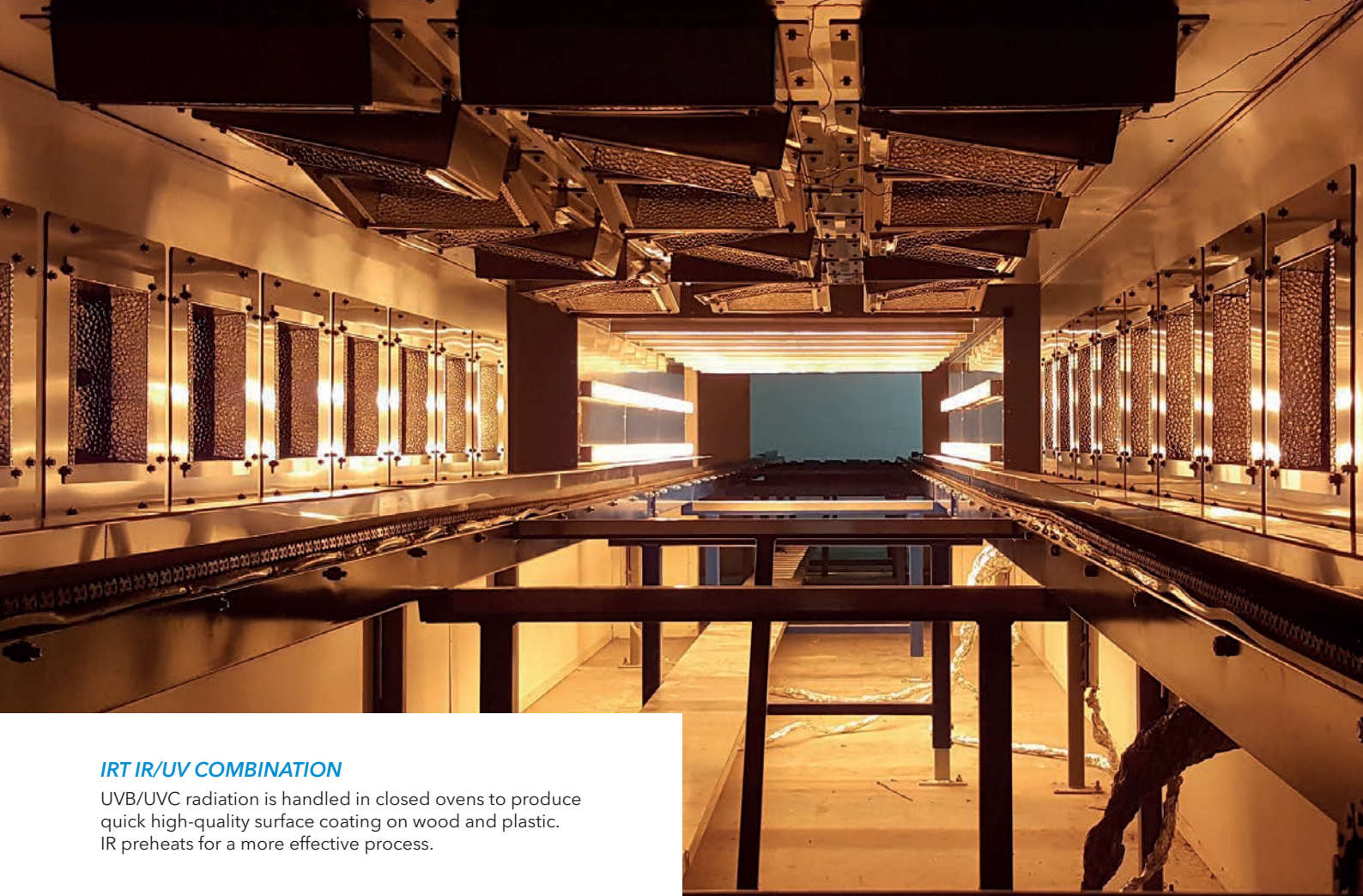

### IRT IR/UV COMBINATION

UVB/UVC radiation is handled in closed ovens to produce quick high-quality surface coating on wood and plastic. IR preheats for a more effective process.



**IRT ADHESIVE HEATING** IRT SingleHeaters are used to cure glue on train tracks to reach perfect adhesion and faster process.

**IRT POWERHOOD, PAPER LAMINATION** IRT PowerHoods are used to carefully monitor the moisture profile on paper and board, the exact right amount of heat is added to create a perfect flat product with an even moisture level.

**IRT PREHEATING WOOD SURFACE** Process speed is increased when IRT technique is used to increase wood surface temperature to optimal surface treatment temperature.

## CUSTOMIZED IS STANDARD

Warp and curl are major causes of produce rejection when laminating paper and board. IRT solutions are used to control the heat/moisture parameters with high precision infrared drying technique, which leads to increased production speed and improved quality.

The timber industry keeps stock outdoors with temperatures as low as -20°C and IRT supplies solutions to increase wood surface temperature to 25°C, which is optimal surface treatment temperature. Process speed is increased without drying out the core of the product.

IRT combined IR/UV solutions create a perfect surface for chromate conversion top coat, preheating with IR and curing with UV. The coating process (Echochrome) is an organic alternative to hexagon chromate surface coating and used on plastic parts for the automotive industry. High-quality surface coating is a strong competitive objective.



# LABORATORY RESOURCES

## Custom-built heat transfer solutions for every industrial sector

Our products are internationally recognized and highly valued. We offer laboratory resources for drying simulation and evaluation, prototype manufacturing, development, design and project resources.

We offer leading edge competence within heat transfer and surface coating with many years of cooperation from a wide range of manufacturing industries.

IRT supplies turnkey projects such as candy coating, heat expansion of parts for the aerospace industry, laminated board flattening and moisture profile monitoring, curing of surface coating on a vast amount of materials and many, many applications for the automotive industry.



**ENERGY CALCULATIONS** Our laboratory tests result in recommended actions for increased efficiency and reduced energy consumption.  
**RESEARCH AND DEVELOPMENT** Vänersborg, Sweden, is the core of our production where the infrared heater and its gold coated reflector was invented (1967).  
**ACCESS TO A HUGE BANK OF EXPERIENCE** Our customers and we ourselves are constantly finding new applications for our versatile and flexible infrared heaters.







## **AUTOMOTIVE INDUSTRY**

High profitability in the automotive industry is obtained by efficient processing. To provide maximum productivity, the best possible use of floor space has to be considered, but also taking into account health and safety regulations.

Based on longterm cooperation IRT has created a customized range of automotive heating equipment. All IRT dryers are based on infrared shortwave technology combined with unique 24 K gold coated reflectors providing the best heat transfer.

A unique combination of product innovation and expertise provides IRT's customers with increased productivity, reduced space requirements and reduced energy consumption.

- IRT drying tunnels
- IRT mobile dryers
- IRT on-line spot repair dryers
- IRT roof heaters

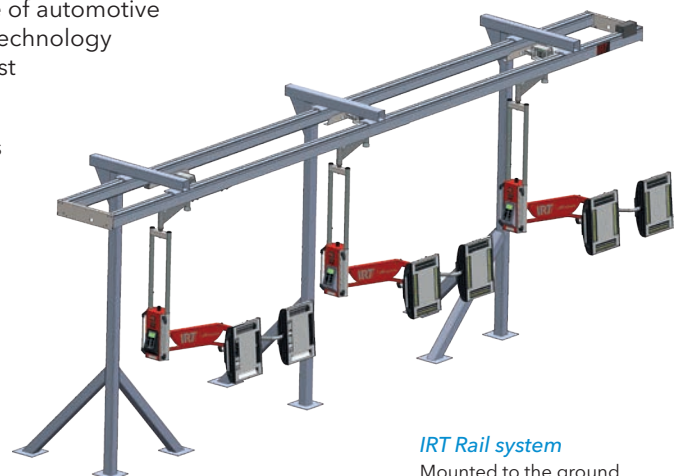

*IRT Rail system*  
Mounted to the ground

## ENDLESS APPLICATIONS

IRT is high performance heat transfer equipment that speeds up the workflow and reduces energy consumption.

Careful consideration of heating requirements results in effective, high quality finishing and energy consumption savings. The applications are endless;

- Drying plastics, drying wax injection, drying anti-corrosion
- Flash-off base coat
- Curing primer/clear coat/decor coat
- Curing roof ditch material
- Embossing interior plastics
- Pre-heating hoods, doors, acoustic dampening mats for hoods
- Heating before disassembling windshields
- Curing windshield glue



*IRT Rail heating*  
With the arm moving vertically

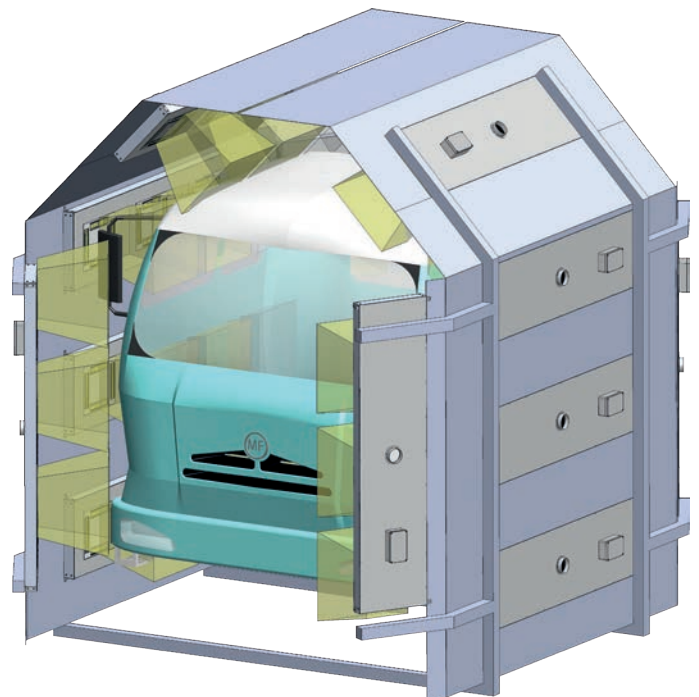

*The IRT Tunnel*  
For heating truck bodies



## IRT FLEXIBLE SPOT REPAIR DRYERS

Efficient solutions that improve the workflow

### IRT AUTOSPOT INFRARED DRYER

- Combine manual and stationary curing for those difficult to reach spaces
- Register and regulate the high-quality curing process for trackable results and energy consumption data
- Process control saves energy, time and space
- 2 kW, 1 Ph

### IRT MINISPOT INFRARED DRYER

- Quick and easy-to-use, on-line and off-line spot repair for small defects etc
- Super small, ergonomic, manual high temperature heater
- Weight 0.8 kg
- Up to 170°C in 30 s\*
- 400 W, 1 Ph

\*On white hood, distance appr 3 cm from surface



IRT AutoSpot



IRT MiniSpot







## IRT QUICKSPOT ON-LINE DRYERS

- Time saving, infrared spot repair in less than 3 minutes
- On-line speed-curing of shallow grain defect spot repairs (up to Ø 5 cm)\*
- Support distances for ergonomic handling
- Space saving; take spot repair on-line
- Process control with self-instructive, easy-to-use default menus
- Retouching finishing repairs in compliance with quality standards

\*Used in combination with a mini spraygun for small size spot repairs



**IRT QUICKSPOT 6 INFRARED DRYER**

6 kW, 3-Ph, 170°-190°C.  
Control unit on mobile parking station.



### HIGH QUALITY SPOT REPAIR

15 seconds: Prep (water sandning)  
67 seconds: 1-2-3 application of base, coat and hardener

**38 SECONDS: IRT QUICKSPOT DRYING (170°C-190°C)**

45 seconds: Cooling to 35°C

15 seconds: Finishing

**TOTAL: 3 MINUTES**



**IRT QUICKSPOT 3 INFRARED DRYER**

3 kW, 1-Ph, 170°-190°C, integrated control unit.  
With mobile parking station.



## **IRT PCAUTO MOBILE DRYERS**

**Suitable for lowbake applications (up to 110°C)**

Environmentally friendly, efficient use of energy with 24 carat gold-coated reflectors and powerful ventilation, giving the lamps a service life of up to 20,000 operating hours.

FreeForm reflectors for an unsurpassed drying surface. Clear display with graphics showing the exact curing process and 15 self-instructive programs for plastic/metal/water/solvent in 18 languages. The arm is self-locking and angled to provide increased reach.

- Automatic temperature control
- Fan cooled cassette heads for increased operator safety
- Laser circle indicates measuring position
- Automatic distance measuring



### CURING AREAS UP TO:

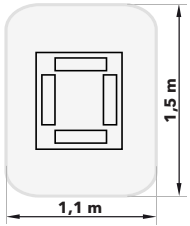

**IRT 4-1 PCAUTO**  
One cassette at a distance of 600 mm, on black sheet metal

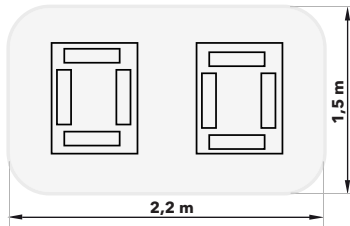

**IRT 4-2 PCAUTO**  
Two cassettes at a distance of 600 mm, on black sheet metal

TECHNICAL DATA IRT 4-1 PCAUTO		
Frequency	50-60 Hz	
Output power	6 kW	
Max. cassette height	2250 mm (h) 2550 mm (v)	
Part.no.	Voltage	Current
800423	400 V, 3 PH, 4 pin, EU	9A
800425	400 V, 3 PH, 5 pin, EU	9A
800421	230 V, 3 PH, EU	15A
800426	400 V, 3 PH, AUS	9A
800485	200 V, 3 PH, 4P, JP	15A
800422	230 V, 1 PH, NA ETL	26A
800468	230 V, 3 PH, NA ETL	15A
800427	440-480 V, 3 PH, NA ETL	9A
800613	440-480 V, 2 PH, NA ETL	13A

TECHNICAL DATA IRT 4-2 PCAUTO		
Frequency	50-60 Hz	
Output power	12 kW	
Max. cassette height	2250 mm (h) 2550 mm (v)	
Part.no.	Voltage	Current
800418	400 V, 3 PH, 4 pin, EU	16A
800400	400 V, 3 PH, 5 pin, EU	16A
800413	230 V, 3 PH, EU	27A
800415	200 V, 3 PH, 4P, JP	27A
800417	400 V, 3 PH, AUS	16A
800411	230 V, 1 PH, NA ETL	48A
800414	230 V, 3 PH, NA ETL	27A
800419	440-480 V, 3 PH, NA ETL	16A
800614	440-480 V, 2 PH, NA ETL	26A

OPTION - IRT DATA COLLECTOR	
Part.no.	Description
750583	USB Cable Data Collector
750584	USB Memory Data Collector
750585	Wireless Data Collector

CONSUMABLES	
Part.no.	Description
102699	Lamp-IR 2 kW 235 V 360 mm
102700	Lamp-IR 1 kW 235 V 360 mm
713576	IRT cassette air filter
713576-10	10 pcs IRT cassette air filter

CURING TIMES	
Putty	5-6 min
Filler, bright	10-15 min
Filler, dark	10-15 min
Waterbase	4-6 min
Base coat	4-8 min
Top coat	10-15 min
Clear coat	10-15 min
Plastic Filler	10-15 min
Plastic top coat	13-17 min
Plastic clear coat	13-17 min
Final boost	2-4 min
Soft cure	13-17 min



IRT 4-1 PcAuto



IRT 4-2 PcAuto





## IRT DTP MOBILE DRYERS

Suitable for hibake applications (up to 200°C)

Designed to cure high temperature paint material and suitable for paint repairs on A-B-C pillars and sills. A large choice of preset processes are standard including 3-step drying cycles. Minimal heat loss, low energy consumption and low maintenance thanks to 24 carat gold coated reflectors and powerful ventilation. Excellent arm flexibility optimizes cassette positioning possibilities.

- Automatic temperature control
- Fan cooled cassette heads for increased operator safety
- Laser pointer indicates the specific reading position
- Automatic distance measuring

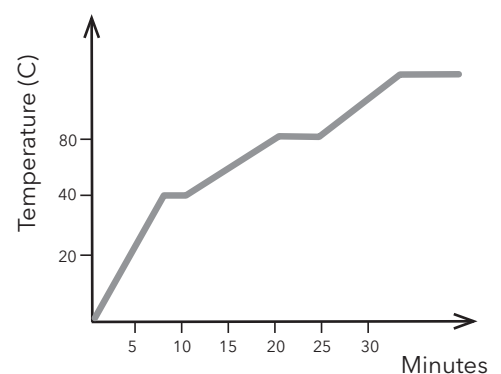

3-step drying cycle for construction glues, steel filler and panel bonding



**IRT 464 DTP 4-1**



**IRT 464 DTP 4-2**



**IRT 424 DTP 4-1**



**IRT 425 DTP 4-1**



**IRT 428 DTP 4-1**



**IRT 424 DTP 4-2  
IRT 425 DTP 4-2  
IRT 428 DTP 4-2**



**CUSTOMIZED SOLUTIONS**

DTP models can be equipped with customized cassettes and many other add-ons such as a double pyrometer option to allow for easier adjustment. With a master pyrometer option on both cassettes you can reach even the most awkward positions on the outside and inside of the car. Another option is the possibility to restart the laser to make sure the mobile is still in correct position in case of disturbances.



**IRT 4 HI-BAKE**

Hi-Bake is a manual alternative to the DTP model, with 50% flash-off, 100% fullbake.

TECHNICAL DATA IRT DTP				
DTP dryer cassette	Drying surface (l x h) =cassette size	No. of cassettes	No. of lamps	Power (kW)
IRT 4 HI-BAKE	300 x 300 mm	1	3	3
IRT 424 DTP 4-1	400 x 300 mm	1	2	4
IRT 424 DTP 4-2	1000 x 300 mm	2	4	8
IRT 425 DTP 4-1	500 x 300 mm	1	2	4
IRT 425 DTP 4-2	1200 x 300 mm	2	4	8
IRT 428 DTP 4-1	800 x 300 mm	1	2	6
IRT 428 DTP 4-2	1800 x 300 mm	2	4	12
IRT 464 DTP 4-1 (6 kW)	600 x 600 mm	1	6	6
IRT 464 DTP 4-1 (10 kW)	600 x 600 mm	1	6	10
IRT 464 DTP 4-2 (12 kW)	1200 x 600 mm	2	12	12
IRT 464 DTP 4-2 (20 kW)	1200 x 600 mm	2	12	20

# ASSEMBLY LINE RAIL SYSTEMS

## Simple and space saving high quality curing rail systems

The rails can be equipped with any number of heaters installed in easy-glide trolleys, on self-balanced cassette arms. Precious space between the vehicles can be saved, and no loose or trailing cables on the floor disturb the work process.

- Rail systems tailor-made to suit different working areas
- Electric power supply integrated into the rails
- Excellent fit in tight areas between cars



## PUT TOGETHER YOUR IRT RAIL SYSTEM

IRT CROSS RAIL SYSTEM	
■	Side Rail
■	Standard Sidehung or Underhung Kit
■	Cross Rail
■	Vertical Arm
■	Rail Dryer
■	Main Switch
■	Dust cover (spray booth only)
IRT RAIL SYSTEM WITHOUT CROSS RAIL	
WALL OR CEILING MOUNTED	
■	Side Rail
■	Suspension kit for wall or ceiling
■	Trolley cpl
■	Vertical Arm
■	Rail Dryer
■	Main Switch
■	Dust cover (spray booth only)

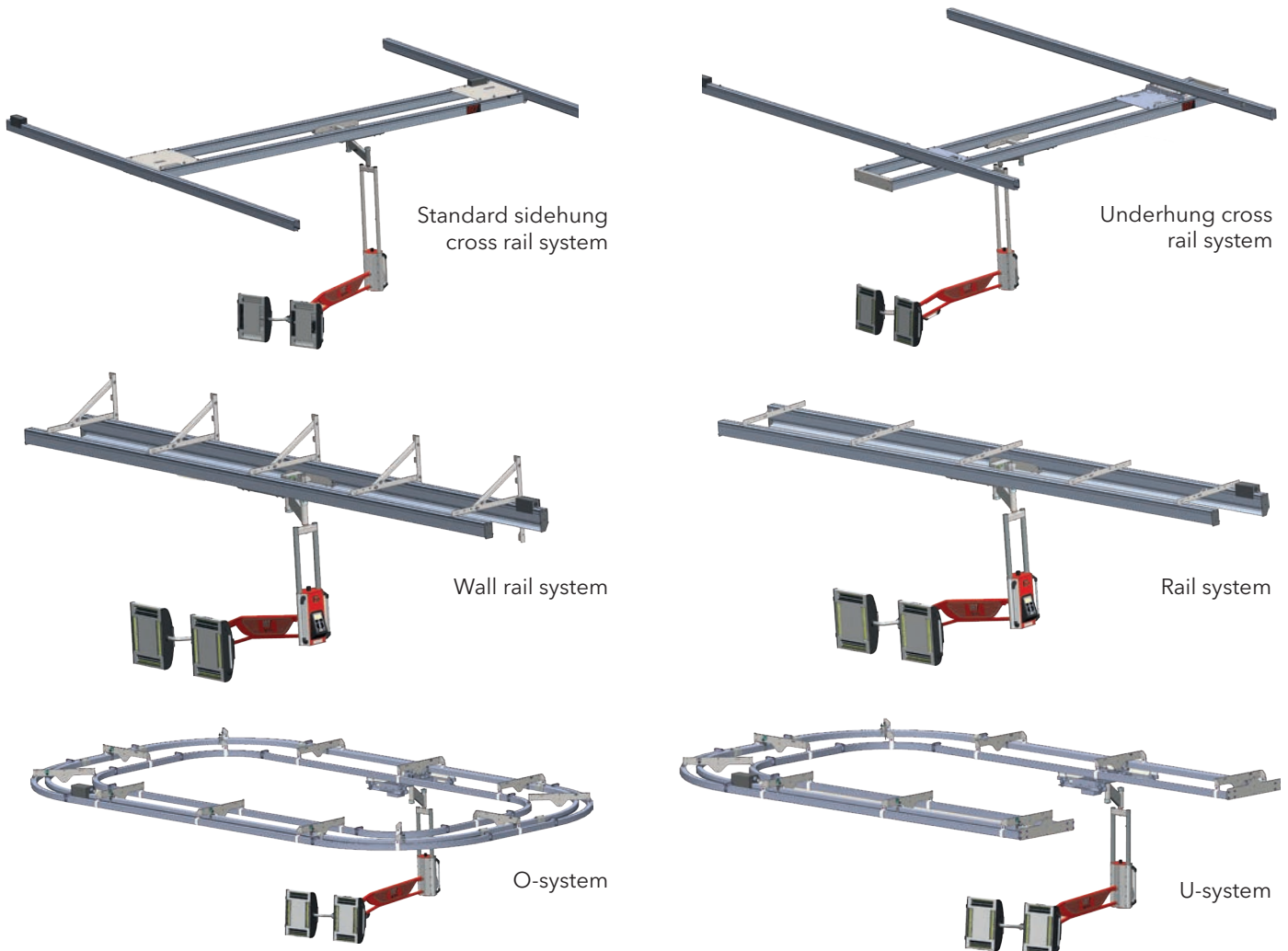



# IRT RAIL SYSTEMS

SIDE RAILS SET			
<i>Can be loaded with 100 A = 12 pcs of 400-480 V cassettes or 6 pcs of 230 V cassettes</i>		<i>Can be loaded with 200 A (2 x 100 A) = 24 pcs of 400-480V cassettes or 12 pcs of 230 V cassettes</i>	
Part.no.	Description	Part.no.	Description
711986	0-4 m, Rail bolt 8 pcs	712234	10-11 m
711987	4-5 m, Rail bolt 10 pcs	712268	11-12 m
711988	5-6 m, Rail bolt 10 pcs	712269	12-13 m
711989	6-7 m, Rail bolt 12 pcs	712270	13-14 m
711990	7-8 m, Rail bolt 14 pcs	712271	14-15 m
711991	8-9 m, Rail bolt 14 pcs	712272	15-16 m
711992	9-10 m, Rail bolt 16 pcs	712273	16-17 m
711993	10-11 m, Rail bolt 18 pcs	712274	17-18 m
711994	11-12 m, Rail bolt 18 pcs	712275	18-19 m
711995	12-13 m, Rail bolt 20 pcs	712276	19-20 m
711996	13-14 m, Rail bolt 22 pcs	712308	20 m and above
711997	14-15 m, Rail bolt 22 pcs		
711998	15-16 m, Rail bolt 24 pcs		
711999	16-17 m, Rail bolt 24 pcs		
712000	17-18 m, Rail bolt 26 pcs		
712001	18-19 m, Rail bolt 26 pcs		
712002	19-20 m, Rail bolt 28 pcs		
712079	20-22 m, Rail bolt 32 pcs		
712080	22-24 m, Rail bolt 34 pcs		
712081	24-26 m, Rail bolt 38 pcs		
712082	26-28 m, Rail bolt 40 pcs		
712083	28-30 m, Rail bolt 42 pcs		
714811	30-34 m, Rail bolt 46 pcs		

SIDEHUNG / UNDERHUNG CROSS RAIL KIT	
Part.no.	Description
714586	Underhung cross rail kit
714587	Sidehung cross rail kit (Standard)

CROSS RAIL SET (INCL. SWINGARM)	
<b>400-480 V, 3 Ph</b>	
Part.no.	Description
713934	0-4 m
713935	4-5 m
713936	5-6 m
713937	6-7 m
<b>230 V, 3 Ph</b>	
Part.no.	Description
713938	0-4 m
713939	4-5 m
713940	5-6 m
713941	6-7 m

MAIN SWITCHES	
Part.no.	Description
121512	32 A 230 V < 2 cassettes 400-480 V < 4 cassettes
121806	63 A 230 V < 4 cassettes 400-480 V < 8 cassettes
190146	100 A 230 V < 6 cassettes 400-480 V < 12 cassettes

TECHNICAL DATA RAIL DRYERS		
Part.no.	IRT 3-20 PcD	Current
800463	IRT 3-20 PcD: 400 V, 3 Ph, 6 kW (EU)	9A
800477	IRT 3-20 PcD: 230 V 3 Ph 6 kW (EU, JP)	15A
Part.no.	IRT 4-10 PcAuto	
800489	400 V 3 Ph 6 kW (EU)	9A
800525	230 V 3 Ph 6 kW (NA, ETL)	15A
800494	480 V 3 Ph 6 kW (NA, ETL)	9A
Part.no.	IRT 4-20 PcAuto	
800464	400 V 3 Ph 12 kW (EU)	17A
800480	230 V 3 Ph 12 kW (EU, JP)	30A
800479	480 V 3 Ph 12 kW (NA, ETL)	17A
800498	230 V 3 Ph 12 kW (NA, ETL)	30A
Part.no.	IRT COMBI 4-10 IR-UVA	
800618	400 V 3 Ph IR: 6 kW UVA: 1.2 kW (EU)	9A
Part.no.	IRT COMBI 4-20 IR-UVA	
800619	400 V 3 Ph IR: 12 kW UVA: 2.4 kW (EU)	17A

SUSPENSION KIT FOR INSTALLATION	
Part.no.	Description
714719	Wall system, 1pc Siderail Rail bolt / 2
714721	Rail system, 1pc Siderail Rail bolt / 2

RAIL EXTENSION KIT	
Part.no.	Description
190057	0-4 m
190058	4-6 m
190059	6-7 m
190060	Splice kit

DUST COVER	
Part.no.	Description
800664	Dust cover wall mounted (IRT 3-10 and 4-10)
800665	Dust cover wall mounted (IRT 3-20 and 4-20)

DUST COVER AND SURVEILLANCE SYSTEM	
Part.no.	Description
800597	Dust cover and Surveillance System (only for spray booth), incl. 800154 400 V, 3 Ph (not ETL), 2 cassettes

VERTICAL ARM (INSTALLATION HEIGHT)	
Part.no.	Description
713990	2.25 to 3.40 m*
713910	2.25 to 3.15 m**
713911	2.25 to 2.7 m***
<i>For COMBI IR-UVA: *2.65-3.40 **2.65-3.15 ***2.65-2.70</i>	

WALL BRACKETS FOR INSTALLATION OF A SIDE RAIL TO A WALL	
Part.no.	Description
800154	Wall brackets, 14 pcs
710222	Wall bracket, 1 pc

TROLLEY CPL	
Part.no.	Description
714724	Trolley for wall or ceiling mounted rail system (Quantity: 1/dryer)



**ALWAYS USE SAFETY GLASSES WHEN HANDLING UV LIGHT.  
WE SUPPLY A PAIR WITH EACH DELIVERED UNIT.**

## **IRT UVA**

### **Mobile UVA dryers with high intensity and outstanding curing performance of UVA paint materials**

A mobile UVA dryer is an essential aid when curing UVA paint material on small and medium sized areas. The IRT UVA dryer works with UVA radiation. The ultraviolet light spectrum generated by the UVA-lamp interacts with special coating chemistries to produce a high-quality, durable curing.

Most importantly to achieve a good and fast curing result there must be enough UVA intensity. Our UVA products have an outstanding intensity to achieve the best curing result, even curing thick filler layers without problems. Our easily manoeuvrable combined IR/UVA models are equipped with one or two compact high efficiency 1200 W UVA-lamps which make the curing extremely fast and can be run individually or in sequence. The combined models have IRT control units with programme selection allowing quick

access to a range of pre-set applications. Our UVA lamp design is ozone-free with protective glass that filters UVB/UVC-radiation.

- Third party UV safety report (EN62471) for operator safety
- Ozone-free lamp design with protective glass that filters UVB/UVC-radiation
- High-quality and durable curing

# COMBINATION OF IR AND UVA CURING

## Unique mobile dryers with a combination of shortwave infrared and UVA radiation

The combination of shortwave infrared and UVA radiation makes this mobile dryer unique. One cassette includes 4 IR lamps and 1 UVA lamp. These mobile UV dryers are featured with 15 (IR: 12, UV: 3) pre-programmed programs for water and solvent based paint material, from putty to clear coat.

- IR and UVA can be run individually and in sequence
- The infrared lamps are mounted in gold surface reflectors, reflecting up to 98% of the short-wave radiation
- The IRT control unit includes programme selection
- Time counter for the life length of the lamps

### CURING AREAS UVA:

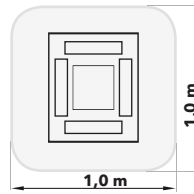

**IRT COMBI 4-1 IR-UVA**  
1 cassette at a distance of 550 mm with a UVA intensity of 25 mW/cm<sup>2</sup>

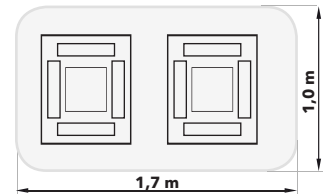

**IRT COMBI 4-2 IR-UVA**  
2 cassettes at a distance of 550 mm with a UVA intensity of 25 mW/cm<sup>2</sup>

### CURING AREAS IR UP TO:



**IRT COMBI 4-1 IR-UVA**  
1 cassette at a distance of 600 mm, on black sheet metal

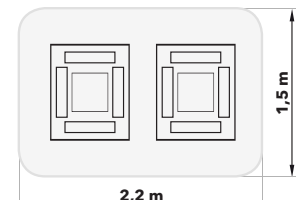

**IRT COMBI 4-2 IR-UVA**  
2 cassettes at a distance of 600 mm, on black sheet metal

TECHNICAL DATA		
	IRT Combi 4-1 IR-UVA	IRT Combi 4-2 IR-UVA
<b>Voltage</b>	380-420 V, 3 Ph/PE	380-420 V, 3 Ph/PE
<b>Frequency</b>	50 Hz	50 Hz
<b>Power</b>	IR: 6 kW, UVA: 1.2 kW	IR: 12 kW, UVA: 2.4 kW
<b>Fuse</b>	10 A	16 A
<b>Current</b>	IR: 9 A, UVA: 3 A	IR: 16 A, UVA: 6 A
<b>Max. cassette height</b>	2240 mm	2240 mm
<b>Part.no.</b>	800605	800606

CONSUMABLES	
Part.no.	Description
102699	Lamp-IR 2 kW 235 V 360 mm
102700	Lamp-IR 1 kW 235 V 360 mm
712894	Air filter for UVA
712894-10	10 pcs air filter pack UVA
714842	UV-lamp replacement kit 400 V 1.2 kW (Combi IR-UVA)
129070	UV/IR Safety glasses
713576	IR cassette air filter
713576-10	10 pcs IR cassette air filter



IRT Combi 4-1 IR-UVA



IRT Combi 4-2 IR-UVA





*PowerCure special version XL*

## **POWERCURE**

### **Controlled infrared arch configuration that saves energy, time and space**

IRT PowerCure cures completely from inside out. The car can be processed further immediately with improved throughput as a result. The front and backs are reached with angled wings. IRT PowerCure detects the starting position and saves energy by only activating the necessary IR lamps.

- Save space and improve throughput, ready to move forward in minutes
- Hassle free operation with more than 20,000 operating hours per lamp
- All standard zones pre-programmed
- No pre-heating of emitters necessary
- Integrated laser sensors for exact positioning
- Integrated ventilation systems

**DIMENSIONS**

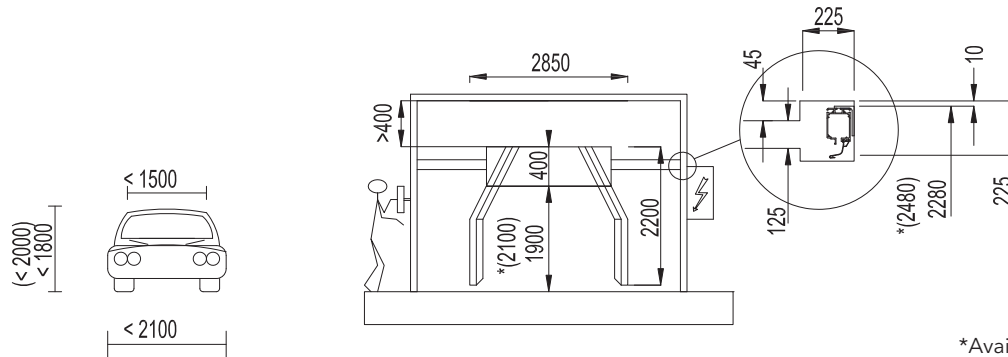

\*Available height option

**IRT POWERCURE  
SINGLE**

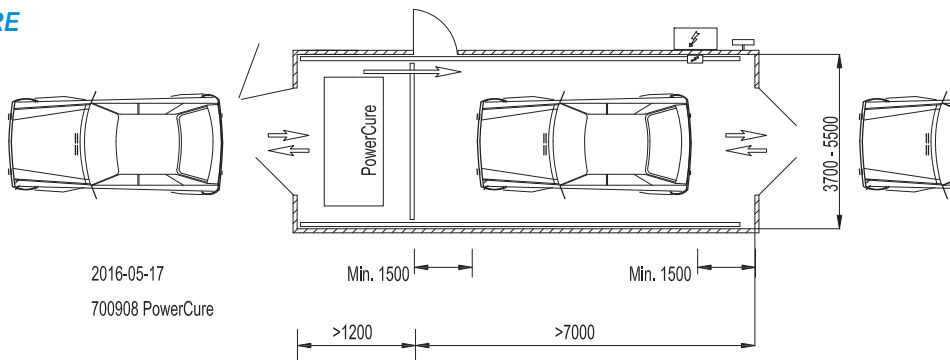

**IRT POWERCURE  
DOUBLE**

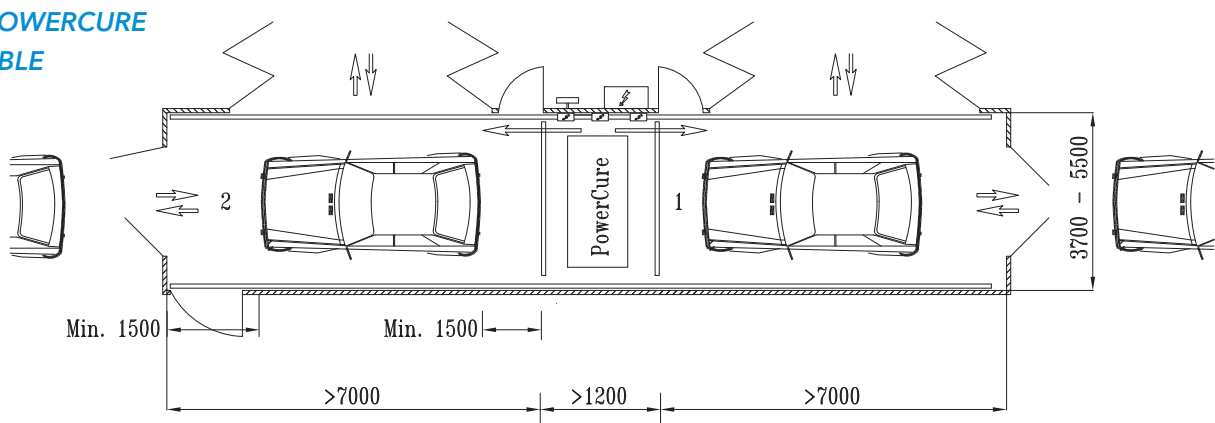

TECHNICAL DATA		
<b>Installed power</b>	54 kW/63 A (20 lamps à 3 kW less 6 kW supply voltage compensation)	
<b>Voltage</b>	400 V, 3 Ph ~/PE	
<b>Frequency</b>	50-60 Hz	
CURING TIMES		
<i>Medium-sized vehicles</i>		
	Base coat (appr)	Clear coat (appr)
<b>Bonnet</b>	4 min	7 min
<b>Door</b>	3 min	5 min



Selection of panels and paint type is done quickly and easily on the touch control panels with user friendly graphics and self-instructive menus.





## **IRT-BOOSTER, PAINT LINES**

### **Increased production rate and reduced energy consumption**

IRT-Boosters can be combined with most traditional curing methods. An infrared IRT-Booster can be placed before convection- and drying ovens in all types of conveyor wet/dry paint processes. High-precision, effective increase of object temperature leads to increased production rate, reduced energy consumption and solves quality issues.

- Obtain complete control over the object surface temperature
- Full output in seconds, programme to any type of thermal cycle
- Easily retrofits onto existing ovens
- Increased production rate with effective heating
- No need to slow down for extraordinary goods
- 100% dry after washing
- Heats from the inside and out for high quality reliable results
- Low maintenance, >20,000 operating hours per lamp
- 98% energy reflection with IRT 24K gold coated reflectors
- Melts the powder before entering hot air oven, no contamination
- Additional primer units are possible with compact heating
- Energy efficient; fully activated in <0.8 s. and instant shut-down



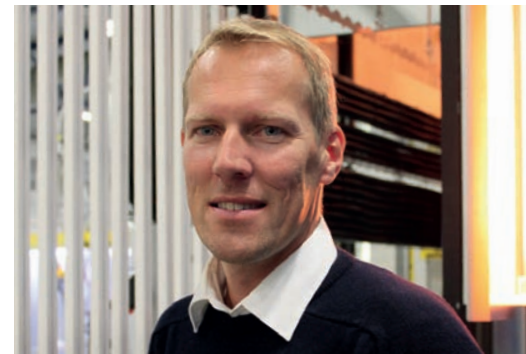
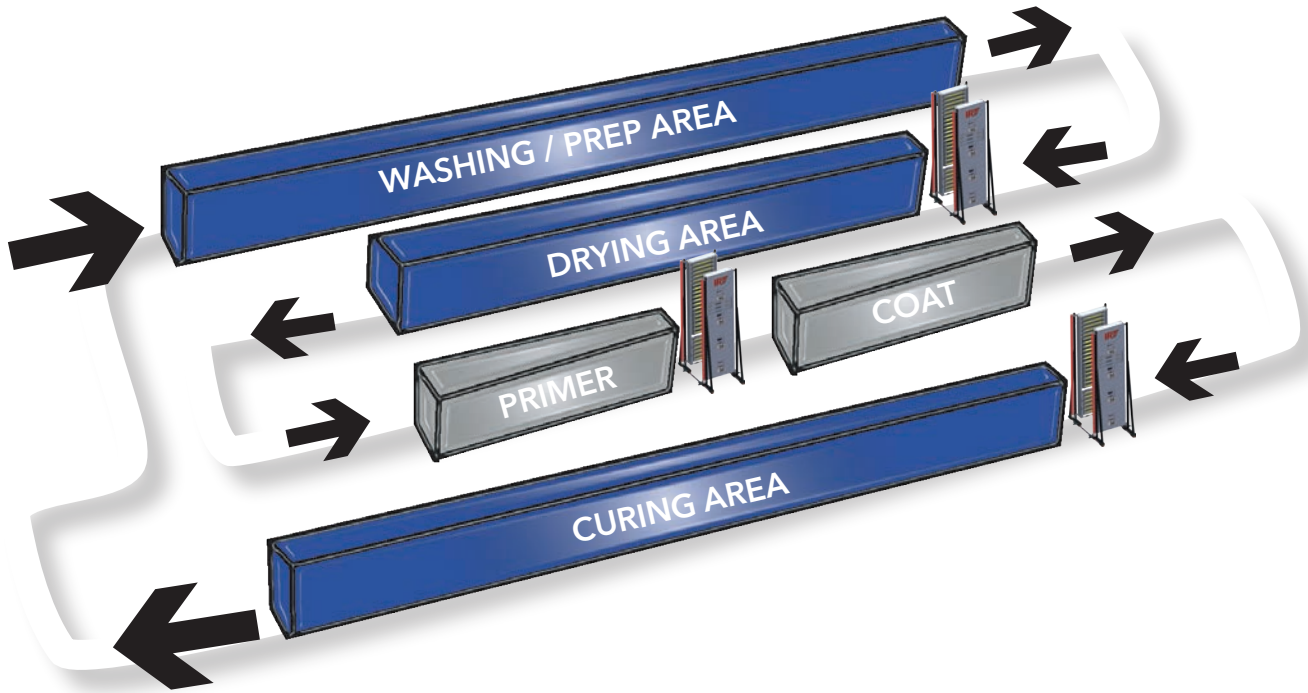

**QUALITY ISSUES DISAPPEARED** Lifting equipment manufacturer TAWI: "The IRT-Booster immediately turned up our production rate 20% and some quality issues disappeared."  
**TRIPLED PRODUCTION RATE** During a one year period Morsø outdoor oven manufacturer managed to triple the production rate. "IRT's test equipment worked so well that we simply refused to return it."  
**COMPLETE PROCESS CONTROL** Interior design industry PG & WIP with annual production of +22 million parts: "We use IRT solutions on all our production lines. Control of curing and production flow is essential with a fully automated process."



# IRT SINGLEHEATER

## IRT modular system

With IRT SingleHeater, we build simple, high precision effective and compact heat emitters with low power consumption, straight into the existing production line because a little space is required. This opens up great opportunities in getting the right kind of heat in the right place with tricky materials such as paper, plastics, metals, wood, paint and adhesives.

The IRT SingleHeater reacts extremely quickly to heating power regulation. The operational economy is excellent since IRT SingleHeaters are switched on and off based on specific production requirements.

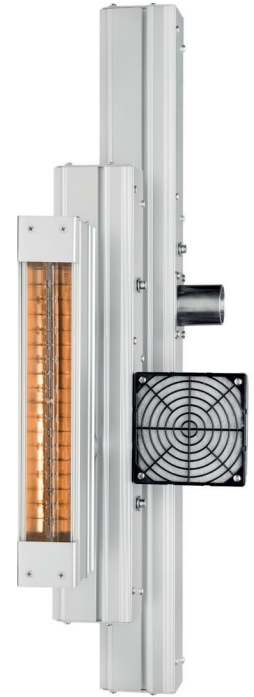

Model	Power	Dimensions (mm)	Voltage
LE/LP 117	0.2 kW	120x92x74	230 V
LE/LP 117	0.2 kW	120x92x74	230 V
LE/LP 230	0.5 kW	233x92x74	230 V
LE/LP 230	1 kW	233x92x74	230 V
LE/LP 360	1 kW	363x92x74	230 V
LE/LP 360	2 kW	363x92x74	230 V
LE/LP 360	3 kW	363x92x74	230 V
LE/LP 360	4 kW	363x92x74	230 V
LE/LP 500	2 kW	503x92x74	400 V
LE/LP 500	3 kW	503x92x74	400 V
LE/LP 790	3 kW	793x92x74	400 V
LE/LP 790	4 kW	793x92x74	400 V
LE/LP 1124	4 kW	1127x92x74	400 V

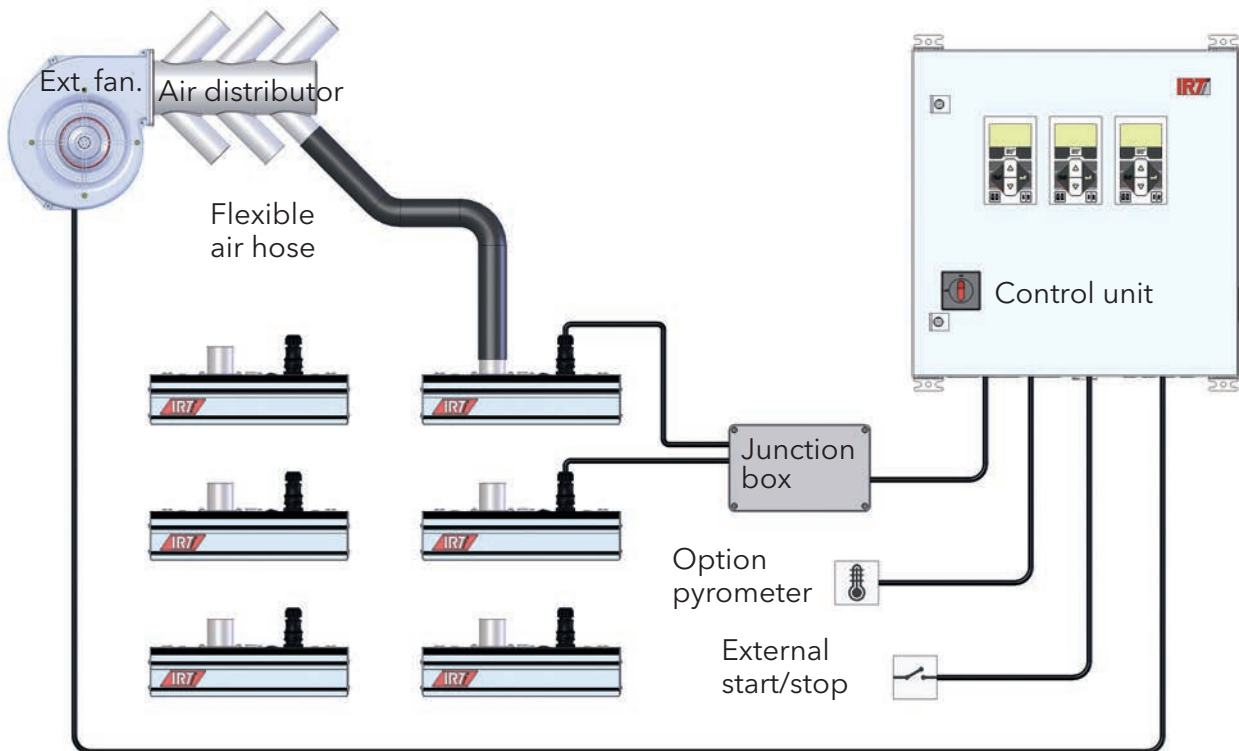

**EXAMPLE SET-UP:**

IRT SingleHeaters with external fan, control unit and pyrometer.



# OPTIONS AND ADD-ONS

## Options and add-ons create a flexible modular system

Contact us for assistance. We will make sure you get the exact result you need, in shortest possible time and saving energy in the process.

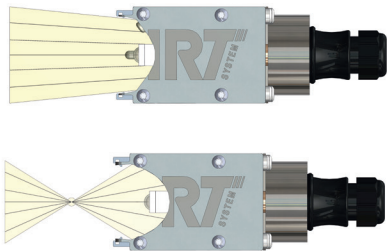

### REFLECTORS

Top: Parabolic / Bottom: Elliptic The IRT SingleHeater secret; direct and reflected radiation on the material.



### VENTILATION

Cooling can be performed with integrated, built-in fan or external fan.

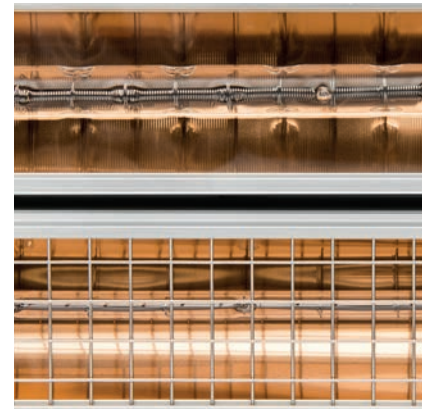

### PROTECTION

Safety glass or mesh in front of the lamp.



### ADD-ON: CONTROL UNIT

Control the object surface temperature in complex thermal cycles with easy-to-use, touch-screen panels. Connect to process start/stop.



### ADD-ON: AUTOMATIC START/STOP

Photo-electric cell detects production line activity.



### ADD-ON: TEMPERATURE CONTROL

Pyrometer for automatic surface temperature control.

## Fast, effective and energy efficient heating for all production lines

IRT SingleHeater consists of reflector body, replacable reflector strip with a surface coating of pure gold (reflects >98% of IR-radiation) and tubular IR-lamp of clear quartz (extremely high transmission capacity of IR-radiation).

Available in modular lengths and customized up to 6 m long, ready to install and connect.

MODULAR CHOICES FOR SINGLEHEATER	
Size	117 - 1124 mm
Power	0.2 - 4 kW
Voltage	115 - 480 V
Reflector profile	Elliptic (E) or Parabolic (P)
Lamp protection	Glass (G) or Net (N)
Ventilation	Integrated (I) or External fan (E), external fan is ordered separately

# PROJECT EXAMPLES

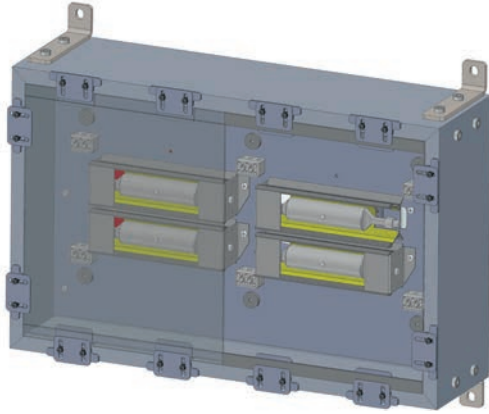

## UV DRYER

#312130	
<b>Application</b>	Door manufacturer production line
<b>Installation</b>	One unit on each side of the production line after edge treatment application. The UV-units cure the edge surface coating material
<b>Size</b>	600 x 400 mm
<b>Power</b>	16 kW

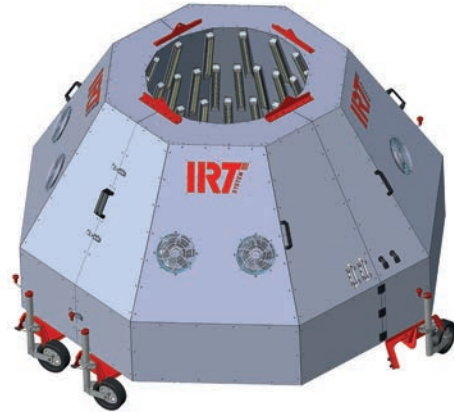

## HEAT EXPANSION IN AEROSPACE INDUSTRY

#302070	
<b>Application</b>	An IR-oven with infrared heat to expand parts onto fixtures. Pre-set to run 6 minutes and cool down for 3 minutes with password protected, adjustable settings. When the part has expanded into the correct position, it is fixed
<b>Installation</b>	Mobile with hinged opening, 3 PowerCassettes inside
<b>Size</b>	Appr 2 m high, 3 m diameter
<b>Power</b>	3 zones of 75 reflectors, total 285 kW

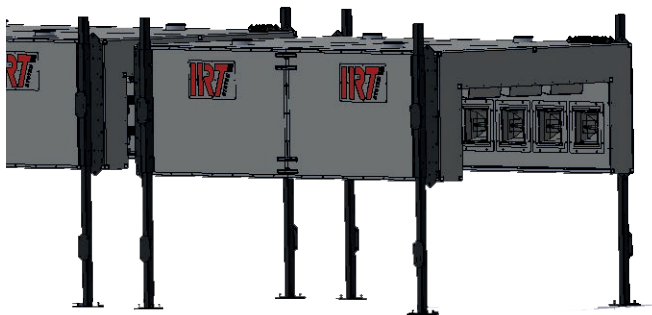

## IR/UV DRYER

#302080	
<b>Application</b>	Wet paint on plastic parts for the automotive industry
<b>Installation</b>	Two ovens installed in the production line. Parts are pre-heated with IR. A UV clear coat is applied to create a smooth surface for vacuum chromating. The UV-oven cures the clear coat in appr 2 min
<b>Size</b>	IR-oven 2980 x 1924 x 1900 mm UV-oven 3500 x 1924 x 1900 mm
<b>Power</b>	IR: 21 cassettes, 4 kW/pc UV: 40 cassettes, 2 kW/pc

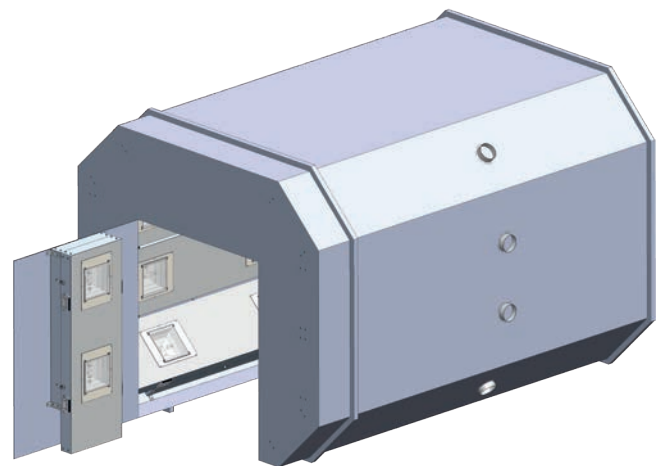

## UV CURING CABIN

#428-2015	
<b>Application</b>	Curing of UVB/UVC material
<b>Installation</b>	Cabin / tunnel
<b>Size</b>	Dimensioned for goods size 2400 x 1000 x 500 mm
<b>Power</b>	28 kW





## RAILWAY TRACKS

### #300080

<b>Application</b>	Curing of insulation glue between joints on railway track parts
<b>Installation</b>	10 SingleHeaters in arch layout over production line
<b>Size</b>	1100 × 500 × 300 mm
<b>Power</b>	20 kW

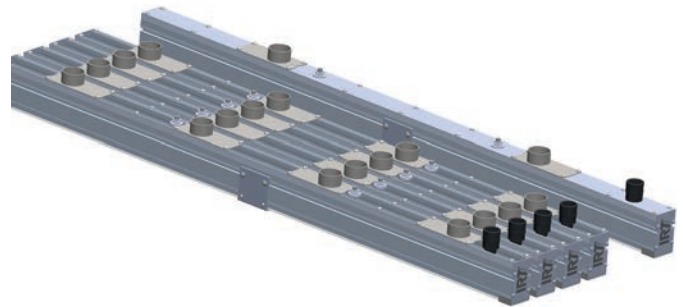

## SINGLEHEATER RAMPS

### #300990

<b>Application</b>	Heating cylinders in a laminating process in the paper industry. Keeps cylinder at constant temperature to enhance the laminating process
<b>Installation</b>	IR-heat added in 2 positions, to cylinder and to line: Cylinder: 4 x P 360, 4 kW/pc, 4 pcs/SingleHeater Line: 1 x P 230, 0.5 kW/pc, 6 pcs/SingleHeater Installed above production line, 2 suspensions/SingleHeater
<b>Size</b>	1444 × 55 × 110 mm
<b>Power</b>	Cylinder: 64 kW, Line 3 kW

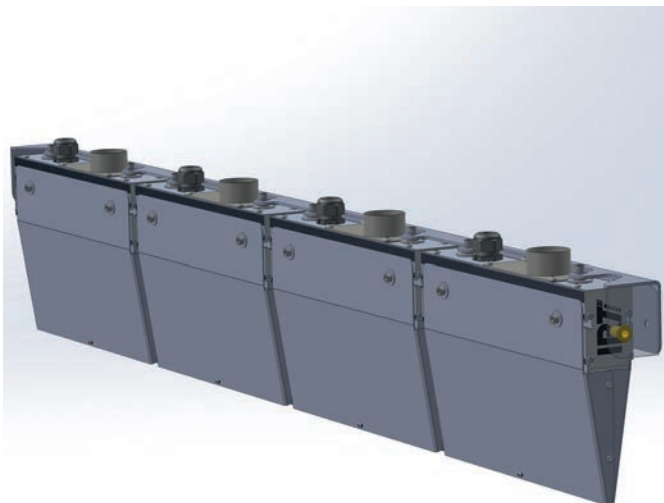

## EDGE DRYER

### #300860

<b>Application</b>	Laminated floor manufacturing process, surface treatment on edges of each floor module is dried with IR-technique.
<b>Installation</b>	2+2 SingleHeater 360 mm, with control unit 2 zones, 15 adjustable programmes Top 2 with mesh protection and bottom 2 with glass
<b>Size</b>	411 × 312 × 247 mm
<b>Power</b>	16 kW

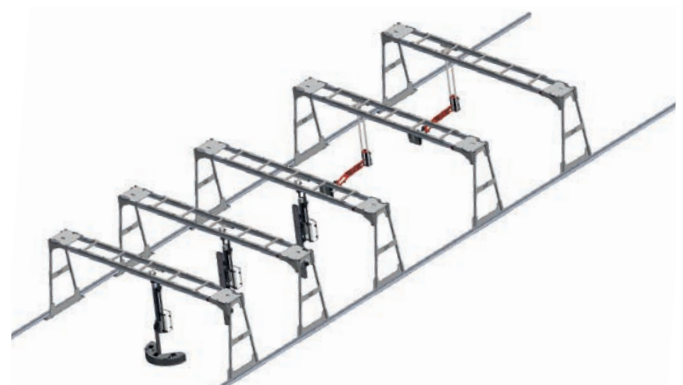

## CURING AVIATION PARTS

### #302020

<b>Application</b>	Heating glue in the aviation industry. Thermal sensors monitor, alert and react to overheating and other deviations from the set process. Curing analyzers register the process, second by second and report in easy-to-use graphs. All info is logged and exported via bluetooth to a post data analyzing tool for report purposes.
<b>Installation</b>	Three different types of IR shortwave dryers are installed in five crossbars. The rail system gives full accessibility to the assembly cells. The vertical motion is motorized to reach different heights.
<b>Size</b>	Rail system 22000 x 7000 mm

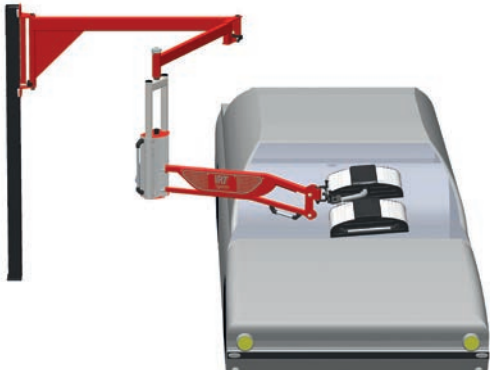

### SWINGARM DRYER

#6391	
<b>Application</b>	Automotive industry, off-line spot repairs
<b>Installation</b>	Fixed floor installation with knuckle jib and IRT dryer. The articulated swing arm spans easily around the car, with very little dead space. The arm is built in two sections, with the IRT dryer attached in the outer pivot point.
<b>Power</b>	See info on PcAuto and DTP dryers

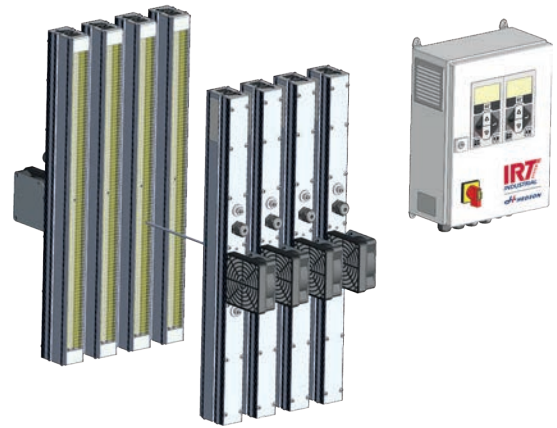

### AUTO B-COLUMNS

#301000	
<b>Application</b>	Heating B-columns online in automotive assembly
<b>Installation</b>	Fixed on each side of assembly line
<b>Power</b>	4 x 3 kW in two zones, for two B-columns



### O-SYSTEM DRYERS

#302380	
<b>Application</b>	Automotive industry
<b>Installation</b>	O-system rail installation for easy access to dryers, off-line spot repair spray booth area. Dryers equipped with add-on ergonomic, motorized arm. For improved working environment a Herkules Lift HM 1100-04 is flush-mounted in the floor
<b>Power</b>	2 pcs DTP 464-20 dryers, 20 kW/pc

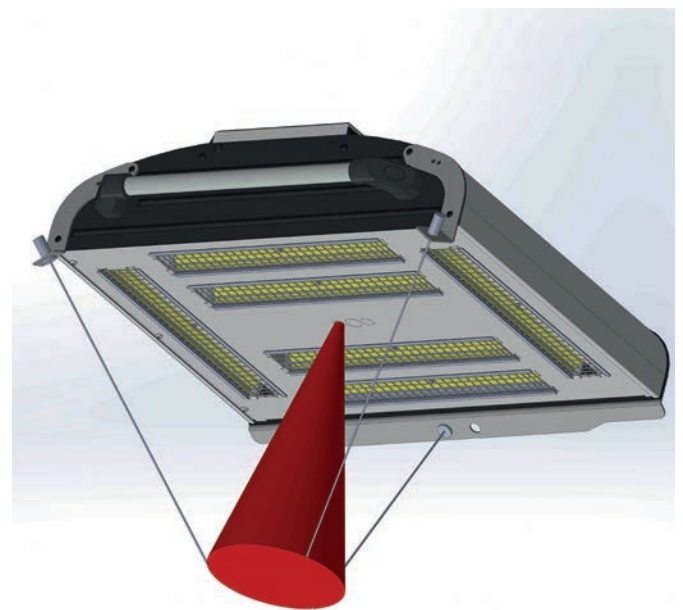

### 3-POINT LASER ADD-ON

#302090	
<b>Application</b>	Extra visual guide for correct distance and angle
<b>Installation</b>	Add-on for mobile units
<b>Size</b>	Cassette size 600 x 600 mm
<b>Power</b>	6 kW



### CURING IN AUTOMOTIVE ASSEMBLY LINE

**#399002**

<b>Application</b>	Customized high performance dryer DTP 425-2 equipped with a double pyrometer option to allow for easier adjustment. With a master pyrometer option on both cassettes you can reach even the most awkward positions on the car. Another add-on is the possibility to restart the laser to make sure the mobile is still in correct position in case of disturbances.
<b>Installation</b>	Mobile
<b>Size</b>	Cassette size 500 x 600 mm
<b>Power</b>	8 kW



### IRT POWERCASSETTE

**#33930**

<b>Application</b>	Conveyor line with IRT PowerCassettes to dry paint on composites in the aviation industry
<b>Installation</b>	PowerCassette modules on each side of conveyor
<b>Size</b>	4200 x 3800 mm
<b>Power</b>	270 kW



### CONVEYOR WITH IRT POWERCASSETTE

**#20220**

<b>Application</b>	Manufacturer of instrumentation and analyzer technology. Coil coating application on conveyor belt
<b>Installation</b>	Complete installation including pre-cooling zone, IR-drying zone, cooling zone
<b>Size</b>	6740 x 1265 x 510 mm
<b>Power</b>	24 kW

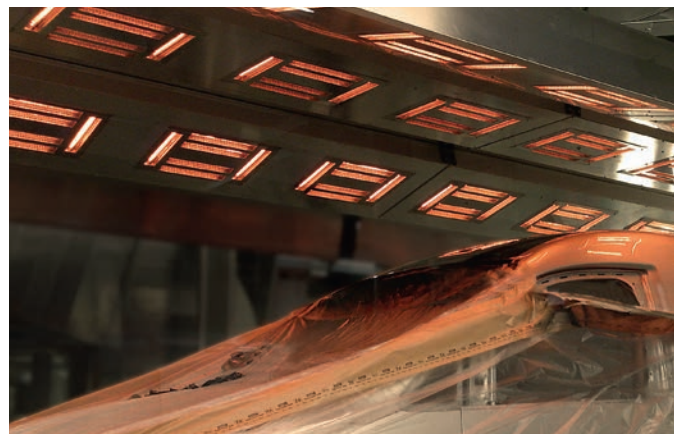

### ROOF HEATER

**#300180**

<b>Application</b>	Automotive assembly line, curing of paint on automotive ceilings
<b>Installation</b>	Roof heater for automotive assembly line
<b>Size</b>	6000 x 2000 mm
<b>Power</b>	240 kW





## MOBILE IRT-BOOSTER

**#300820**

<b>Application</b>	Outdoor oven manufacturing. Batches of cast iron parts cured with IRT-Booster. IRT's short-wave infratechnique replace traditional drying. Instant start-up and shut-off plus reduced running time and increased speed resulted in tripled production rate.
<b>Installation</b>	Mobile with SingleHeaters
<b>Size</b>	2504 × 1383 × 1969 mm
<b>Power</b>	80 kW

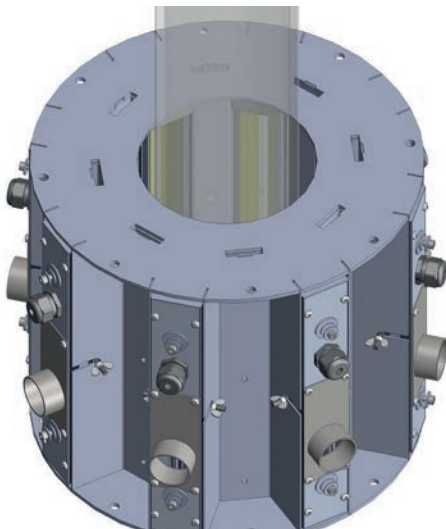

## TUBE CROSSLINKING

**#300690**

<b>Application</b>	Plastic tubing is crosslinked using infrared heat. The plastic fibre is interlaced to reinforce the material
<b>Installation</b>	IR-heater installed around tube
<b>Size</b>	Two models for two tube production units; 4 x 4 kW SingleHeaters for pipes $\varnothing > 75$ mm 8 x 4 kW SingleHeaters for pipes $\varnothing 75-160$ mm
<b>Power</b>	48 kW

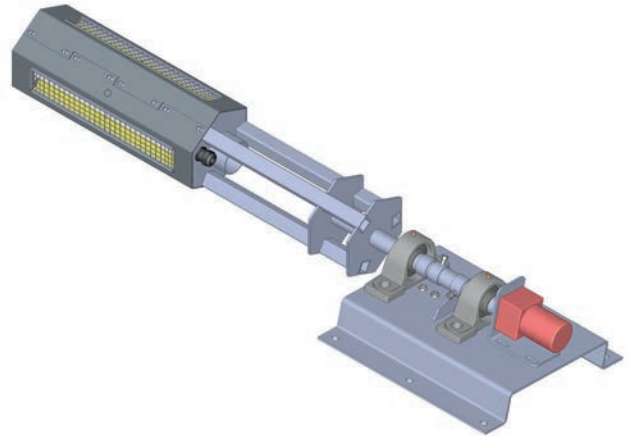

## INTERNAL PIPE CURING

**#300570**

<b>Application</b>	Pipes for energy industry
<b>Installation</b>	Rotating IR-heater to cure surface coating inside pipes
<b>Power</b>	48 kW



## TRUCK CABIN DRYER

**#300070**

<b>Application</b>	Automotive (truck) industry, off-line spot repair
<b>Installation</b>	Truck assembly, rail system dryer with motorized vertical motion
<b>Power</b>	PcAuto dryer 6 kW



## MULTIPLE LINE IRT OVEN FOR POWDER COATING

### #300840

<b>Application</b>	Parts manufacturer (interior decoration) with annual processing, powder coating and packaging of appr. 22 million parts. Curing parts of varying height 50-1500 mm
<b>Installation</b>	A complete IRT-System oven with several lines to maintain control of curing and production flow
<b>Power</b>	530 kW



## TELESCOPIC MOBILE

### #300400

<b>Application</b>	Automotive industry
<b>Installation</b>	Off-line spot repair inside vans
<b>Size</b>	Extended telescopic reach, 1000 mm
<b>Power</b>	6 kW



## U-SYSTEM RAIL DRYERS

### #300450

<b>Application</b>	Automotive industry, off-line spot repair
<b>Installation</b>	Rail system dryers in U-shaped rail system. Front dryer with motorized angling positioning
<b>Size</b>	Installation height 2500 x width 1200 mm
<b>Power</b>	68 kW

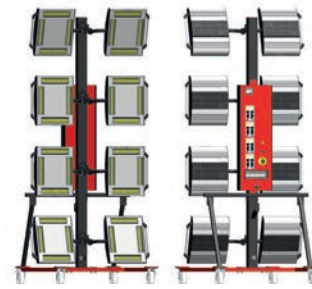

## LARGE-SCALE MOBILE

### #300780

<b>Application</b>	Large-scale mobile dryer suitable for all types of curing, heating and drying
<b>Installation</b>	Mobile, with 8 cassettes 4 kW/pc
<b>Size</b>	
<b>Power</b>	4-8 cassette mobile, 48 kW



## MOTORIZED ARM

### #302230

<b>Application</b>	Automotive industry
<b>Installation</b>	Rail system dryers with ergonomic, motorized arm function
<b>Power</b>	IRT DTP 428 12 kW and IRT DTP 425 8 kW



## IRT-BOOSTER

### #81 -2011-1

<b>Application</b>	Boosting the powder coating line in lifting equipment manufacturing
<b>Installation</b>	IRT-Booster installation in powder coating line turned up production rate almost 20%. Some quality issues also disappeared in the process
<b>Size</b>	500 x 280 x 300 mm
<b>Power</b>	18 kW

## PERFORMANCE ABOVE ALL

Hedson is a leading supplier of premium curing, lifting and cleaning systems for auto workshops and industry worldwide. We come from the land of engineering, and have decades of experience learning from and innovating to real customer needs – technologies that improve the working environment, protect workers and boost productivity. Our ambition to add real measurable values is obvious wherever Hedson solutions are seen, sold or working – from advanced yet easy to use equipment to unmatched customer service, Hedson stands for performance above all.

[www.hedson.com](http://www.hedson.com)

