

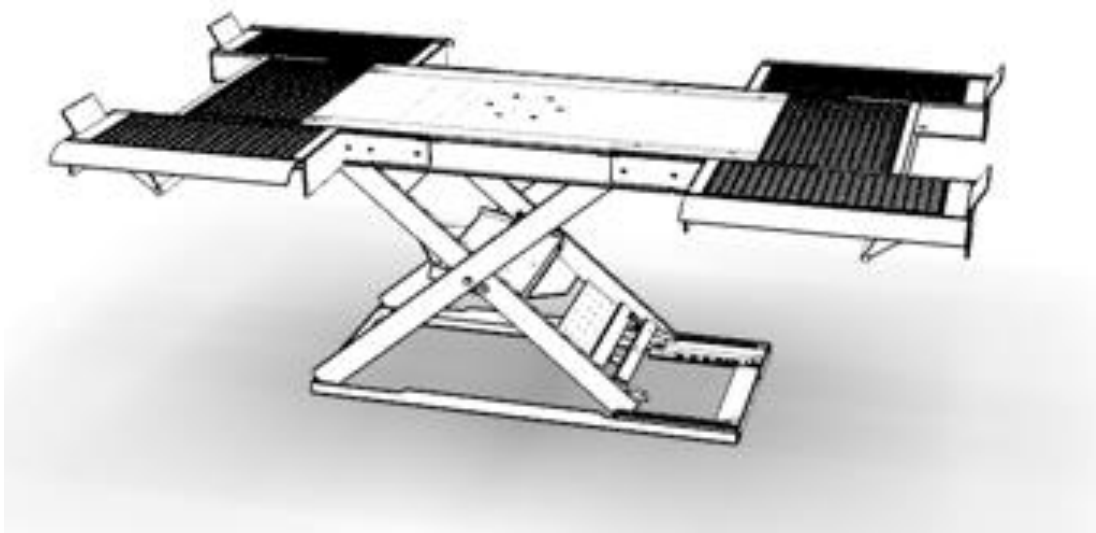

Operation Instruction and Inspection Log for Lifting Platforms

Machine type	Art. no.:	Manuf. no.:
K1600-HLS	HLS 1600-11	
K1600-HLS	HLS 1600-14	



Hedson Technologies AB
Hammarvägen 4
SE-232 37 Arlöv, Sweden
Phone: +46 40 53 42 00



760-062_K1600-HLS_2017.05_2.4_US
Translation of „760-062_HLS1600-11-14-16_2017.04_2.7_DE“

TABLE OF CONTENTS

Table of contents

1	Functional and safety checks.....	5
2	General information	6
2.1	Hazard information	6
2.2	Limitation of liability	6
2.3	Copyright	7
2.4	Guarantee terms	7
2.5	Customer service	7
3	Product description	8
3.1	Proper use.....	8
3.2	Structure.....	9
3.3	Technical data	10
3.4	Product identification	10
4	EC declaration of conformity.....	11
5	General safety information.....	12
5.1	Operator's duty of care.....	12
5.2	Duties of the operator.....	12
5.3	Fundamental safety measures	13
5.4	Requirements of operating personnel	14
6	Transport and preparation	15
6.1	Transport inspection.....	15
6.2	Prepare and align	15
6.3	Packaging and disposal	15
7	Installation and assembly.....	16
7.1	Environmental requirements for installing the equipment.....	16
7.2	Installation and assembly	17
7.3	Installation surface or pit	17
7.4	Mounting of the HLS wheel stands.....	19
7.5	Electrical grounding, electrostatic charging	22
8	Operation	23
8.1	Description of the operating elements.....	23
8.2	Working at the lifted vehicle	24
8.3	Commissioning.....	24
8.4	Operate	24
8.5	End of work	27
9	Troubleshooting	28
9.1	Possible problems and their resolution.....	28
10	Maintenance	29

10.1	Air bags characteristics and durability	30
10.2	Notice about filter regulator and air line.....	30
10.3	Notice about the sliding area of the scissors	30
10.4	Inspection points, checkpoints and lubrication service points	31
11	Safety checks.....	33
11.1	Regular safety checks	34
12	Additional information	35

FUNCTIONAL AND SAFETY CHECKS

1 Functional and safety checks

Carried out by the manufacturer to the following specifications:

Don't remove the labels attached on the lift and keep them always readable.

Labels attached:

- Type plate
- Operating instructions (short form)
- Loading capacity
- Mains pressure
- Lifting-UP, Lowering-DOWN
- Company logo
- CE marking

Function und safety tested:

- Safety valve set to 50.76 psi (3.5 bar) operating pressure**

Tested:

- Functional test without load
- Anti-drop safety function
- Operating valve goes automatically to 0 setting
- No damage on the surface of the airbag
- All bearing screws are firmly seated
- Scissor bolts secure
- Conditions of pneumatic lines (seated firmly and seek proof)
- Function of drive-on ramp
- Function roll-off safety device
- Function center deck

Manuf. no.: see cover sheet

Date: _____

Name: _____

Hedson Technologies AB
Hammarvägen 4
SE-232 37 Arlöv, Sweden
Phone: +46 40 53 42 00

2 General information

The operation instructions and inspection log contain important information regarding the installation, safe, appropriate and efficient operation and maintaining functional safety. Their observation helps to avoid risks, reduce repair costs and times of failure and prolong the durability of the lifting platform.

Function- and safety checks (manufacturer)

Regular safety checks (customer)

This inspection log book contains a log sheet to act as evidence that regular safety checks have been carried out. You should use this log sheet to make a record of inspections made. (We recommend you to duplicate the form before the first fill in).

Assembly and inspection

Only trained personnel are allowed to carry out safety work and safety inspections. As a general rule, such persons are described in this manual as authorized inspectors or technical specialists.

2.1 Hazard information

The following symbols are used to indicate danger points and to highlight important information. An explanation of their meanings is given. Please pay particular attention to areas of the text containing a symbol of this nature.



This describes a hazard to life or the danger of severe injury. There is a severe hazard of mortal injury if the procedure described is not carried out correctly!



This indicates a key function or an important note!

2.2 Limitation of liability

All the information and notes of this operating instruction have been compiled in consideration to prevailing rules and directives, the actual state of technique and our long standing experience. The manufacturer assumes no liability for any damage caused by:

- Non-compliance of operating instruction
- Use not intended by the manufacturer
- Assignment of non-authorized personnel
- Unauthorized modifications
- Disregard of maintenance intervals

2.3 Copyright

The operating instructions have to be used confidentially and only by trained personnel. It is not allowed to forward the operating instructions to third parties without written approval by manufacturer



All written materials, drawings, pictures and additional illustrations are copyrighted and subject to commercial property rights.

2.4 Guarantee terms

The guarantee regulations can be found in the sales documents as a separate file.

2.5 Customer service

For any further technical information, please contact our Customer Services:

Customer service:	Hedson Technologies AB Hammarvägen 4 SE-232 37 Arlöv, Sweden Phone: +46 40 53 42 00
----------------------	--

3 Product description

3.1 Proper use

The lifting platform for vehicles HLS 1600-11 and HLS 1600-14 serves exclusively for the lifting of vehicles with a total weight according to the technical data. Lifting is allowed exclusively by vehicle standing on the wheels or at the framework.

You may not raise persons or other objects.

Any work underneath the lifted vehicle during lifting and descending is not allowed.

Only persons having read and understood the operating instructions are allowed to use the lifting platform. Furthermore, they have to be at least 18 years old.

Vehicles may only be lifted at the designed lifting points (at framework or on the wheels). It is only allowed to lift vehicles as stated in the operating instructions.

Using the device properly includes reading the instruction manual - in particular the safety instruction.

Furthermore, all inspection and maintenance work should be carried out at the prescribed intervals

If the vehicle-lifting platform is not used in accordance to these instructions, safe operation of the platforms cannot be guaranteed.

Any other or additional use of the lift is considered to be improper.

The manufacturer is not responsible for any personal injuries or material damage to vehicles as a result of improper use of the lifting platform!

PRODUCT DESCRIPTION

3.2 Structure

The HLS 1600 vehicle lifting platforms consist of a lower frame, an upper frame with telescoping extensions, folding centre decks, two scissors, a 3-compartment air bag, anti-drop safety function and a control panel. Two hoses (16 and 6 mm) lead to the compressed air connection.

The air bag implements the lifting movement, which is executed laterally by means of the scissor-type stays. The scissor-type stays also limit the platform's lifting height. An anti-drop safety device prevents the lifting platform from subsiding in the event of air loss.

The vehicle is lifted up completely by means of the telescoping extensions and/or the support arms.

The lifting platform is operated from a control panel, connected to the lifting platform by means of a hose-type hose. For further information see chapter "**Operation**".

Neither electric nor hydraulic power is necessary to operate the vehicle lifting platform. It is operated solely by means of compressed air.

For further information about the HLS 1600 vehicle lifting platform please see chapter "**Technical data**".

Information regarding the structure see chapter "**Installation and assembly**".

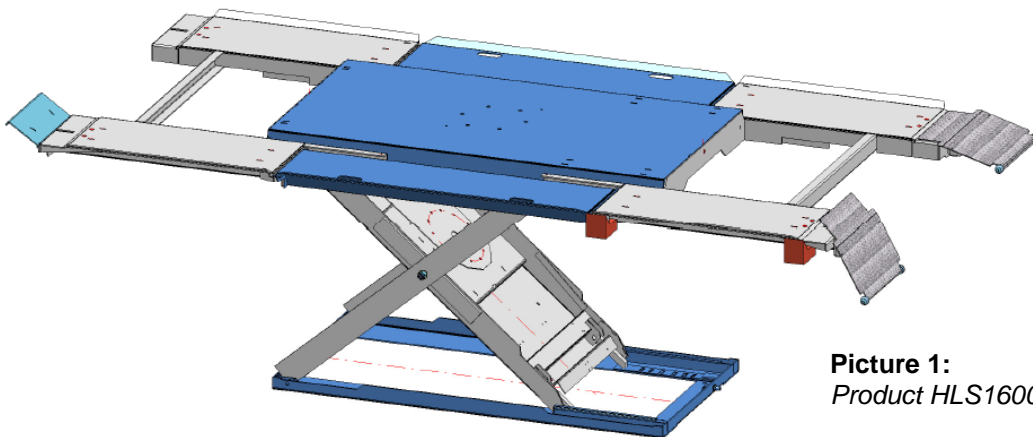

Picture 1:
Product HLS1600-11

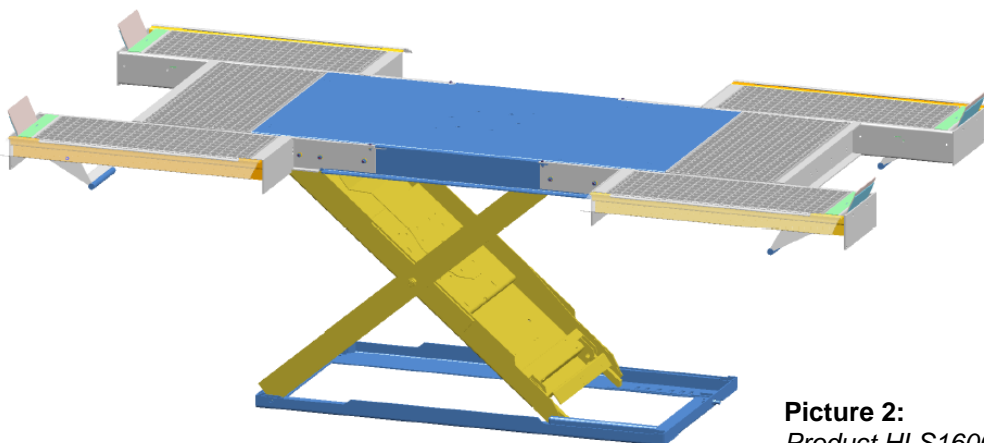

Picture 2:
Product HLS1600-14

3.3 Technical data

<i>Subject to technical changes.</i>	HLS 1600-11	HLS 1600-14
Carrying capacity of the lift	6613 lb (3000 kg)	6613 lb (3000 kg)
Max. Load distribution	3:2 in- or against the driving-on direction	
Lifting time of the platform	25 sec.	
Lowering time of the platform	30 sec.	
Nominal lift of platform	42.28" (1150 mm)	42.28" (1150 mm)
Max. overall height	51.18" (1300 mm)	42.28" (1150 mm)
Min. construction height/ Drive-over height	5.9" + 0.4" (150+10 mm)	none
Length of lift body	78.35" (1990 mm)	
Width of lift body	44.49" (1130 mm)	
Length platform	174.8" (4440 mm)	161.42" (4100 mm)
Width platform	80.31" (2040 mm)	78.15" (1985 mm)
Drive	Pneumatically (3 airbags)	
Operating pressure for safety valve	50.76 psi (3,5 bar)	
Pneumatic mains connection P _{max}	116 psi (8 bar) (supplied by the customer)	
Noise load below	< 70 dB(A)	
Dimension sheet	K 1615-HLS-002-3	K 1615-HLS-004-3
Installation drawing		K 1607-HLS-003-3 Sheet 1+2
Fitting frame for concrete		K 1607-HLS-127-3
Fitting frame for grid		K 1607-HLS-128-3
Pneumatic circuit diagram	K 1607-HLS-008-3	K 1607-HLS-008-3
Parts list pneumatic	K 1607-HLS-008-3	K 1607-HLS-008-3
Parts list platform	K 1607-HLS-004-3	K 1607-HLS-002-3
Safety devices		
Anti-drop safety device platform	Yes	Yes
Safety valve	Yes	Yes
Anti-roll-off safety device for vehicle	Yes	Yes
Mechanical safety device	No	Protection frame
Pneumatic safety device	No	No
CE-Stop with acoustical warning		

3.4 Product identification

The identification of the lifting platform can be found on the type label on the frame of the lift as well as in the Declaration of Conformity.

Indications on the type label

Article no.		Year of construction	
Machine type		Operating pressure	
Serial no.		Vers.	
Loading capacity		Net weight	

EC DECLARATION OF CONFORMITY

4 EC declaration of conformity

In accordance with Appendix II A of the EC Machinery Directive (2006/42/EG)

The manufacturer	Herkules Hebetchnik GmbH Falderbaumstraße 34 34123 Kassel			
Responsible for documentation	Herkules Hebetchnik GmbH			
Hereby states that the machine described below	Lifting Platform	Machine- Type	Article- No.	Series- No.
		HLS-1600-11	HLS 1600-11
		HLS-1600-14	HLS 1600-14
Complies with the following EC Directive:	EC Machinery Directive 2006/42/EG			

Applicable harmonized standards:

EN 1493 EN ISO 12100-1/2	Vehicle lifting platforms Safety of machinery
-----------------------------	--

EC type examination	No. of inspection certificate
K1600-HLS-11	44 205 12 021011
K1600-HLS-14	44 205 12 021011
Testing centre	TÜV Nord Cert GmbH

Kassel, 17.01.2017

Place, Date



Dirk Meinzer, Managing Director

5 General safety information

5.1 Operator's duty of care

The vehicle lifting platforms described in these operating instructions have been designed and built to comply with the results of a hazard analysis, carefully selected harmonised standards and other technical specifications to which the device must comply. The lifts therefore correspond to the latest state of technology and ensure the maximum level of safety.

This level of safety can only be achieved in operational practice if all the necessary measures have been taken. It is the diligence of the operator of the lifting platform to plan these measures and control their execution.

In particular, the operator must ensure the following:

- That the lifting platform is used only for the intended purpose see chapter **“Product Description”**.
- That the lifting platform is operated always in perfect and properly functioning condition, and that in particular the safety devices are regularly checked for correct function.
- That the place of the control of the lifting platform is designed so that the operator has full visibility on the lifting platform and the load in all movements and that the operator can overlook the space under the lifting platform and the load. With poor visibility, the operator must ensure for an adequate lighting.
- That it will be prevented the access to persons in the area of risk (area under the lifting platform and the load). The work in the area of danger is prohibited. Apart from the maintenance work, see chapter **“Maintenance”**
- That the operating instructions are kept in a legible condition, and that they are available, complete, at the location where the lifting platforms are deployed.
- Those only persons are allowed to use and operate the lifting platform having read the operating instructions.
- That these persons receive regular instruction in all matters concerning safety work and environmental protection, and that they are fully aware of the operating instructions, and in particular, the safety information contained therein.
- That only sufficiently qualified and authorized person are allowed to repair the lifting platform.
- That the safety and warning notices attached to the lifting platform will be not removed, and that they remain readable at all times.
- That after the use the lifting platform is lowered and the operation is secured against misuse by padlock (by customer).

5.2 Duties of the operator

The regulations of industrial safety provide some measures for the operator of work equipment for use in hazardous areas.

The operator must carry out a risk assessment of the area in which the working equipment (lift) is to be used. The hazards, which can be caused when using the working equipment in conjunction with the agents and the work environment, should be recognized and taken into account.

The operator shall take the necessary measures and he selects the one resource which is suitable for the conditions in the workplace and for which safety and health protection are guaranteed when its use is intended.

To carry out the risk assessment and the selection of appropriate resources the operator must apply national directives and standards.

5.3 Fundamental safety measures



When operating the lifting platform, the prevention against legal accidents in accordance with BGV A 1 (General Provisions, German law) must be obeyed. For informational purposes please refer to the regulation BGR 500 (operation of equipment, German law).



Make sure that the front wheels are straightened out position. Before lifting, ensure the vehicle against rolling. Pull the handbrake and put the transmission in reverse or first gear. Vehicles with automatic transmission put gear selector in “park”.



The operator must always carefully observe the car during the lifting or lowering process.



The lift and its parts such as air cushion or air bag need to be protected from heat damage at all times. Damage can occur from welding, sanding or any other process involving high heat.

We draw your attention in particular to the following regulations:

- Follow the operating instructions during the operating of the lifting platform.
- The lifting platform must be used only to lift motor passenger cars
- The total weight of the lifted vehicle must not exceed the maximum load capacity, with a maximum permitted load distribution of 3:2 in or 2:3 against the drive-on direction.
- Only employees who are over the age of 18 and who have received full instruction in operating the lifting platform are authorised to use the lifting platform without supervision.
- Apart from the operator, no person is allowed to be within the working area of the lifting platform during the lifting or lowering process.
- No person may be carried either on the lifting platform or inside the vehicle.
- Climbing onto the lifting platform or onto the lifted vehicle is prohibited.
- The rubber blocks have to be placed onto the biggest plain space. Stacking is not allowed.
- Before the vehicle is driven onto the lifting platform, always ensure that there is sufficient space between low-lying parts of the vehicle and the lifting platform.
- Do not make interventions on the lifting platform before maximum lift (no load) is reached and is supported by the supports.



Ignoring the safety regulations can result in hard personal injury and damage on the lifted vehicle.

5.4 Requirements of operating personnel

The lifting platform must be operated only by persons who are trained, instructed in its use, and authorised to do so. Such persons must be well aware of the operating instructions and must act accordingly. The various levels of authority of operating personnel must be set out clearly.

In addition, special qualifications are required to carry out the following activities:

Activity	Realization
Assembly	Hedson Customer service technician / trained person
Start-up	Hedson Customer service technician / trained person
Instruction	Hedson Customer service technician / trained person
Fault clearance	Hedson Customer service technician / trained person
Maintenance	Hedson Customer service technician / trained person
Servicing	Hedson Customer service technician / trained person
Repair	Hedson Customer service technician
Disassembly	Hedson Customer service technician / trained person

Apprentices are allowed to work at the lifting platform only when supervised by an experienced person. Written confirmation must be provided that the machine induction process has been completed.

Only persons who have completed such induction may operate the control and safety devices.

All persons carrying out any activities on the lifting platform must read the operating manual and confirm, by means of a signature, that they have understood the operating instructions.

6 Transport and preparation

Be cautious when bringing the pallet with the lifting platform and the telescoping arms to the installation site. Use suitable transportation device.



Loading capacity of suitable subsides > dead weight of lift (see technical data).

6.1 Transport inspection

Check the lift after receipt of the shipment for completeness and shipping damage. In Case of apparent damage, proceed as follows:

- Let the goods and the packaging remain unchanged. Don't use the product.
- Contact immediately the customer service

Customer Service: Hedson Technologies AB
Hammarvägen 4
SE-232 37 Arlöv, Sweden
Phone: +46 40 53 42 00



Please return damaged goods only after having talked to Customer Services!

6.2 Prepare and align

Place the parts in that way that the air hoses show to the air supply. Remove the foil and transport lock. Couple the control panel (lever valve in accessories) with 16 and 6mm rubber hoses to the lifting platform. Use enclosed hose clamps.

Install the telescoping extensions to the ground symmetrically to the platform. Please see installation instruction and chapter "**Installation surface or pit**" of the manual.

Then lower the upper frame of the lift completely, position the lift and fix it to the concrete floor or the supporting construction, see chapter "**Prepare and align**".

6.3 Packaging and disposal

Remove the foil and transport lock. Dispose packaging material correct and environmentally fair. Do not burn up packaging materials.

7 Installation and assembly

For the installation of this product the following safety measures have to be observed strictly to prevent severe personal injuries, damage to the machine and other material damage.

- Only qualified persons, who follow the safety instructions, may carry out the installation work.
- Before starting assembly work, check the lifting platform for transport damage.
- Make sure that only authorized persons are in the working area, and that no other persons can be put at risk by the installation work.
- All machine connections (hoses) – must be laid in such a way that they cannot cause a stumbling hazard.
- Also read the chapter “**General Safety Information**”.

7.1 Environmental requirements for installing the equipment

The lifting platform is suitable only for dry indoor use.

The installation site of the lifting platform must be horizontal and flat (according to DIN 18202), furthermore the floor base on which the platform will be used has to be sufficiently strong to support the allowed maximum weight of the platform.

The operator of the lifting platform is responsible for the selection of the mounting place.

The lifting platform must be used only in a temperature range of 41°F to 149° (5°C to 65°C). Regard the dimensions of the platform specified in the chapters “**Technical data**” and “**Additional information**” when choosing the place for the installation (observe the dimensions with an elevated vehicle).

An adequate height of the ceiling must be provided (minimum total height of the lifting platform plus the height of the vehicle). Furthermore, in closed premises it is required to maintain sufficient minimum distance to the walls or other equipment, to escape routes, etc. (according to country-specific standards and workplace regulations) to ensure safe working. On the installation side sufficient lighting (according to country-specific standards and workplace regulations) must be provided.

When operating the platform the operator must have a clear view of the hazard area.

To use the lifting platform, at the place of installation there must be a connection to the compressed air for R1/2 with 116 psi (8 bar) pressure network. Connect the compressed air from the customer with the connection of the control unit.



Use only dry and non-oily compressed air! A filter control system must be provided on the main line (air filter and water separator)!

7.2 Installation and assembly

Bring the lift and the HLS wheel stands on the pallets with a suitable conveyor to the installation side. Place the parts on the ground that the air hoses point towards the air supply. Remove the plastic film and the transport securing devices. Dispose the packing material in an environmental friendly and professional way. Don't burn them!

Connect the control unit (hand valve lever packed with the accessories) to the 16 mm and 6 mm hoses and the platform. Use the supplied hose clamps and connection pieces. Clip the compressed air hose (supplied by the customer) with the coupling socket NW7 on the lever valve. Charge the platform on the pallet with air until the safety catch has slipped over the last tooth. Release the lever valve.

Bring the HLS wheel stands to the platform and assemble it, see chapter **“Electrical grounding and electrostatic charging”**.

After the assembling of the wheel stands, raise the platform with a suitable lifting device as much on the cross beam that the lower frame rests on the ground. Remove the pallet and lower down the platform. After that align and fix the lift, see chapter **“Installation surface or pit”**.

7.3 Installation surface or pit

The lift has to be placed on a flat ground or on a supporting construction with sufficient stability. The installation surface and the foundation have to be designed for maximal critical load, even in unfavorable operation conditions. When installing the lift on intermediate ceilings the permissible floor load has to be observed.

For the installing of the lift in a pit, (in-ground lift HLS1600-14) proceed according to the indications of the dimensional drawing and the installation plans of the manufacturer (see chapter **“Additional information”**).

Configure the protection frames as described below:

Remove the angle brackets off the end pieces of the frame. Put down all the pieces as shown on the drawing (see as well **“Additional information”**) and screw them with each other according to detail „X“. Protect the frame against sliding away when grouting. The dimensional accuracy of all internal dimensions has to be ensured

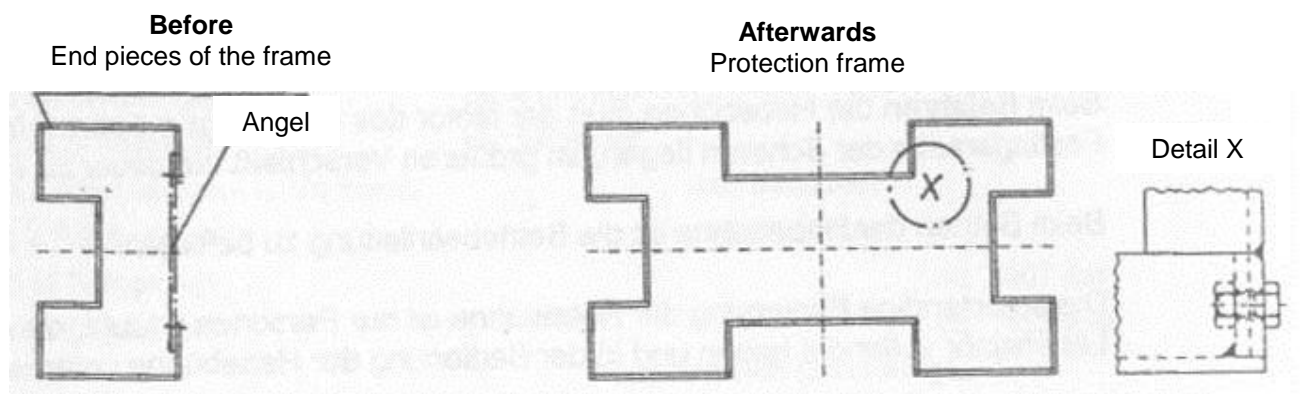

Pic. 3: Fitting protection frame

The place of installation has to be prepared according to the installation plan. Respect the correct driving direction. Connect the hand lever valve to the air hoses, \varnothing inside: 6 mm and 16 mm, at the front side with (see as well chapter **“Operation”**).

Fixation of the lift

HLS1600-11, HLS1600-14

Align the lift, drill out, sufficiently deep, 6 holes with a diameter of 16mm from the lower frame. Remove the dust then screw the lift with 12x100 screws, washers 13 and dowels S16 (accessories).

Bild 4: Fixation to the foundation

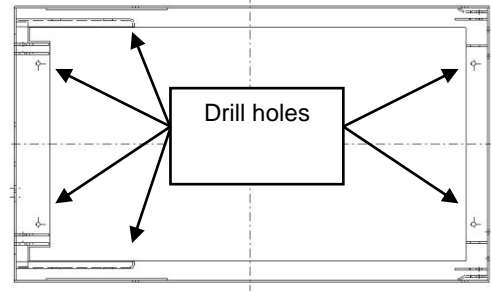

Fixation of the operating element

Assemble the operating element to the wall, a support or on the floor (foot valve) according to the locality. If necessary, cut the hoses. As needed, protect the hoses with bridging tracks (not included in the scope of delivery).



When choosing the place to locate the operating element, ensure that operators have a clear view of the lifting platform and of the vehicle being lifted or lowered.

Connect the air supply, supplied by the customer (**$P_{max} = 116 \text{ psi (8 bar)}$**) to the operating valve. A filter control system must be provided on the mains line (air filter and water trap).



Use only dry and non-oily air.

7.4 Mounting of the HLS wheel stands

The upper frame of the lift has longitudinally guide rails on both sides. From both front ends of the lift the HLS wheel stands are inserted in these rails and fixed with screws, washers and nuts.

HLS1600-14 (in-ground lift)

Fix the HLS wheel stands with screws, washers and nuts to the upper frame of the lift body. Insert all lateral screws from the side of the lift body and screw them with nuts from the outside. On the front side insert the screws from the side of the wheel stands (see pic. 5). Mounting material, see assembly diagram and parts list on page 30.

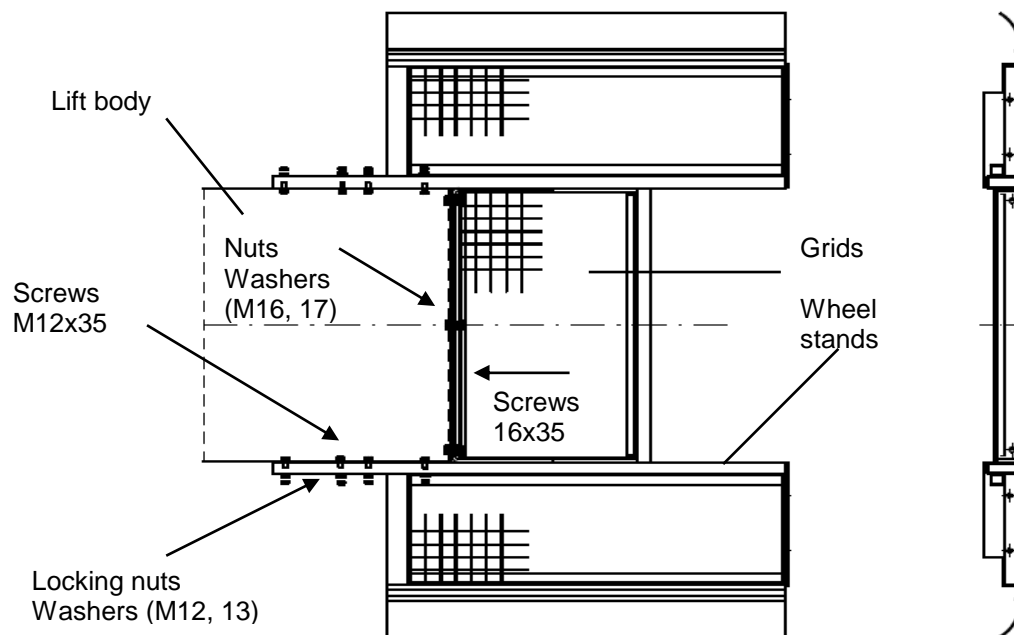

Pic. 5: *Mounting of the wheelstands*

Fix the roll-off protection (4x) with the fixing material packed with the accessories of the lift after having fastened the HLS wheel stands to the lift. Only then insert the grids.



Mounting of the roll-off protection for the protection of the vehicle against absolutely necessary.

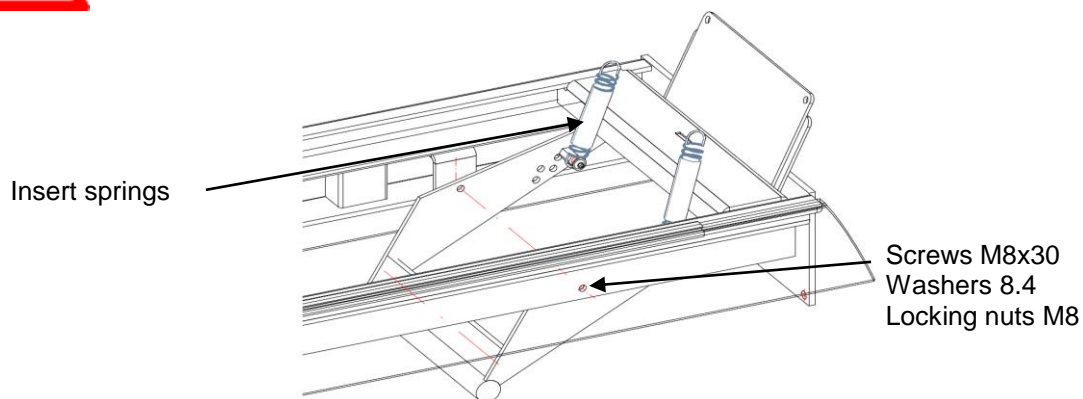

Pic. 6: *Mounting of the roll-off protection*

HLS 1600-11 on-ground
Wheel stand driving-on side

Fasten the wheel stands at the side of driving on the lift with screws, washers and nuts and connect the driving-on ramps to the supports after having fastened the supports with screws to the wheel stands. Fixing material see assembly diagrams (pic. 7, 8).

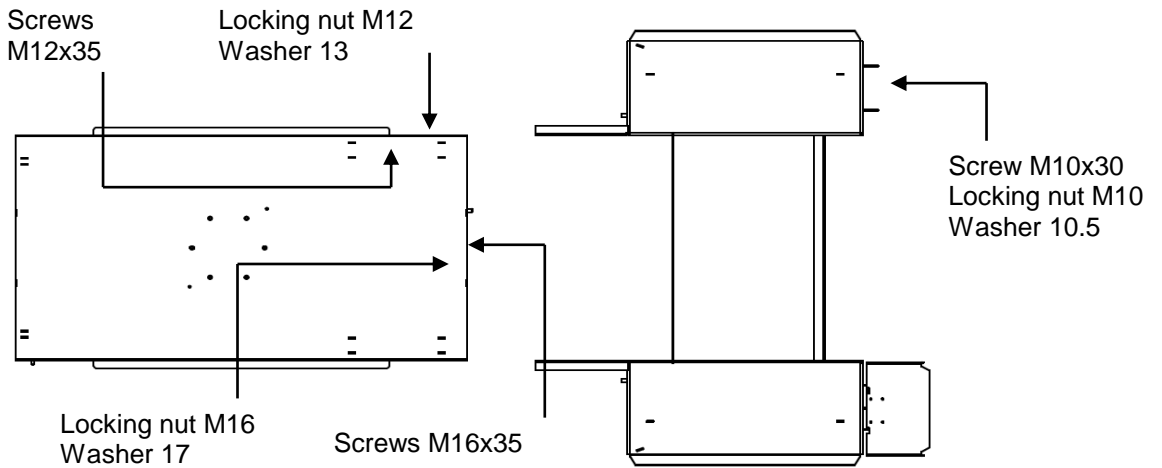

Pic. 7: *Mounting wheel stands drive on side*

Wheel stand with roll-off protection (side with stop)

Fasten the wheel stand at the side with the stop with screws, washers and nuts and fasten the roll-off protection to the wheel stand.

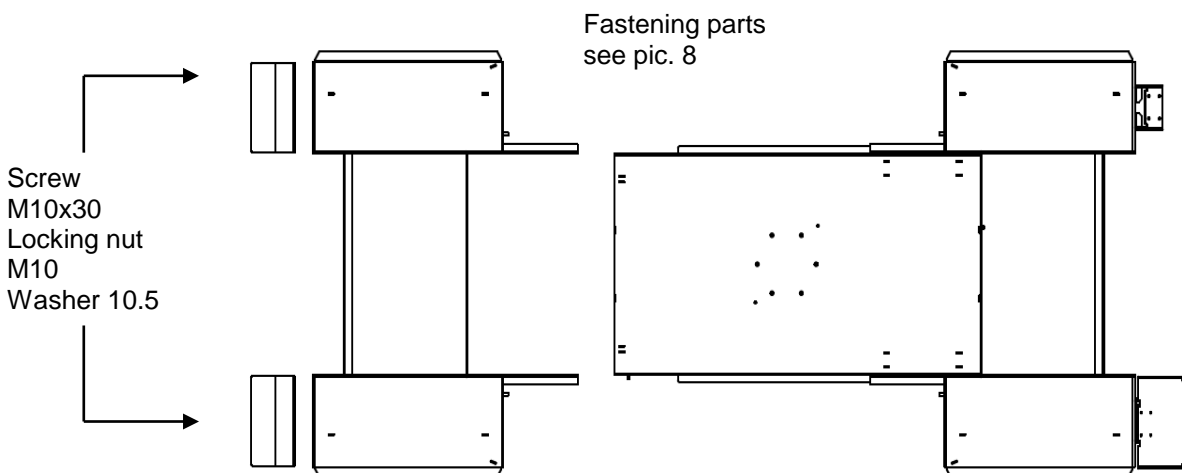

Pic. 8: *Mounting wheel stands side of stop*

INSTALLATION AND ASSEMBLY

Center decks

Hook the center decks on both sides into the lift. The clearance between the wheel stands and the center decks can be reduced by washers.

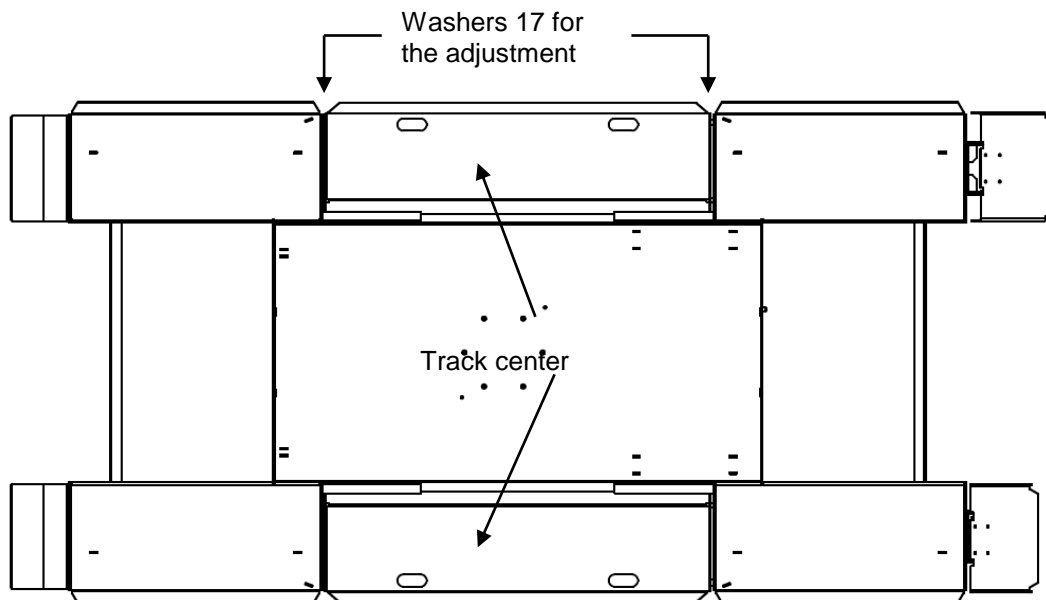

Pic. 9: Hooking in the center decks

Commissioning

The commissioning can be carried out according to chapter “**Operation**” of the manual.

7.5 Electrical grounding, electrostatic charging

When installing the lift HLS1600-14 in hazardous areas, all metal parts have to be grounded to prevent electrostatic charging. Components for the grounding are not included in the scope of delivery of the lift. They must be ordered separately as accessories from the manufacturer.



All installed and removable parts, even the inserted grids, have to be grounded for safety reasons. The grounding must be reliable and durable and resist the expected demands. Pay attention to a positive locking connection of the parts.



Metal parts of the equipment are held to be conductive and have to be grounded with each other by electrical bridges to exclude any kind of electrically insulated layers. Paint and powder coatings rust and grease are considered as different layers.

Detailed information from the manufacturer on request:

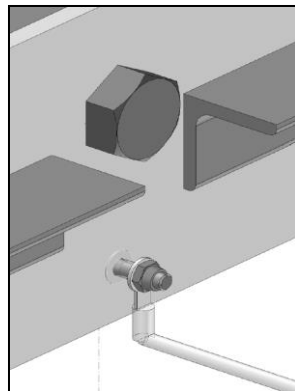

Wire with cable lug
Screw
Serrated washer
Nut

Pic. 10a: Grounding connection at the lift body/center of the wheel stand

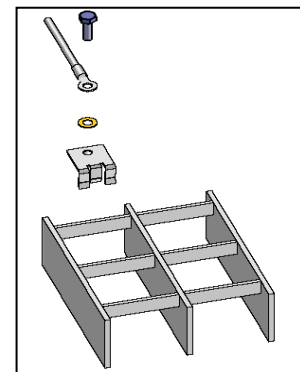

Wire with cable lug
Sheet-metal screw
Serrated washer
Bracket

Pic. 10b: Grounding connection to the grid

Indications for the grounding:

- All grids have to be connected reliably to the lift body/wheel stands and to each other. The corresponding parts are packed with the accessories.
- The grounding cable from the inserted grids to the grounding connection of the lift body has to be connected correctly (metallic contact).
- The compressed air lines from the lift have to be fixed in a distance of 19.69" (50 cm) with hose clamps to the steel construction.
- The grounding wire from the lower frame of the lift has to be properly connected and grounded to the in-house connection of the grounding (e.g. metal construction at the paint booth).
- All components of the lift must be examined before the installation and after any maintenance for sufficient grounding.
- When operating the lift, make sure that wear, dirt, dust deposition or changes in the chemical and physical properties do not affect the explosion protection.
- Consult a qualified electrician if you don't understand the grounding instructions.

8 Operation

When operating the lifting platform, the following safety instructions and the safety instructions in chapter “**General safety information**” must be followed without exception – this will prevent severe injury to personnel, damage to the machine and other material damage.

The lifting platform may only be used according for its intended use.

Inform yourself before using the lifting platform on the correct behavior in the case of breakdown.



People who work with the lift must wear safety shoes and be familiar with the operating instructions.

8.1 Description of the operating elements

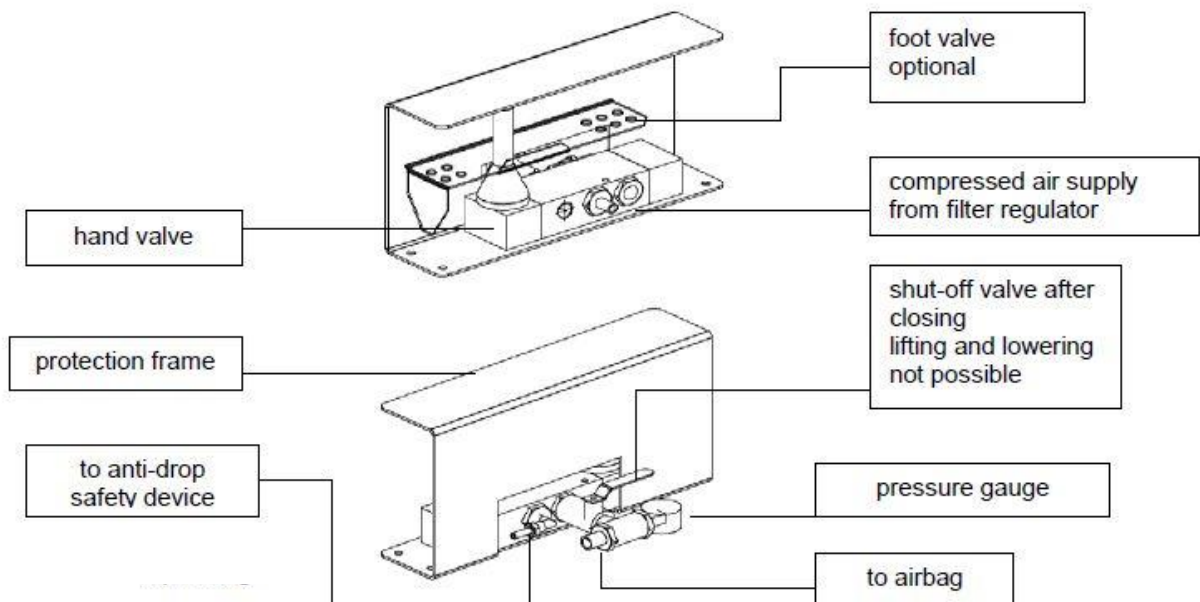

Pic. 11: Operating element

The lifting platform is supplied with either a hand-lever valve, or a foot lever valve. The operating valve has three settings: Lifting, 0 setting, and lowering. The settings are identified accordingly. A solid frame protects the operating valve. The pressure gauge indicates the pressure in the air bag.



Always observe the safety instructions when operating the platform!

8.2 Working at the lifted vehicle

- Follow the legal regulations for the prevention of industrial accidents.
- Make sure that no one is in the space under the lifted vehicle.
- It is not allowed to put spare parts or tools on the lifted vehicle or lifting platform.
- The load-carrying equipment and the vehicle must not be set into vibration.
- Pay attention to the shift of the center of gravity when installing or dismantling heavy parts to or from the vehicle.



Secure the vehicle against tilting.

8.3 Commissioning

Perform the function controls before using the lift:

- Make sure that no persons or objects are in the working area of the lift.
- Ensure that the compressed air is available.
- Check if the stop valve of the operating element is opened.
- Bring the lever of the valve in the position Lift-UP until the platform reaches the maximum height.
- Bring the lever of the valve in the position lower-DOWN until the lift stops automatically.
- Release the lever of the valve to the position 0 – The lift should stop.
- Repeat lifting and lowering several times without load.
- The safety catch should engage after every lifting process or in intermediate position on both sides into the tooth system

Observe the operating instructions for the working places at the lift.

During the operation, only the operating personal is allowed to stay near to the lift.

See as well chapter “**General safety information**”.

8.4 Operate

The safety measures of the chapter “**General safety information**” must be read carefully before the commissioning and strictly observed during the handling.



It is essential that you maintain visual contact with the lifting platform and the vehicle at all times during the lifting and lowering.

Driving onto and leaving the lifting platform

- Make sure that the platform is at the lower setting, the centre decks are inserted into the wheel stands and the drive-on ramps are inserted into the holder.
- Drive the vehicle onto the lifting platform over the access ramps, wheel stands and the centre decks positioned between them. Make sure that you do not drive over the anti-roll off safety device at the front.
- Make sure that the vehicle is located centrally lengthways and crossways on the platform. Secure the vehicle against rolling back, tighten the hand brake, and put the vehicle into gear. Drive off the lifting platform in reverse order to the above.

OPERATION

To raise the lifting platform proceed as follows:

- Make sure that the lifting platform can be raised without creating a hazard.
- Set the switch lever to “lift-UP” and hold it until the vehicle is fully lifted above the wheels.
- Check that the vehicle is securely seated on the lifting platform
- Continue the lifting procedure until you reach the required height. Once the required height has been reached, move the switch lever to the 0 setting. The lifting platform will now remain at this height. If you let go of the switch lever, it automatically reverts to 0-setting and lifting stops. Lifting ends automatically once maximum lifting height has been reached.



While raising, make sure that the anti-drop safety device is safely locked into the gear teeth on both sides at the end of each lifting process (particularly with intermediate positions shorter than maximum lift). This is the case if you hear a clearly audible "clicking" noise. It is not allowed to perform any activity under the lift while it is loaded (e.g. with a vehicle).

To lower the lift proceed as follows:

- Before lowering the platform, it is essential that you check the hazardous area. No person or object must remain in the working area of the lifting platform.
- Set the operating lever of the operating valve to “Lower“ and, while constantly observing the car-lift, hold the lever in place until the car-lift automatically stops approx. 4.72” (120 mm) above the floor.
- The lowering process ends once the lifting platform has reached its initial setting. It is possible to interrupt the lowering process at any time by moving the switch lever to the 0-setting. If you let go of the switch lever during the lowering process, it automatically reverts to 0-setting and movement is stopped

Anti-drop safety device

- During the lifting process to maximum height, the anti-drop safety device is swivelled downwards. The snap tabs of the anti-drop safety device slides on both sides over the snap cavity on the lower frame. After stop lifting in an intermediate position the anti-drop safety device has to snap in on both sides for security.

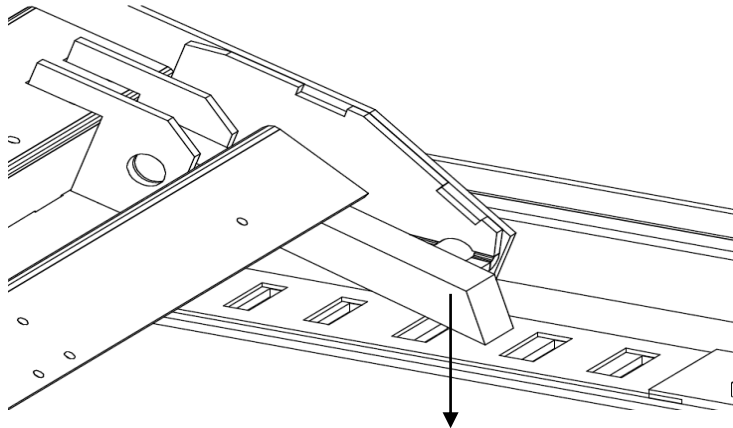
Image no. 12: lifting up - anti-drop safety device swing in

- During the lowering process in initial position the anti-drop safety device is swung out over the cylinder. After stop lowering, the snap tabs of the anti-drop safety device fall down immediately.

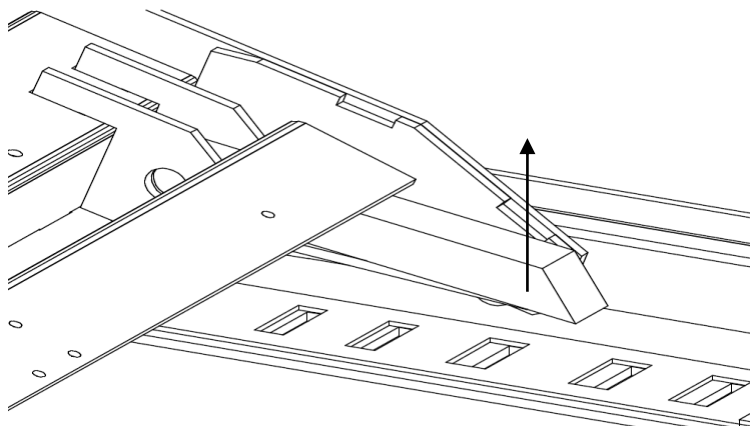
Image no. 13: lowering - anti-drop safety device swung out upturned

Should the lifting platform not descend, the anti-drop safety device could be actuated by a possible leaky air duct. In this case, set briefly the levers on "Lift" again until anti-drop safety device is free. Afterwards, repeat lowering process.

Operate the lifting platform

During the work on the lifting platform, secure the vehicle against rolling off, engage the gear and handbrake. See section no. 6 „General safety information“

If the technical condition of the vehicle does not allow like prescribed above, it is possible to use for example chocks under the wheels (not included in delivery).

Using air jacks or the like on the lifting platform is prohibited.

OPERATION

8.5 End of work

After completing work with the service lift the following points should be adhered to:

- The service platform must be in the lower end limit.
- Close the main tap of the operating control unit.
- Guard the main tap from unauthorized use with a padlock (not included in delivery).

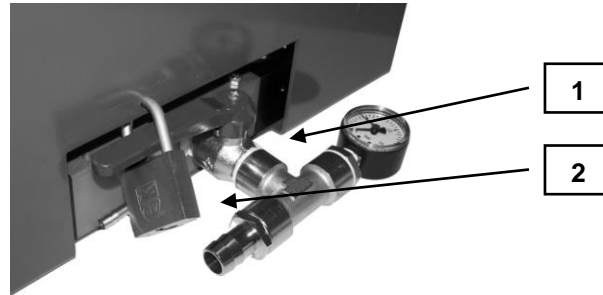

Diagram 9: Operating unit is safeguarded from unauthorized use

No.	Description
1	Main tap locked
2	Padlock (not included in delivery)

Requirements of padlocks:

- padlock width: 1.5" - 1.7" (38-43 mm)
- closed shackle height: 1.1" - 1.4" (28-35 mm)
- shackle diameter: max. 0.23" (6 mm)

9 Troubleshooting

To avoid machine damage or life-threatening injuries while resolving faults with the lifting platform, the following points must be observed at all times:

- Only attempt to repair a malfunction if you are suitably qualified to perform such work.
- Protect the service lift from unintentional restart by disabling the compressed air supply.
- Secure the upper frame in the lifted position with a stand or a proper support.

Also read the **chapter General Safety Instructions**.

9.1 Possible problems and their resolution

Malfunction	Source of fault	Rectification of errors
Malfunction while lifting	Pressure gauge of the maintenance unit without bar mains pressure. Hose lines squashed, bent, or damaged. Gauge pressure 14.5 psi (1 bar) above allowable pressure of the safety valve	Make sure there is a mains pressure of Pmax = 116 psi (8 bar). Open the shut-off valve. Check the hose lines and if necessary replace them with new ones. Check the safety valve for contamination and replace if necessary.
Malfunction while lowering	Lift platform is resting on top of an obstacle Safety catch engaged	Raise the lift platform, remove the obstacle, and then continue lowering. For bar mains pressure Pmax = 116 psi (8 bar) make sure the gear lever is switched to "Lift" until the safety catch is free. Afterwards repeat the lowering movement.



If, despite the above measures, the lifting platform cannot be lifted or lowered, the customer service department must be notified.

Customer service: Hedson Technologies AB
 Hammarvägen 4
 SE-232 37 Arlöv, Sweden
 Phone: +46 40 53 42 00



When replacing defective parts, always only use original spare parts from the manufacturer.

10 Maintenance

Maintenance work should be carried out at the specified maintenance intervals and only by qualified persons. Neither water nor flammable liquids may be used during the cleaning process.

To ensure durability and continuous operation of the service lift, the following points should be observed:



- Only spare parts from the original manufacturer and suitable tools may be used.
- Regular maintenance intervals must be observed.
- For all maintenance work not outlined or explained in this instruction manual, please contact your supplier or customer service of the manufacturer.

Only perform maintenance when the lift achieves a max. (unloaded), the lift platform is braced with service supports, and the compressed air supply is disabled!

Maintenance intervals	Points to follow	Comments
Monthly	<p>All moveable parts such as pivot bolts, sliding pads, and sliding surfaces should be check for wear and tear, cleaned, and lubricated.</p> <p>Check air bags and air tubes for any damages. Visually inspect and check for leaks. Examine the surface of the air bags for impurities, then clean, and maintain.</p> <p>Inspect valves for functionality and check for leaks.</p> <p>Check that the dowels are properly fixed. If necessary re-install or renew the support.</p> <p>Inspect the maintenance unit (filter regulator, provided by the customer), and consult the product manufacturer's instructions.</p>	Only use lubricants that contain no adhesive-repelling substances in the area to be lubricated.
Yearly	Regular safety check (In accordance with §10 (2) German Plant Health and Safety regulations)	For test protocol see chapter Regular safety check.
Replace the safety valve	After every 2 years of operation.	
Every 6 years of operation	Replace the complete air hoses.	

10.1 Air bags characteristics and durability

The air bags are a flexible element developed and designed specifically for use in lift platforms. The rubber covering reduces the aging process and should be especially carefully checked.

Tips for a long operating life:

- Use dry as well as non-lubricated compressed air.
- Protect from UV radiation (i.e. through welding or the use of a UV dryer).
- Avoid the use of chemical agents.
- Protect the unit from damage (grooving, etc.).
- Adhere to maintenance and care instructions (see **chapter Maintenance**).

Damaged air bags must be replaced. Only original parts from the manufacturer are permitted to be used.

10.2 Notice about filter regulator and air line

The filter regulator is not included in the scope of delivery of the lift platform. A filter regulator must be installed in the mains connection (provided by the customer). Only dehumidified, non-lubricated compressed air should be used. Follow maintenance and cleaning of the filter regulator, consult the information and instructions of the filter regulator manufacturer.

10.3 Notice about the sliding area of the scissors

Due to the design principles of the sliding surfaces of the scissors, great force is exerted. This force can lead to scoring on the sliding surfaces. However, the function of the service lift will not be compromised. The maintenance intervals and instructions outlined in the **chapter Maintenance** are to be observed.

10.4 Inspection points, checkpoints and lubrication service points

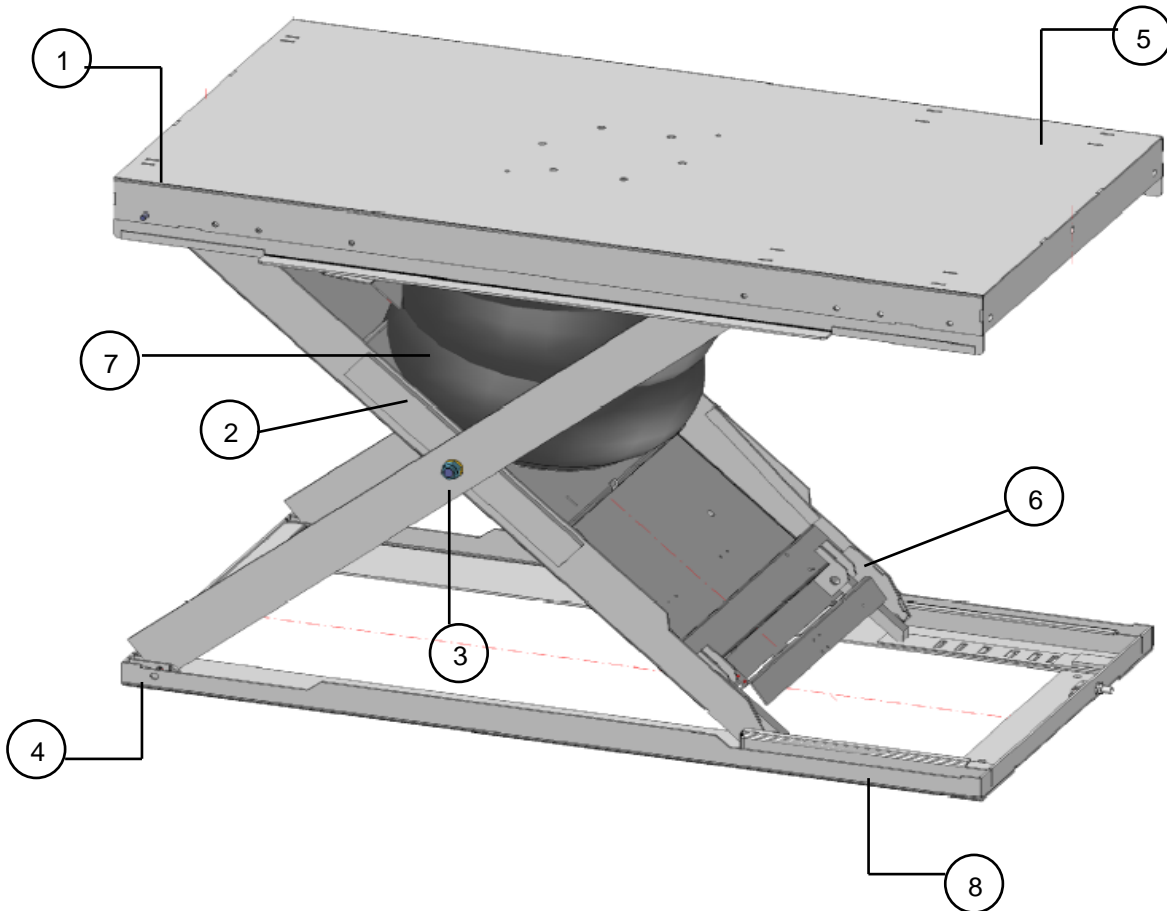

No.	Description	Lubrication and test points
1	bearing pin overhead (right and left)	<ul style="list-style-type: none"> - Check the safety washers from both of the bearing pins for proper fit. - lubricate bearing pin
2	sliding surfaces of the scissors (right and left)	<ul style="list-style-type: none"> - Check the sliding surfaces of the scissors for wear. - lubricate sliding surfaces
3	scissor pins (right and left)	<ul style="list-style-type: none"> - Check that the scissor pins are properly fixed. - Check the safety nuts.
4	bearing pins below (right and left)	<ul style="list-style-type: none"> - Check the safety washers from both of the bearing pins for proper fit. - lubricate bearing pin
5	sliding pads and guide rails above (right and left)	<ul style="list-style-type: none"> - Check sliding pads for damage and wear. - Lubricate sliding pads and guide rails.

6	bearing pin safety catch (right and left)	<ul style="list-style-type: none">- Check the safety washers from both of the bearing pins for proper fit.- lubricate bearing pin
7	air bags	<ul style="list-style-type: none">- Check air bags for damage.- Check the screws on the air bags reinforcement both above and below for proper fit.- Treat the surface of the air bags with the appropriate rubber care product.
8	sliding pads and guide rails below (right and left)	<ul style="list-style-type: none">- Check sliding pads for damage and wear.- Lubricate sliding pads and guide rails.

11 Safety checks

Safety inspection is required to guarantee the operational safety of the service lift.

It should be performed:

Before starting up the lifting platform for the first time by the manufacturer.

The use of which can be found under the section "operation and safety inspection"(**chapter operation and safety inspection**).

After the first commissioning, check at regular intervals in accordance to §10 (2) BetrSichV (German Plant Health and Safety Regulations)!

The use of which can be found under the section "regular safety check"(**chapter regular safety check**).

Document the condition of the service lift in a separate copy and attach it to the operating instructions and inspection log.



Regular safety checks must be performed by a suitably-trained person. It is advisable to also implement maintenance at the same time.

11.1 Regular safety checks

(In accordance with §10 (2) German Health and Safety regulations !)

Device type	
Serial number	

Inspection step	OK	Not OK	re-examination	Remark
Name plate				
Sign with lifting capacity				
Sign with bar mains pressure				
Operating instructions (abbreviated)				
Designation lift - lower				
Secure fit of all supporting screws				
Safeguard of the scissor pins				
condition of the pneumatic lines				
safety valve set to 50.76 psi (3.5 bar) operating pressure				
Pressure gauge bar mains pressure $P_{max} = 116$ psi (8 bar)				
Control lever returns automatically to the '0' position when released				
Safety catch function				
Loading ramps function				
Condition of the air bags				
Roll-off protection function				
Condition of the supporting structure				
Functionality of the service lift with vehicle				
Functionality bogie				

Results	
	Start-up not permitted, verification required
	Start-up possible, faults to be rectified by:
	No fault, start-up possible immediately

Safety inspection performed on:

Name and address of qualified personnel

.....
Signature of competent person

.....
Signature of operator

With the required rectification of faults

.....
Signature of competent person

.....
Signature of operator

12 Additional information

Assembly drawing HLS 1600-11 (drawing K1607-HLS-004-3)

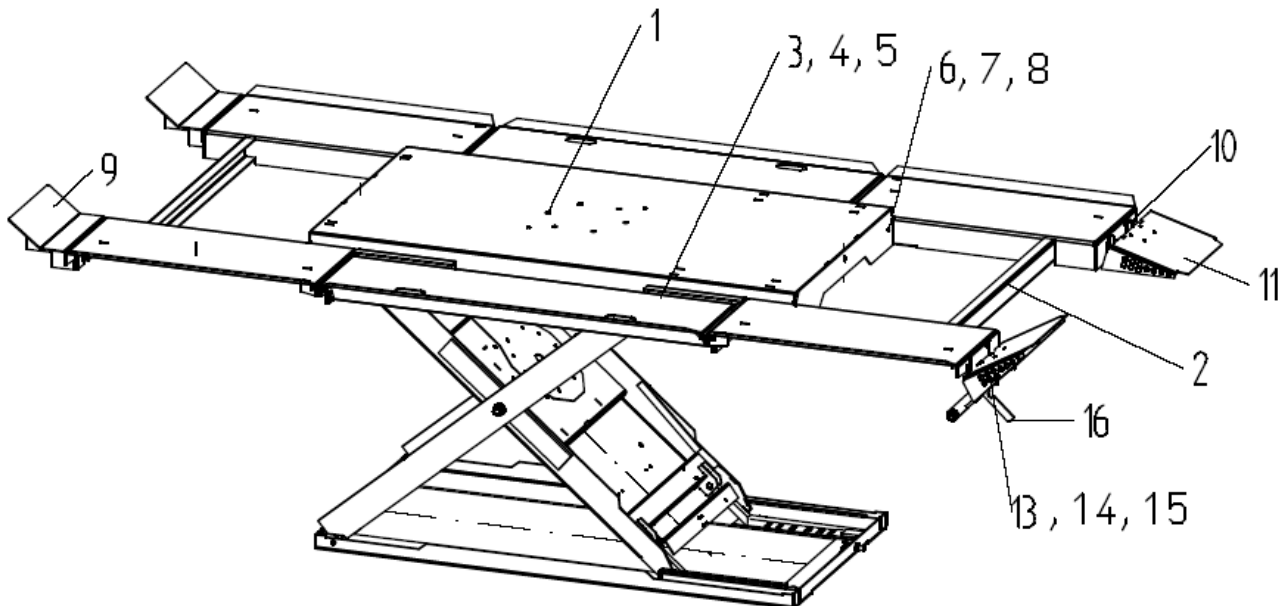

Pcs	Description	No.	Drawing	Article no.
1	Grundkörper	1	K 1607-HLS-000-3	
2	Ausleger	2	K 1607-HLS-090-2	
16	Senkschraube M12x35	3	Befestigung Ausleger	500-157
18	Sechskantmutter M12	4	Befestigung Ausleger	600-114
18	Scheibe 13	5	Befestigung Ausleger	650-113
6	Sechskantschraube M16x35	6	Befestigung Ausleger	500-103
6	Sechskantmutter M16	7	Befestigung Ausleger	600-120
10	Scheibe 17	8	Befestigung Ausleger	650-117
2	Abfallsicherung/Überrollschutz	9	K 1600-HLS-089-3	
2	Rampenhalter	10	K 1600-HLS-084-3	
2	Auffahrrampe	11	K 1600-HLS-083-2	
2	Fahrbahn Mitte	12	K 1600-HLS-060-2	
2	Sechskantschraube M12x40	13	Befestigung Pos.16	500-177
16	Sechskantschraube M10x30	14	Befestigung Pos.9.10	500-099
16	Sechskantmutter M10	15	Befestigung Pos.9.10	600-110
2	Arretierung, Sperre	16	K 1600-HLS-085-3	
6	Schraube 12x100	17	Befestigung Fundament	505-125
6	Dübel S16	18	Befestigung Fundament	810-155
6	Scheibe 13	19	Befestigung Fundament	660-113

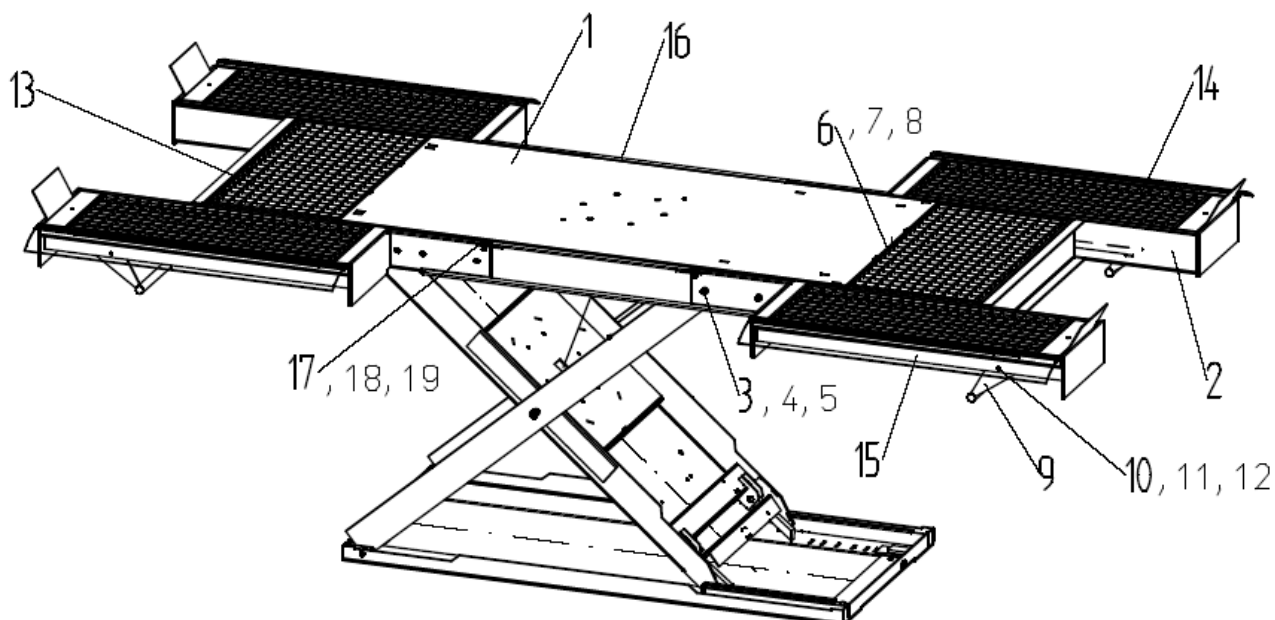
Assembly Drawing HLS 1600-14 (drawing K1607-HLS-002-3)

Pcs	Description	No.	Drawing	Article no.
1	Grundkörper	1	K 1607-HLS-000-3	
2	Ausleger Einbau	2	K 1607-HLS-101-3	
16	Sechskantschraube M12x35	3	Befestigung Ausleger	500-157
16	Sechskantmutter M12	4	Befestigung Ausleger	600-114
16	Scheibe 13	5	Befestigung Ausleger	650-113
6	Sechskantschraube M16x35	6	Befestigung Ausleger	500-103
6	Sechskantmutter M16	7	Befestigung Ausleger	600-120
6	Scheibe 17	8	Befestigung Ausleger	650-117
4	Ausleger Abrollsicherung	9	K 1600-HLS-115-3	
8	Sechskantschraube M8x30	10	Befestigung Pos.9	500-153
8	Sechskantmutter M8	11	Befestigung Pos.9	600-108
8	Scheibe 8,4	12	Befestigung Pos.9	650-105
2	Gitterrost verzinkt 510x1038x40	13	K 1607-HLS-119-3	820-207
4	Gitterrost verzinkt 376x1037x40	14	K 1606-HLS-116-4	820-016
4	Schutzprofil kompl.	15	K 1606-HLS-112-4	810-223
2	Zwischenleiste	16	K 1600-HLS-120-3	
4	Sechskantschraube M8x25	17	Befestigung Pos.16	500-149
4	Sechskantmutter M8	18	Befestigung Pos.16	600-108
4	Scheibe 8,4	19	Befestigung Pos.16	650-105
6	Holzschraube 12x100	20	Befestigung Fundament	505-125
6	Dübel S16	21	Befestigung Fundament	810-155
6	Scheibe 13 groß	22	Befestigung Fundament	660-113

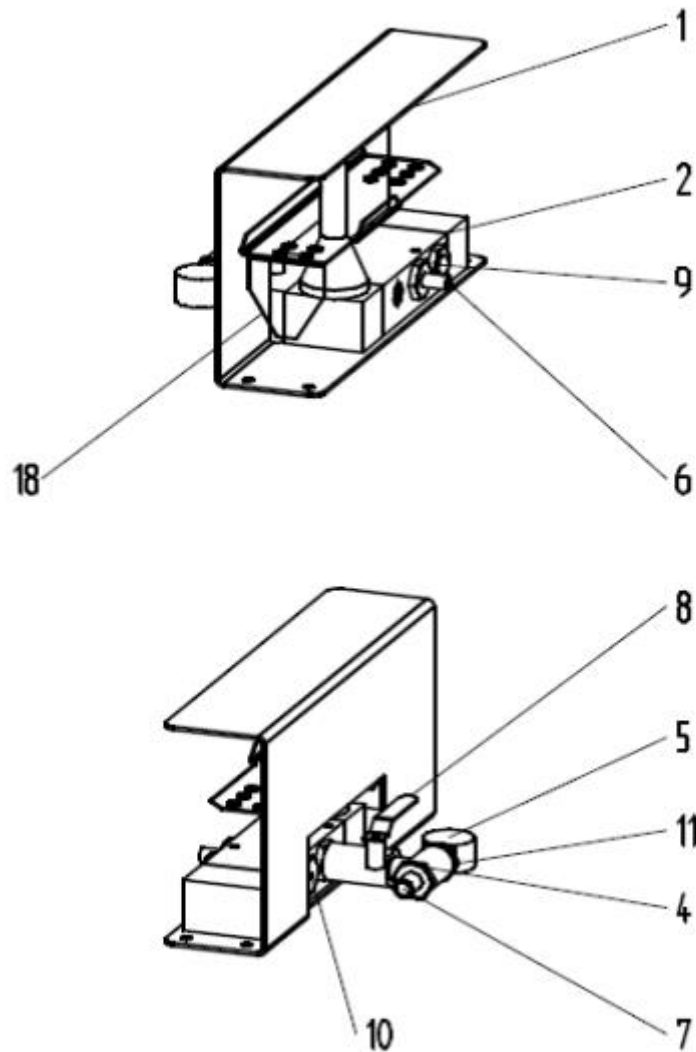
Hand Lever Valve HLS1600 (drawing K 1201-036-4 Blatt 1)

Pcs	Description	No.	Drawing	Article no.
1	Schutzrahmen	1		
1	Handhebelventil	2	1/2"	700-220
1	T-Stück	4	1/2" i 1/2"i 1/2" i	730-068
1	Manometer Ø40	5	1/4" a	735-104
1	Kupplungsstecker	6	1/2" a NW7,2	730-184
1	Schlauchtülle	7	1/2" a Ø13	730-120
1	Kugelhahn	8	1/2" a 1/2a	760-118
1	Schalldämpfer	9	1/2" a Stahlwolle	810-114
1	Blindstopfen	10	1/2" a	730-132
1	Reduziernippel	11	1/2" a 1/4"i	730-151
1	Pedal	18		

ADDITIONAL INFORMATION

HLS 1600-14

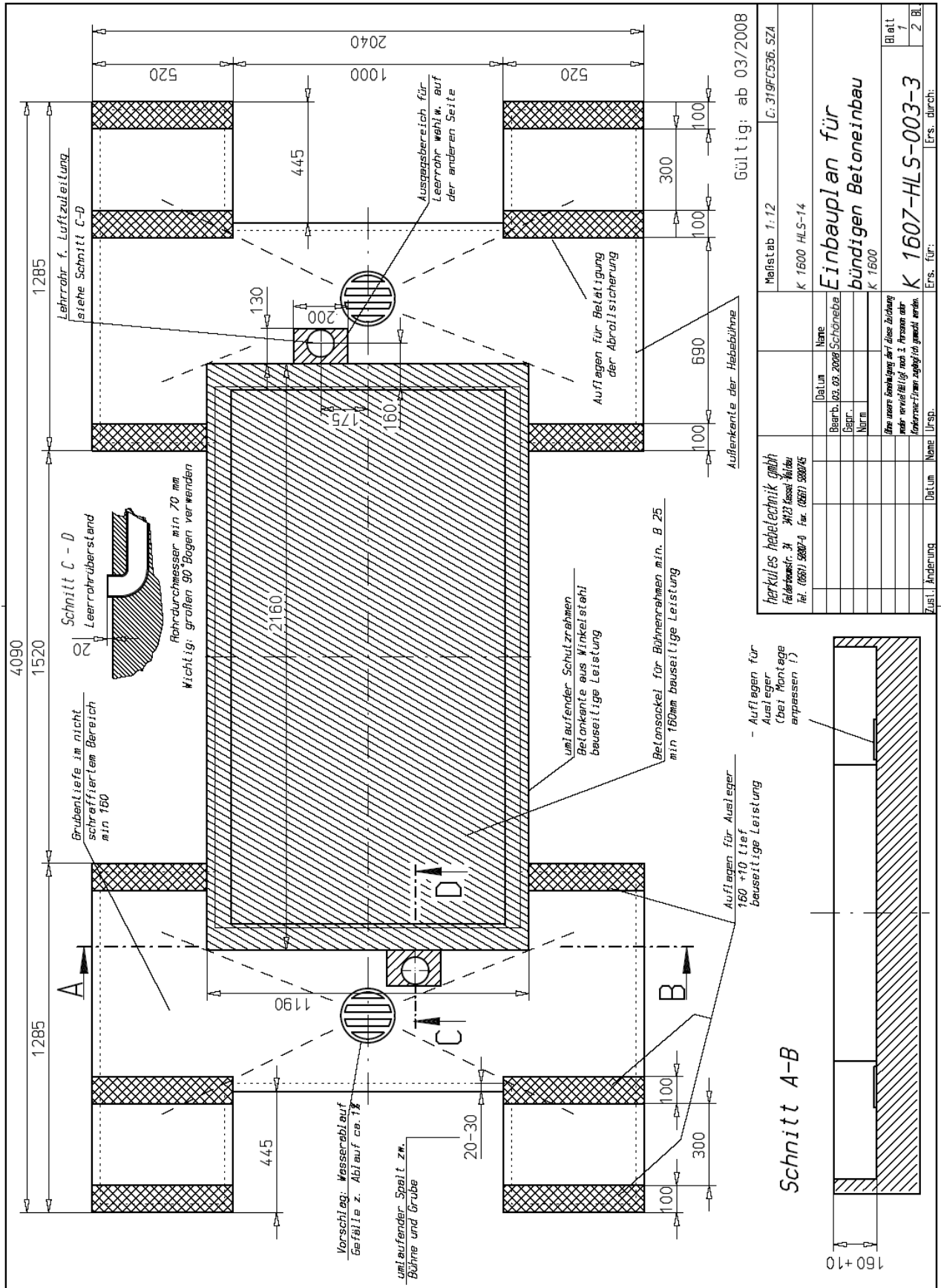

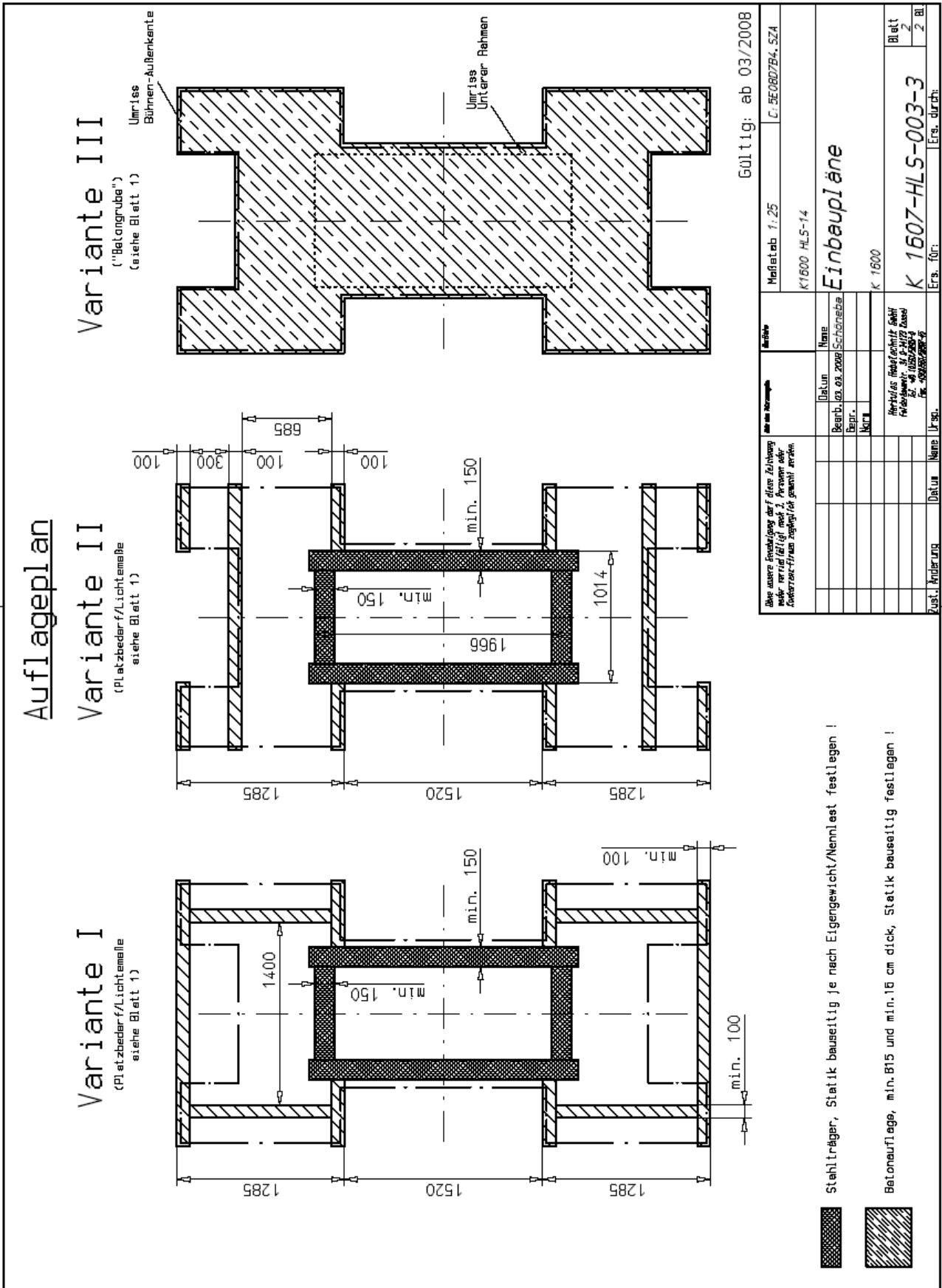

ADDITIONAL INFORMATION

Fundament Frame HLS 1600-14

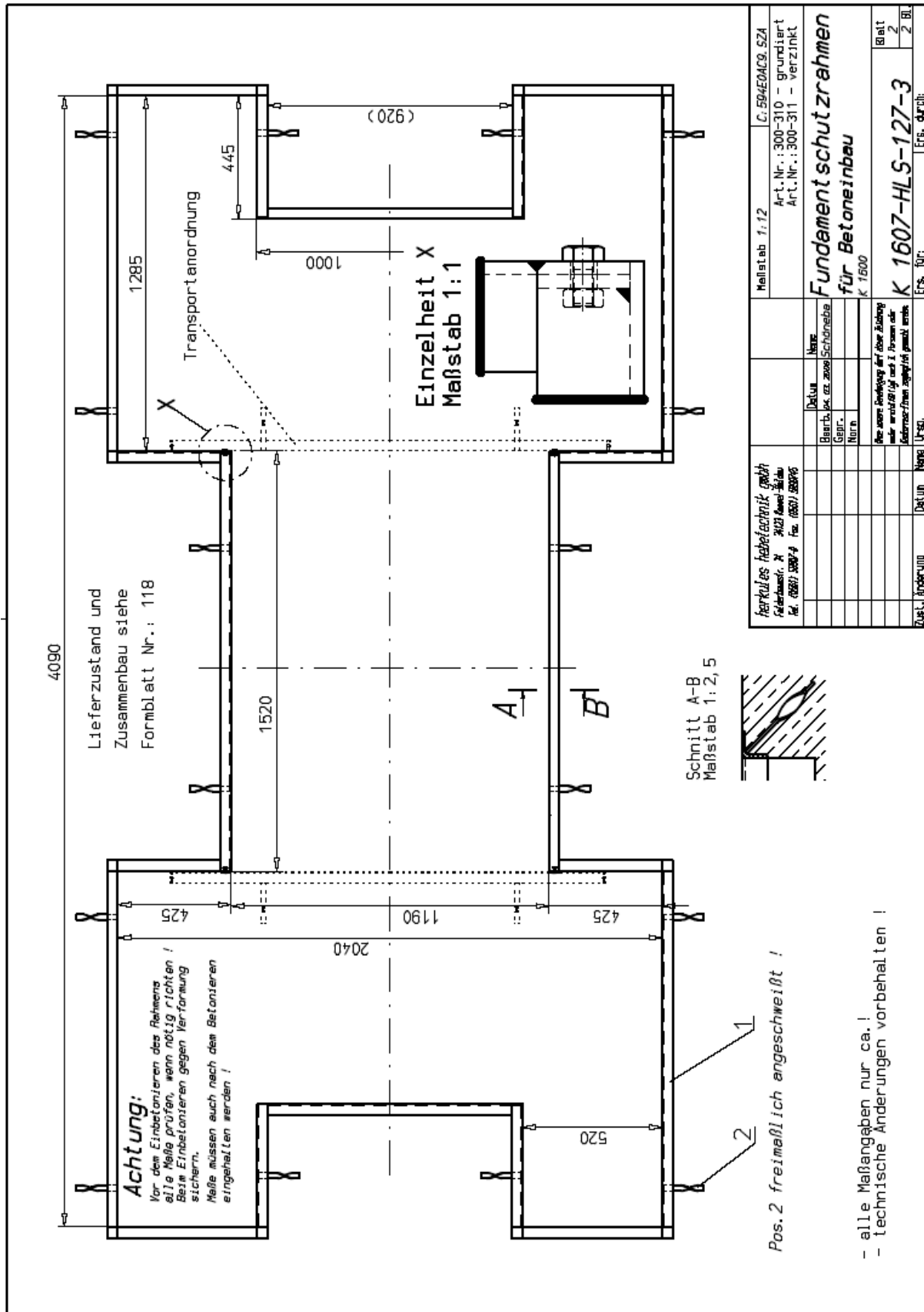

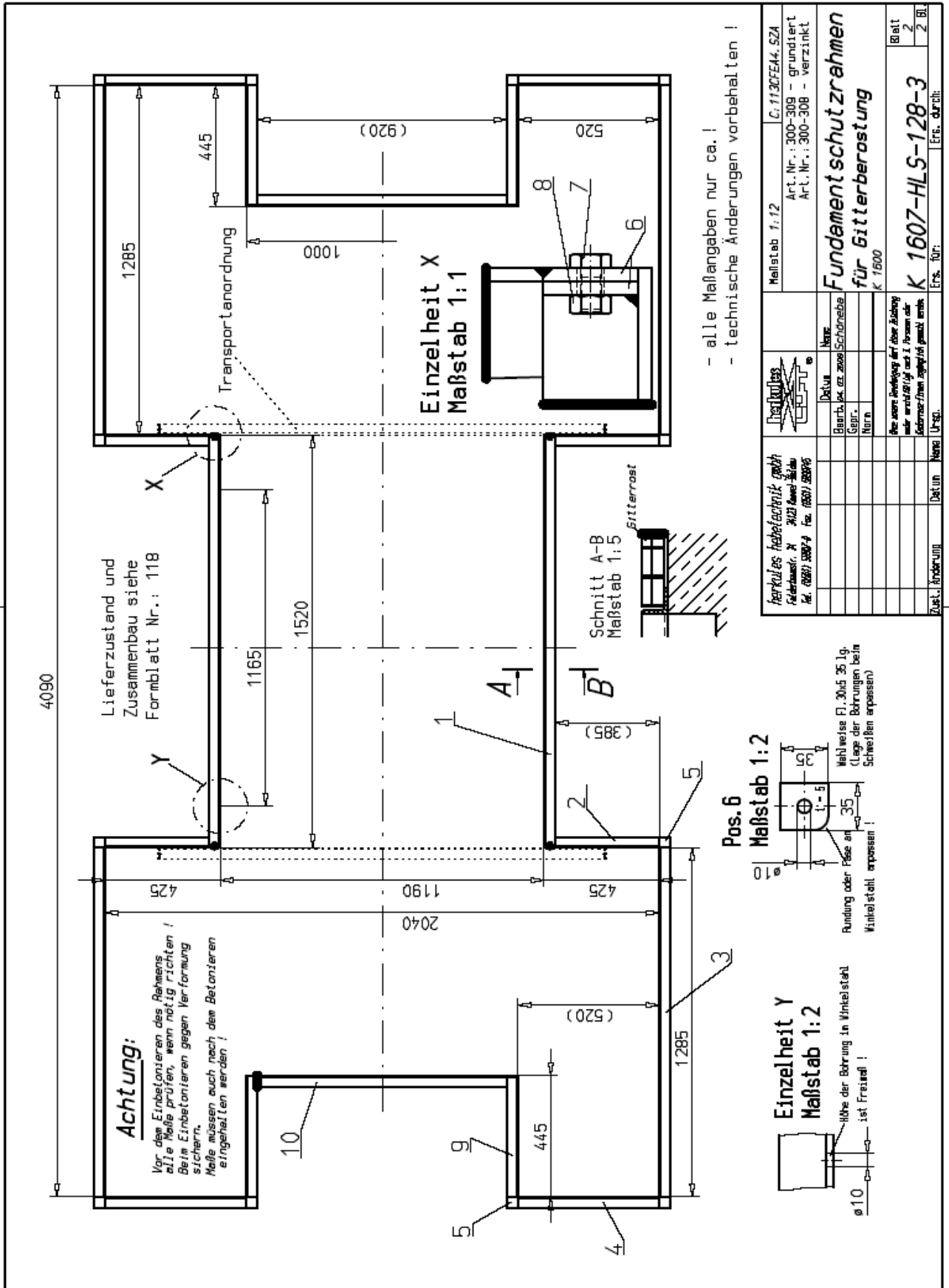

ADDITIONAL INFORMATION

Base body HLS 1600

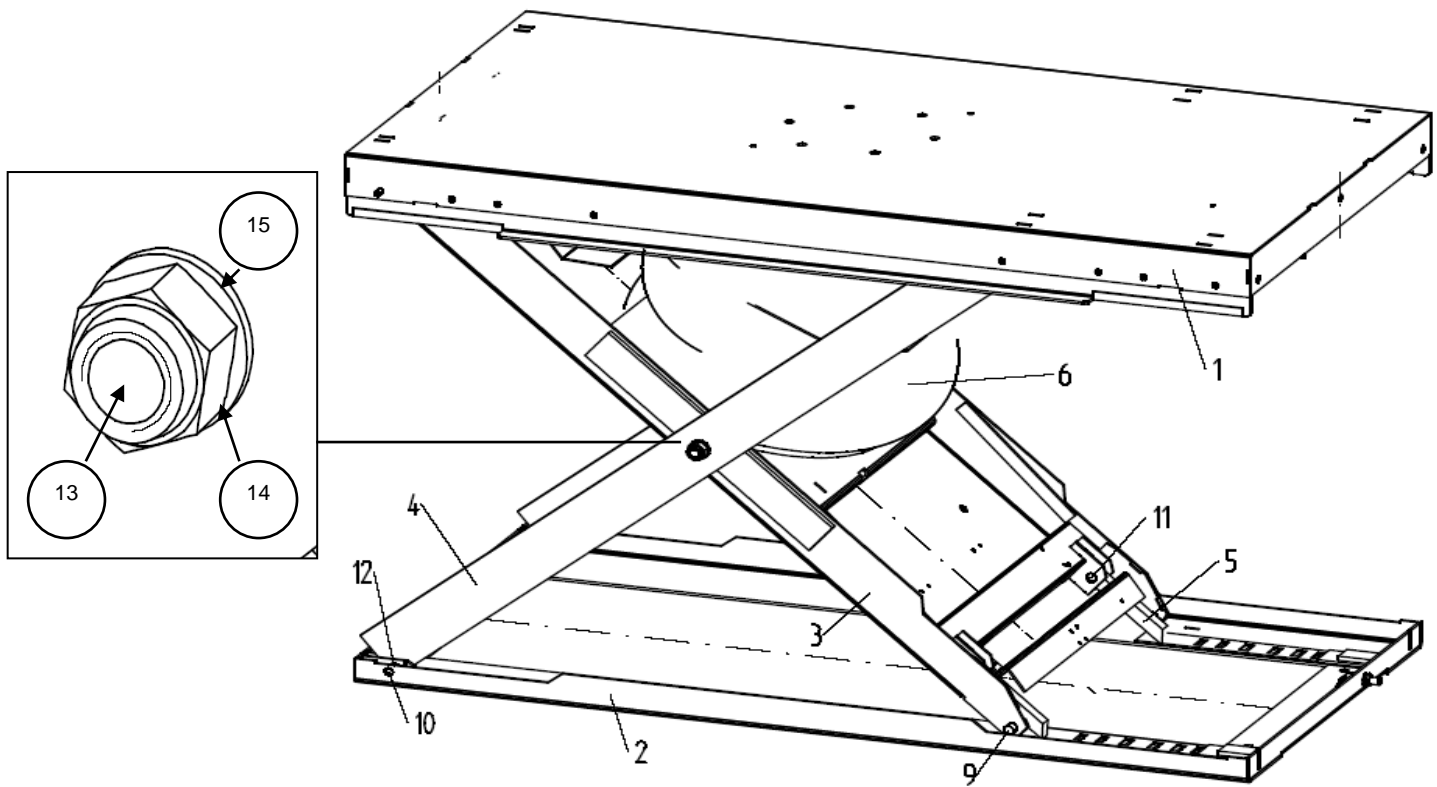

Pcs	Description	No.	Drawing	Article no.
1	Upper Frame	1	K 1607-HLS-010-2	15301
1	Lower Frame	2	K 1607-HLS-020-2	15302
1	Inner Scissor	3	K 1607-HLS-030-2	15303
1	Outer Scissor right	4	K 1606-HLS-040-2	15127
1	Outer Scissor left	4	K 1606-HLS-040-2	15128
1	Anti-drop safety device	5	K 1607-HLS-034-2	15304
1	Pneumatic with airbag	6	K 1607-HLS-008-4	
1	Pneumatic with air bag and CE-Stop	7	K 1606-HLS-028-3 only HLS1600-16	
1	Sliding piece f. anti-drop safety device	8	K 1200-035-4	695-001
6	Sliding piece	9	K 1606-HLS-029-4	695-005
4	Scissor bolts fixed bearing	10	K 1606-HLS-019-4	690-156
2	Bolts of anti-drop safety device	11	K 1606-HLS-027-4	690-157
4	Locking washer f. mandrel	12		650-205
2	Hex screw M24x90	13		500-617
2	Hex screw – safety nut M24	14		500-631
4	Washer 25	15		500-615

Dimension sheet HLS 1600-11

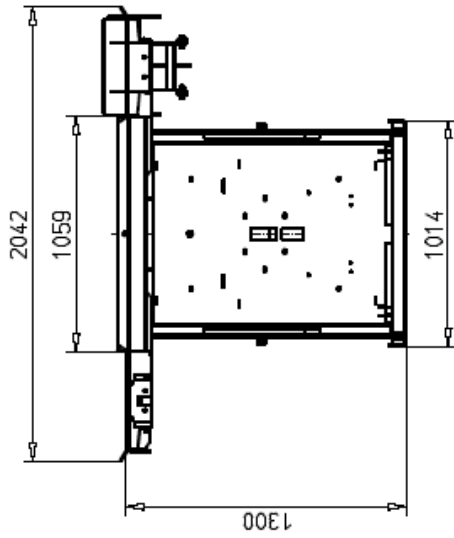

Hubhöhe der Hebebühne 1150mm
 alle Maße sind ca. Angaben
 Technische Änderungen vorbehalten

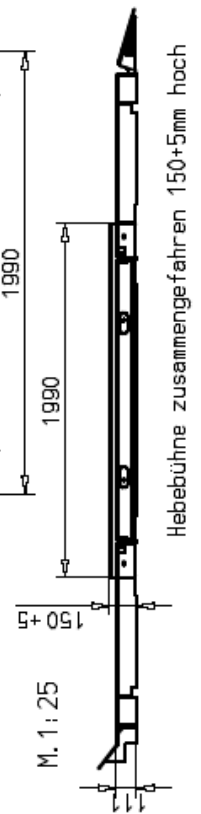
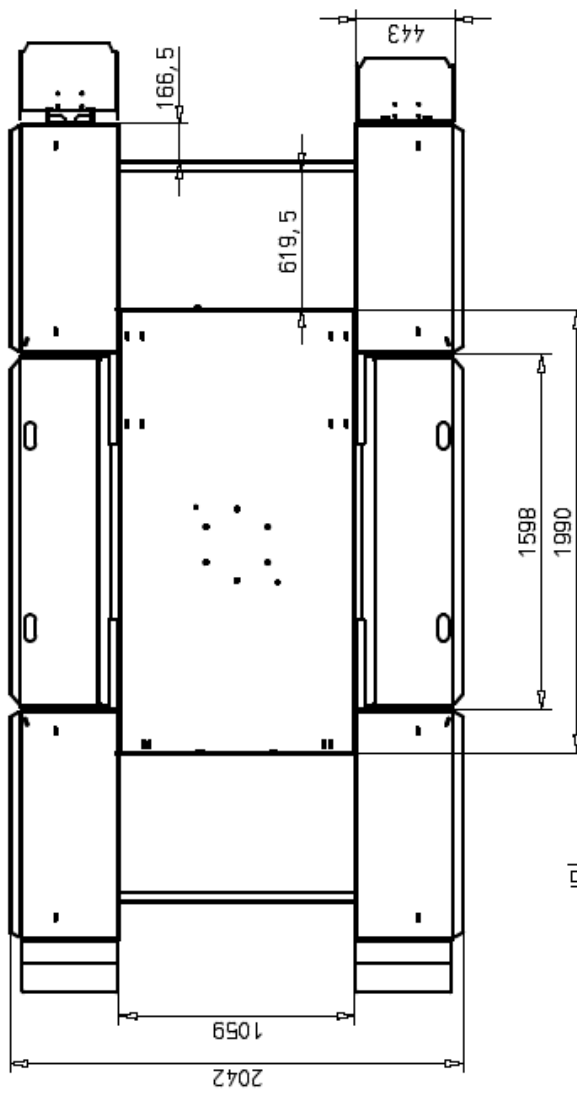
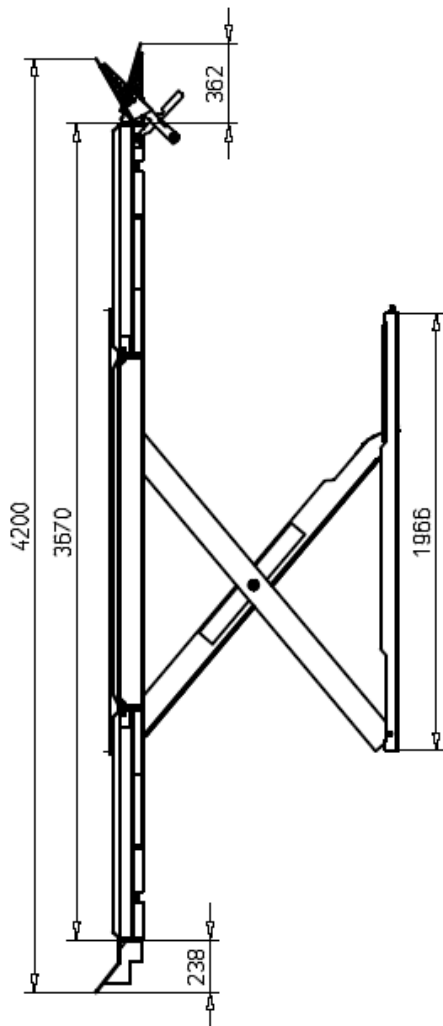

ADDITIONAL INFORMATION

Dimension sheet HLS 1600-14

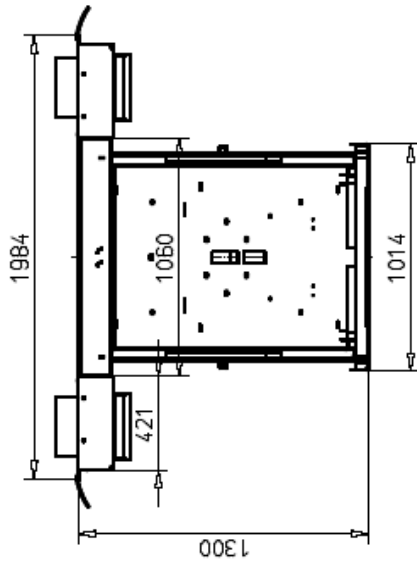

Hubhöhe der Hebebühne 1150mm
 alle Maße, sind ca. Angaben
 Technische Änderungen vorbehalten

