

WATER CLEANING KIT

English // Deutch // Francais // Svenska

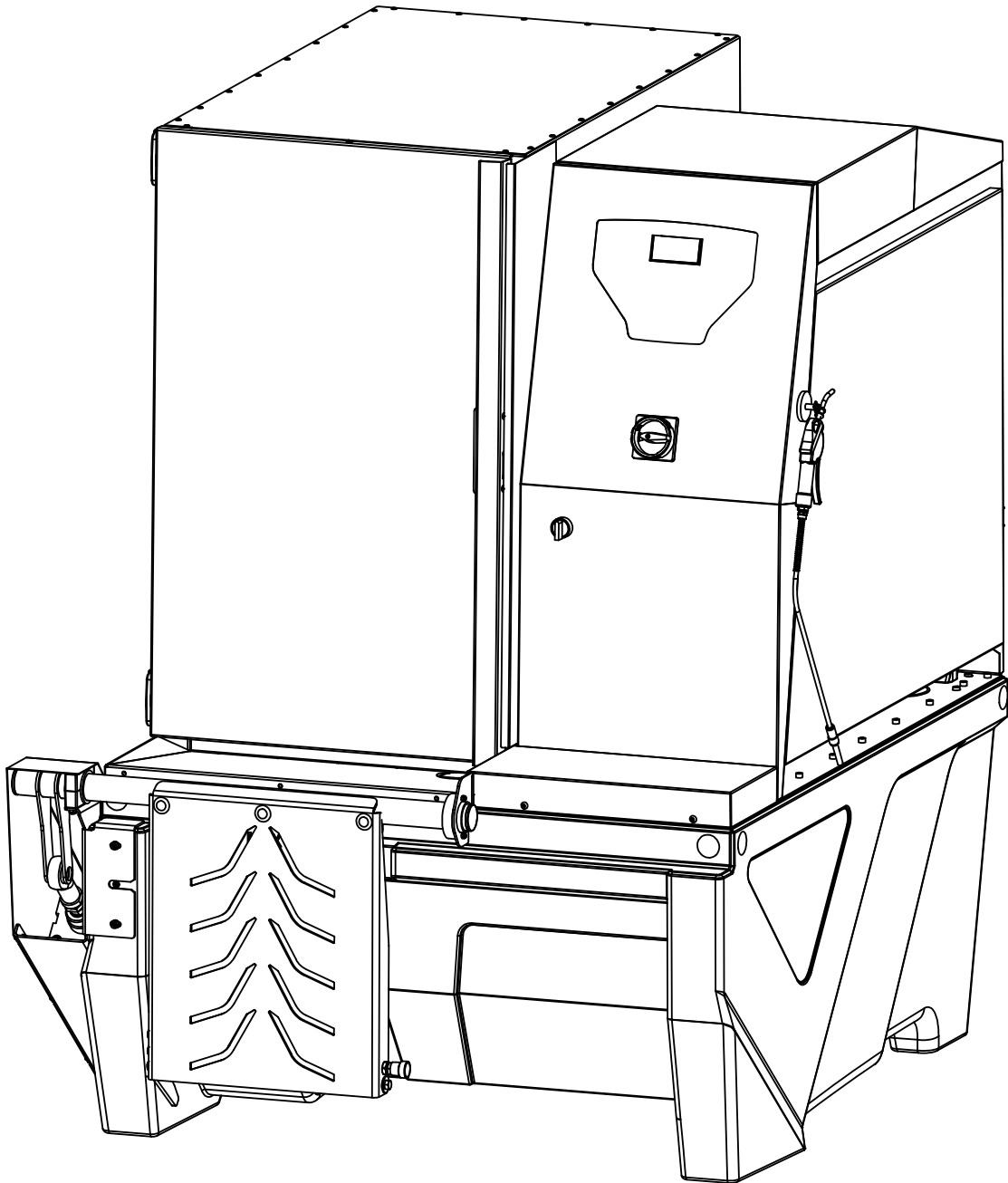

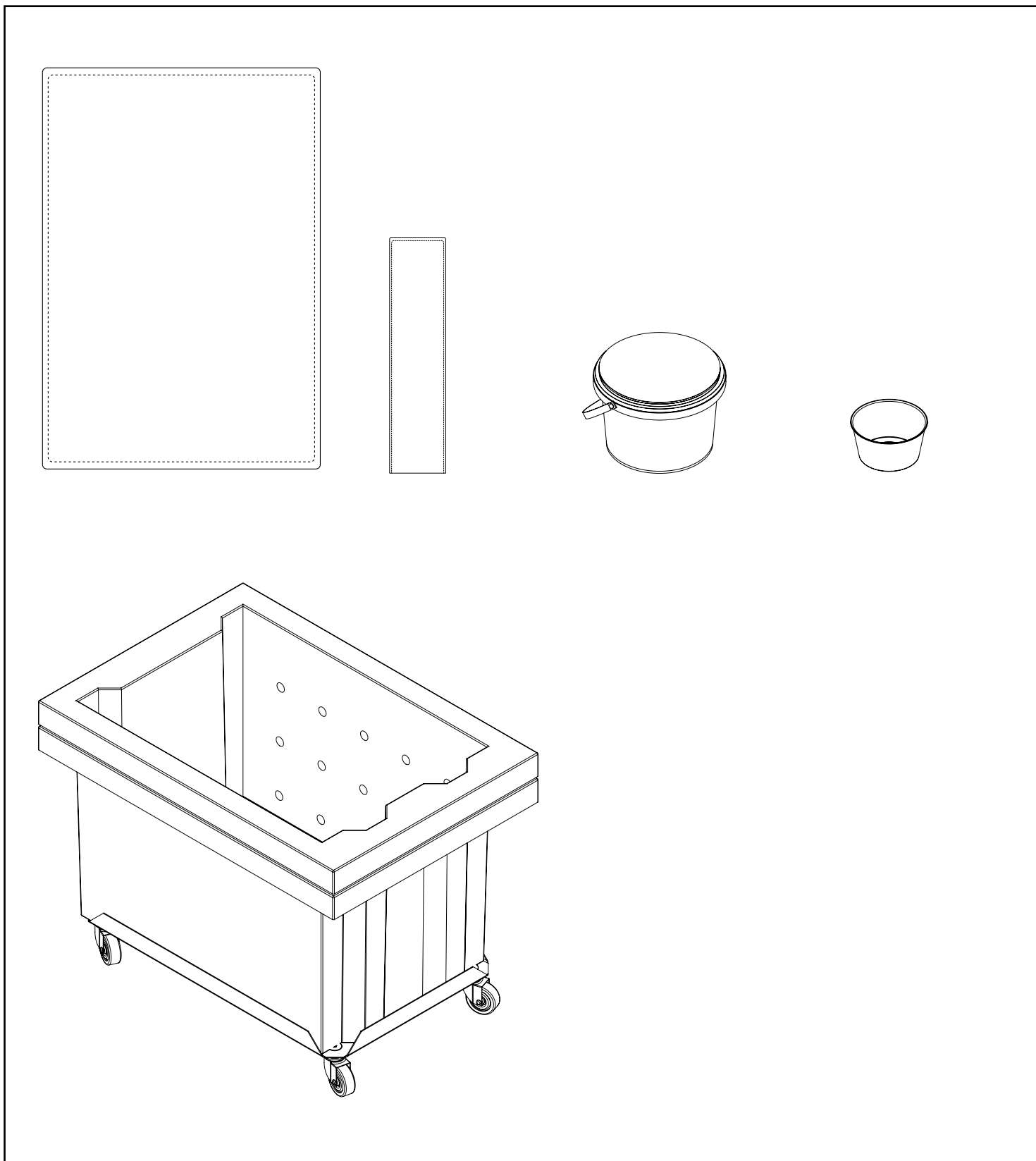

IMPORTANT!

- Please note! BIO-291 or any other detergent must not be used in the machine when using the Hedson water cleaning method!
- Nota! Bio-291 oder ein anderes Waschmittel darf zusammen mit der Hedson Wasseraufbereitungsmethode nicht verwendet werden!
- Nota! Il ne faut pas utiliser BIO-291 ou un autre lessive en poudre quand on utilise la méthode Hedson pour le traitement des eaux!
- OBS! BIO-291 eller annat tvättmedel får inte användas ihop med Hedsons metod för att rena avloppsvattnet!

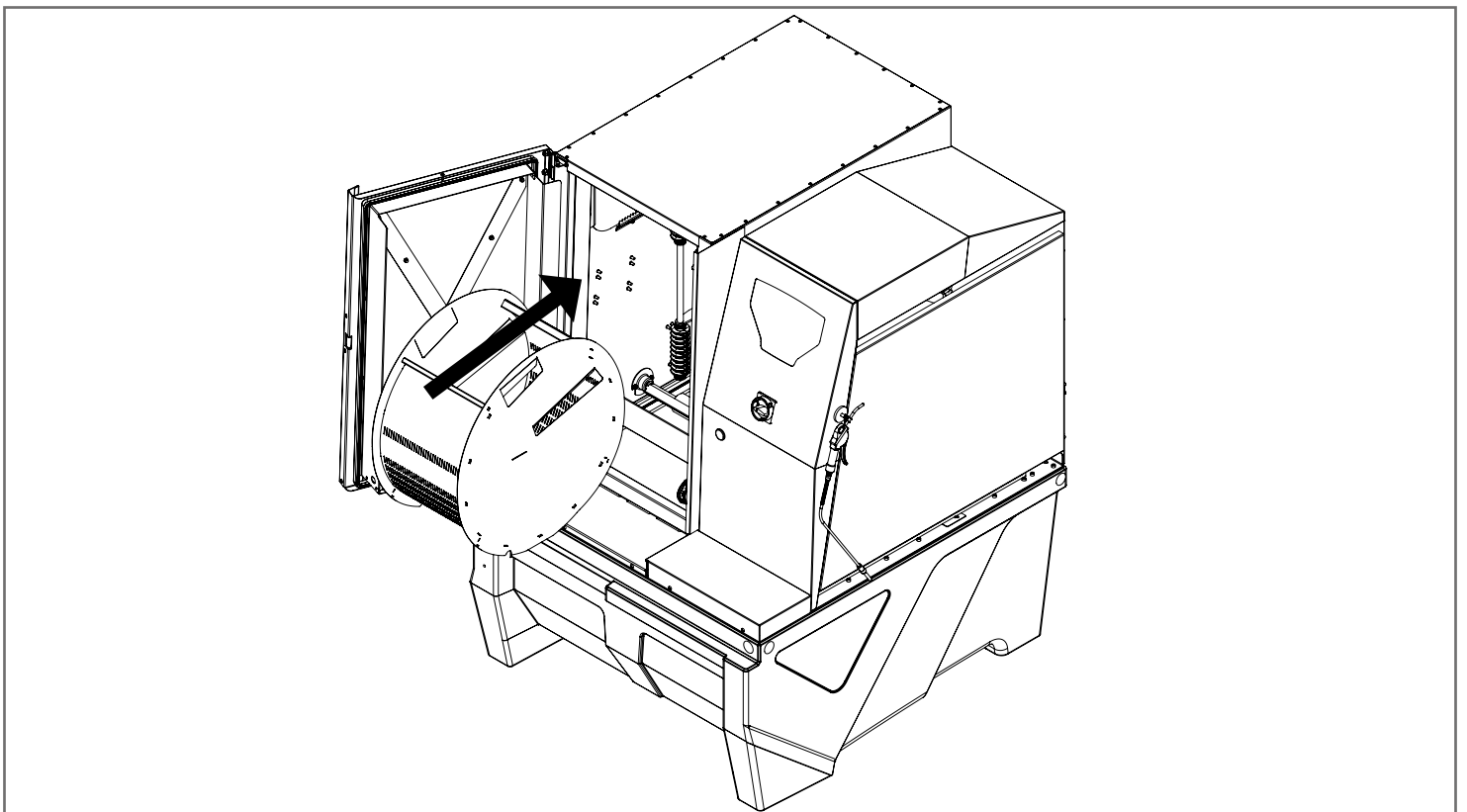
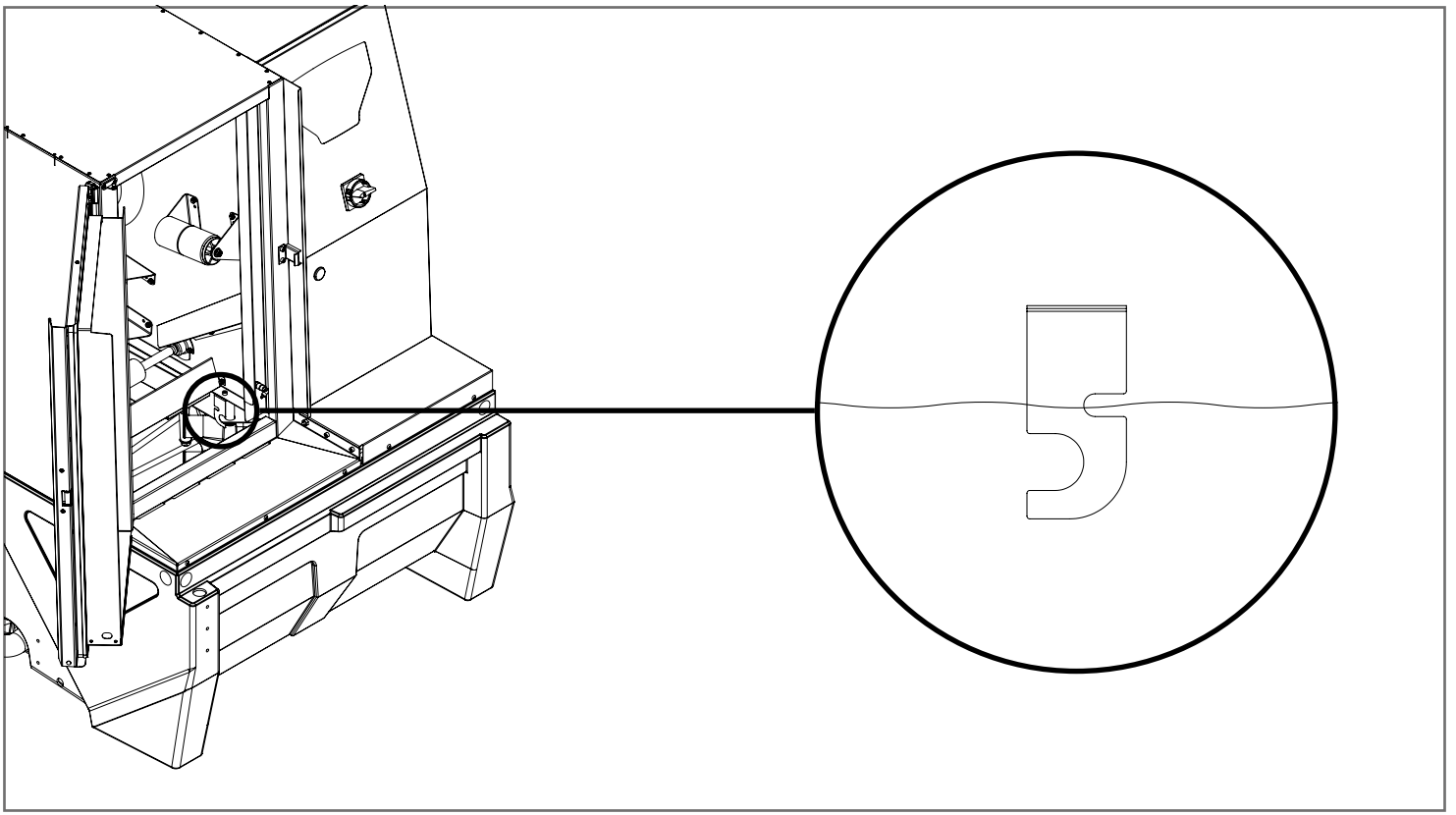

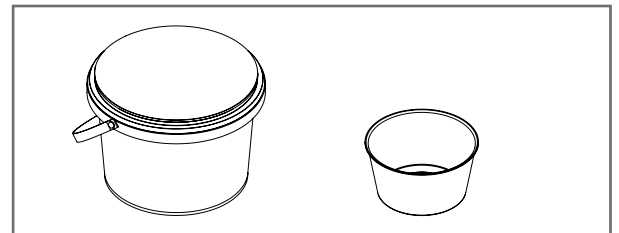
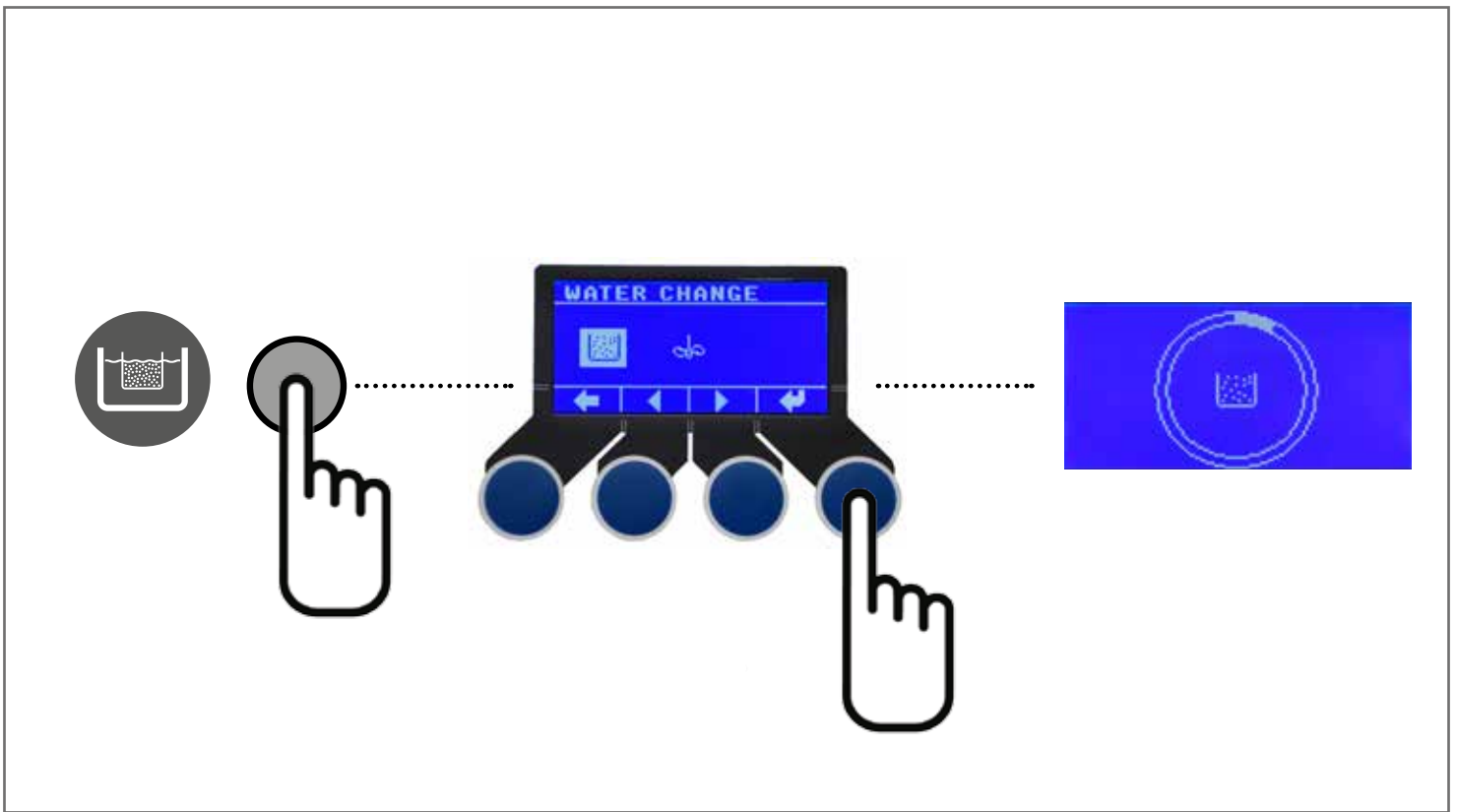

- Add about ½ litre of coagulation powder. Spread slowly into the water, in order to avoid dumplings.
- Etwa ein ½ Liter Koagulationspulver hinzufügen. Das pulver langsam verteilen um Klumpen zu vermeiden.
- Ajouter environ ½ litre de poudre de coagulation. Entaler la poudre lentement dans l'eau, afin d'éviter les boulettes.
- Tillsätt cirka ½ liter koaguleringspulver. Strö pulvret lite i taget så att klumpar undviks.

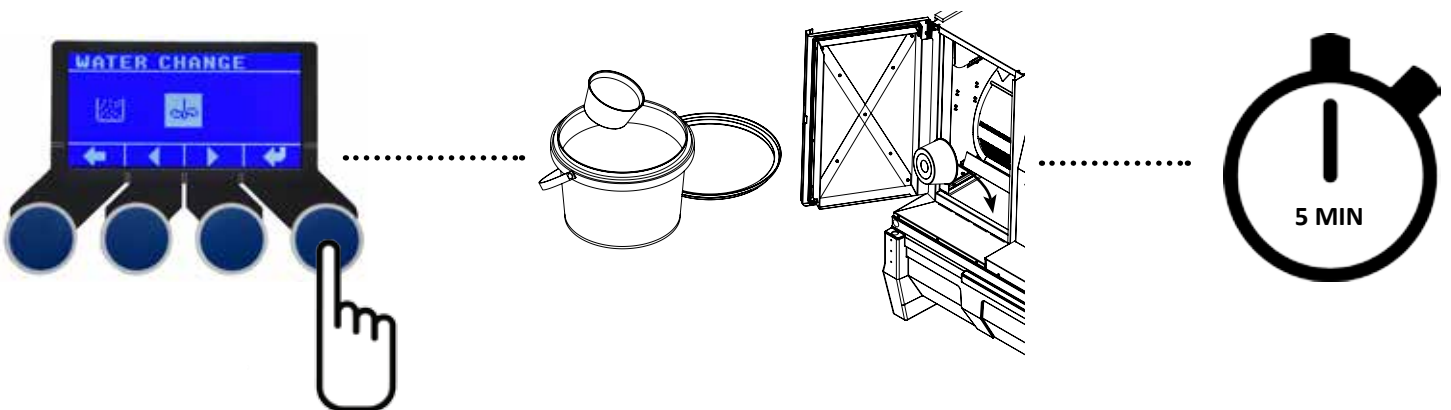

- After 5 minutes of stirring, let the water rest for at least 15 minutes to settle.
- Nach 5 Minuten Umrühren muss das wasser etwa 15 Minuten in Ruhe stehenbleiben um zu Sedimentieren.
- Après 5 minutes d'agitation, laissez reposer l'eau pendant au moins 15 minutes à s'installer.
- Efter 5 minuters omrörning, låt vattnet vila under minst 15 minuter för att sedimentera

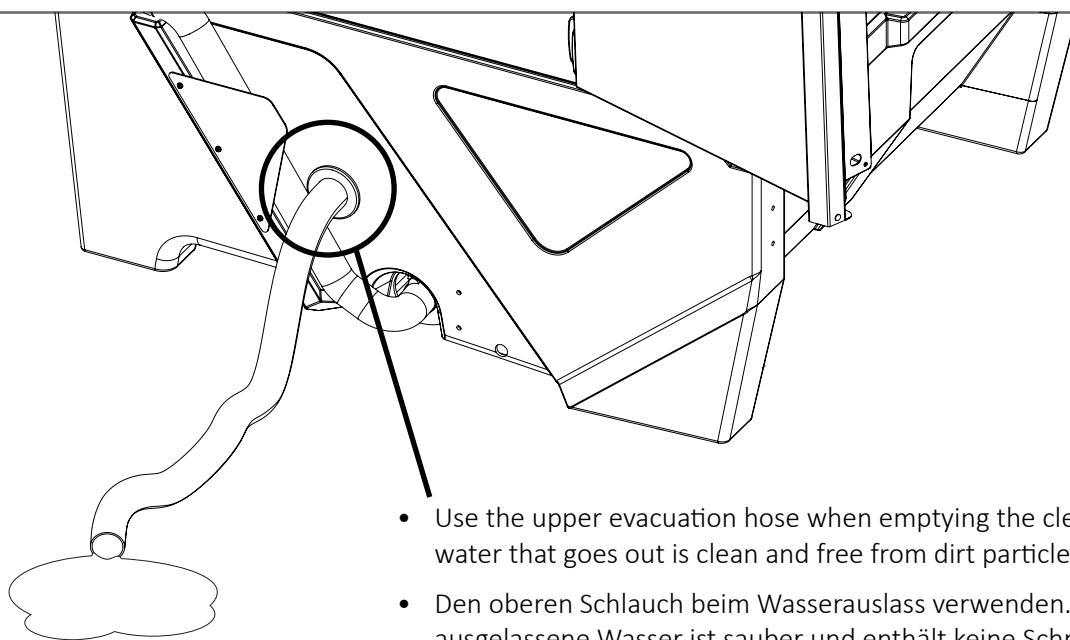
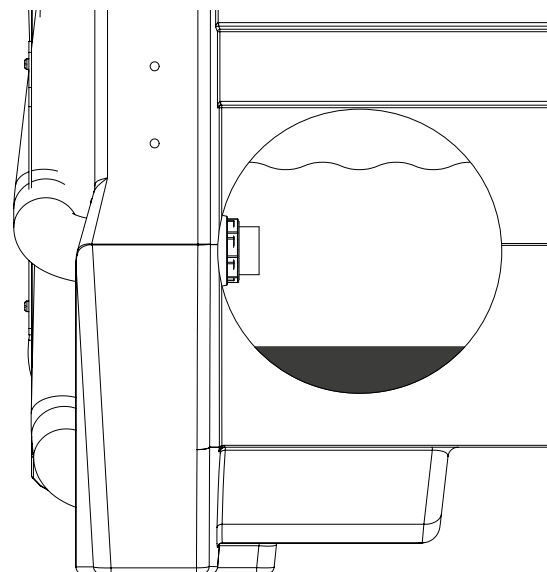
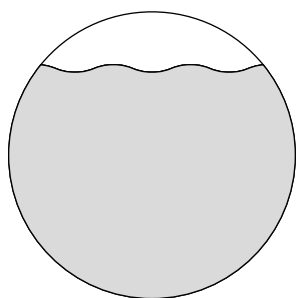

- Use the upper evacuation hose when emptying the clean water. The water that goes out is clean and free from dirt particles.
- Den oberen Schlauch beim Wasserauslass verwenden. Das ausgelassene Wasser ist sauber und enthält keine Schmutzpartikel.
- Utilisez le tuyau d'évacuation supérieure lors de la vidange de l'eau propre. Eau qui sort est propre et exempt de particules de saleté.
- Använd den översta slangen vid tömning av det rena vattnet. Vattnet är rent och fritt från smutspartiklar.

- Attach the hose filter to the lower drainage hose.
- Das Schlauchfilter am Entleerungsschlauch befestigen.
- Fixer le filtre à tuyau sur le tuyau de drainage inférieur.
- Fäst slangfiltret på nedersta tömningsslangen.

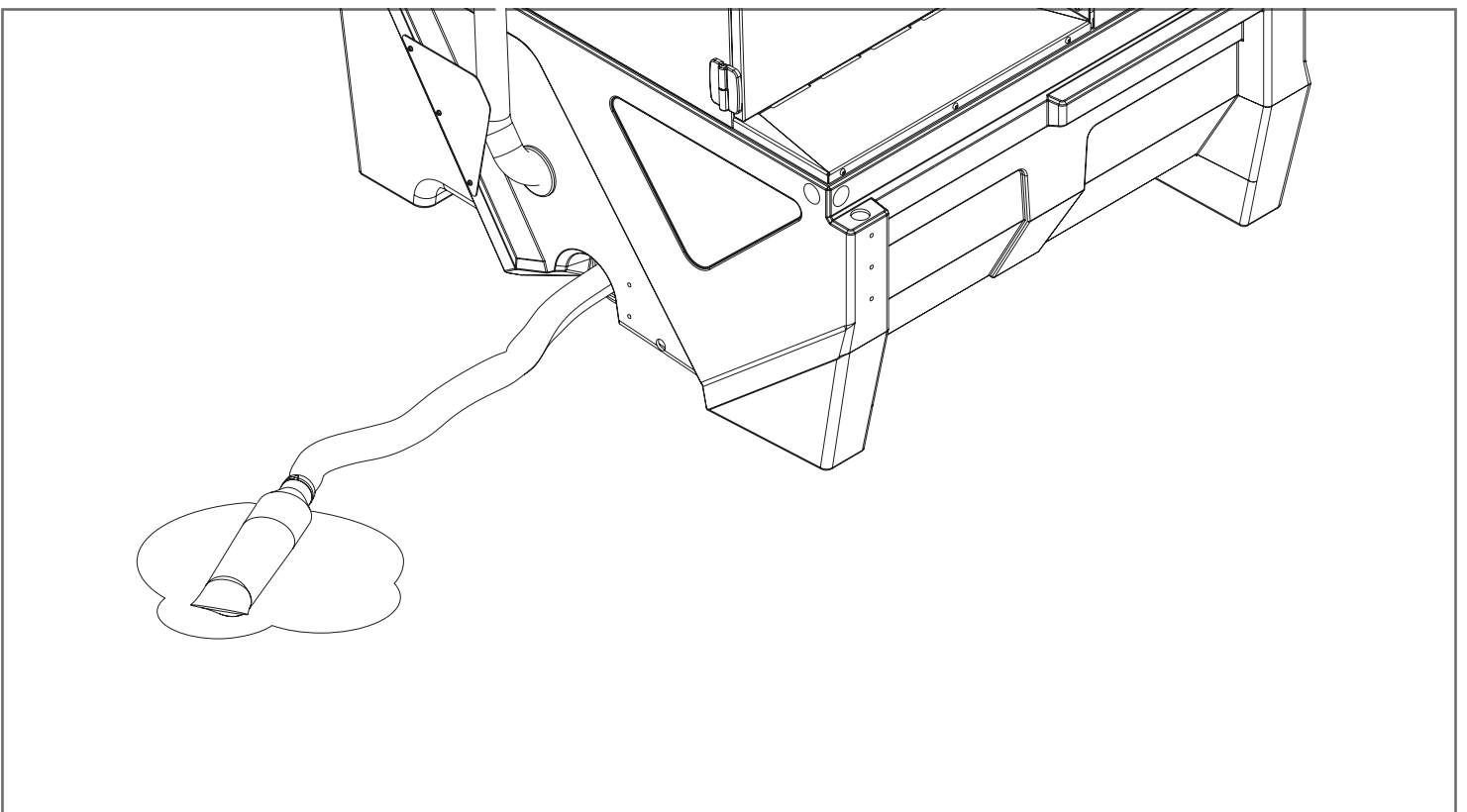
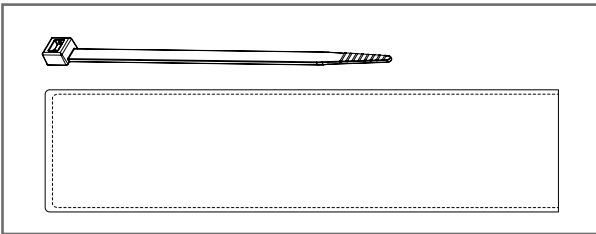
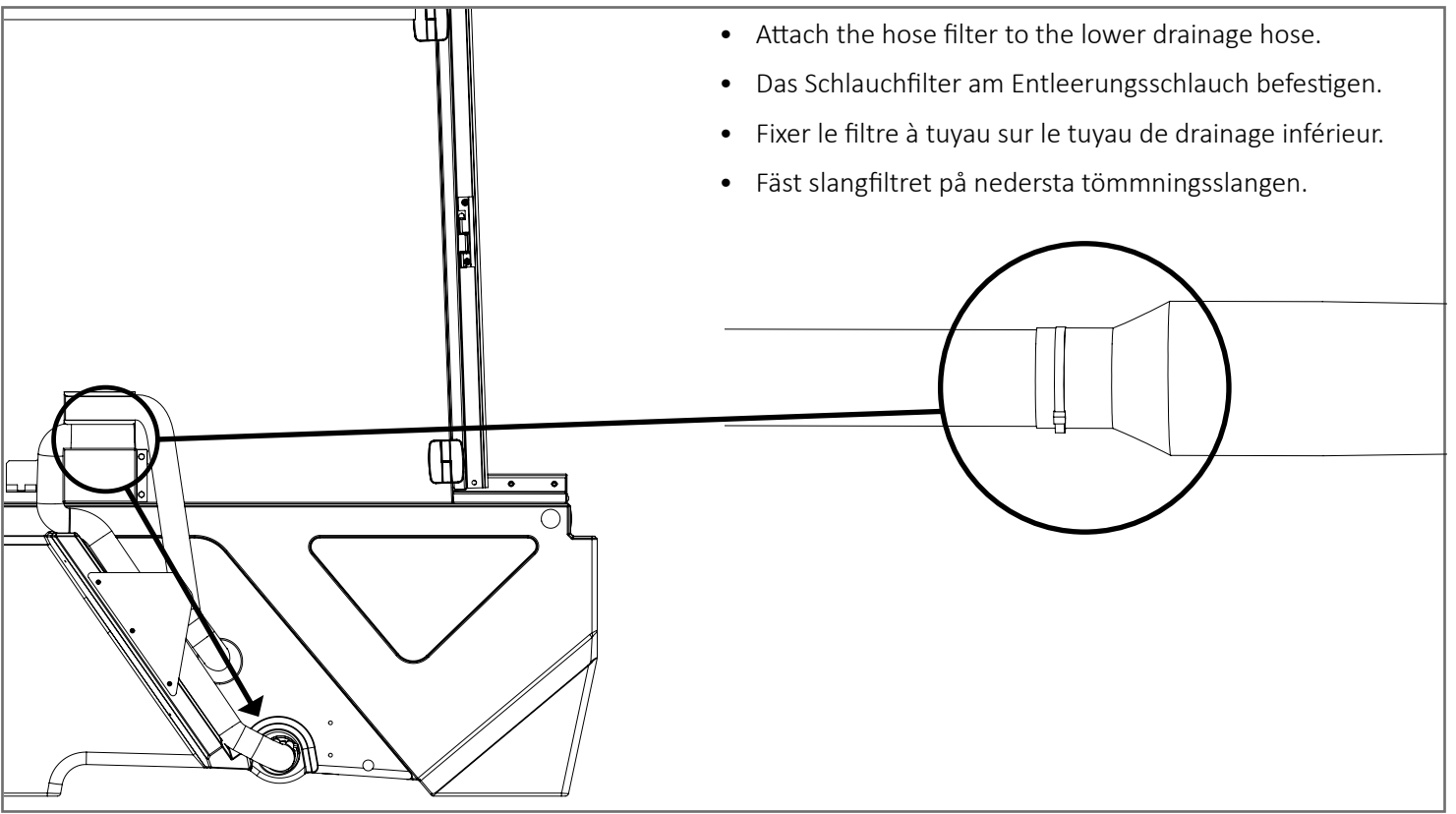

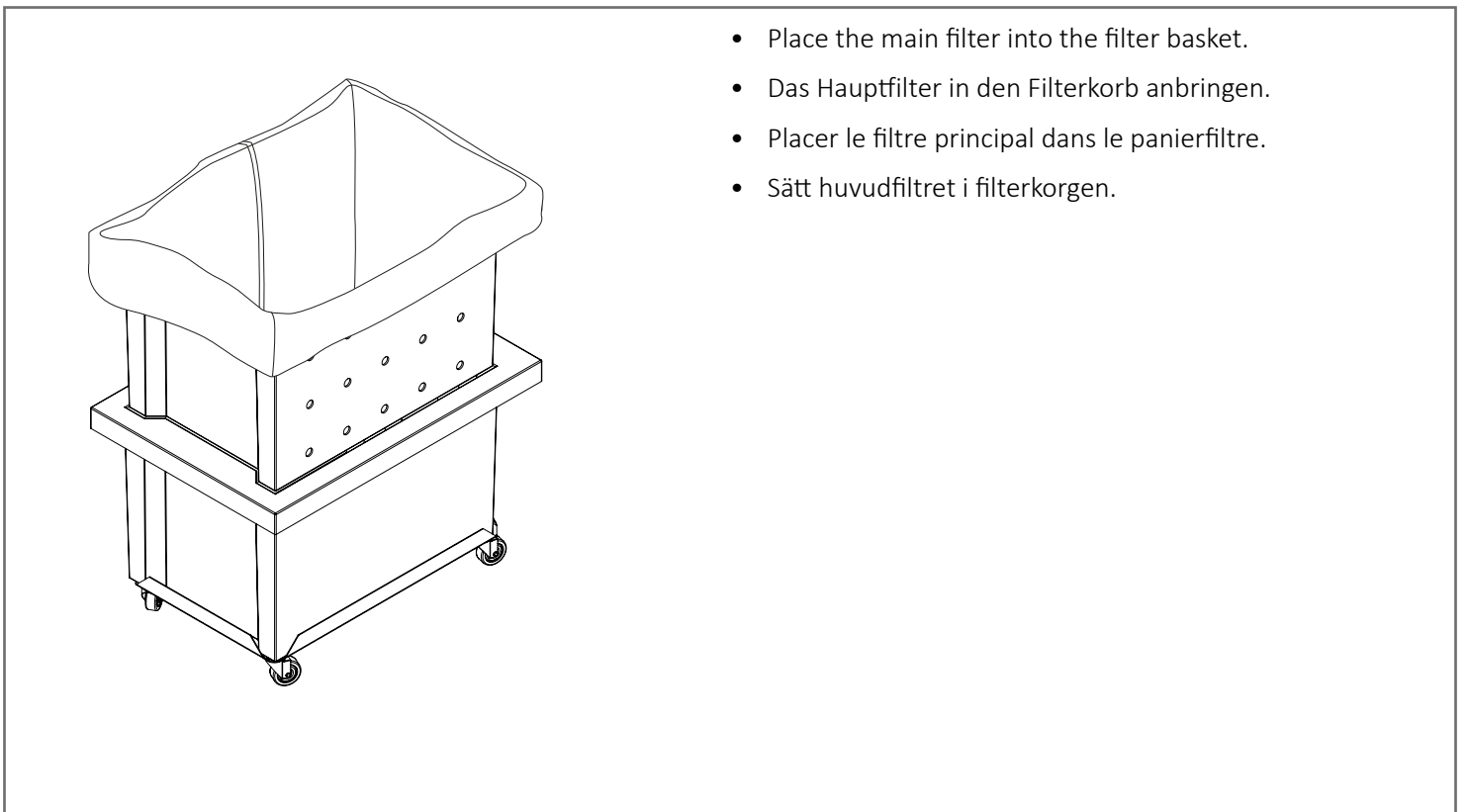
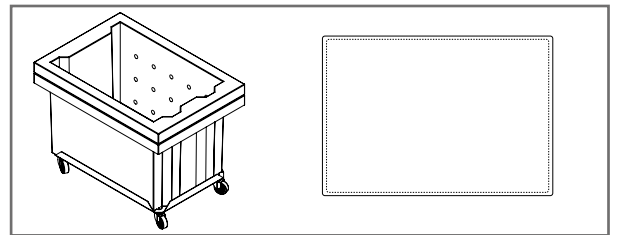
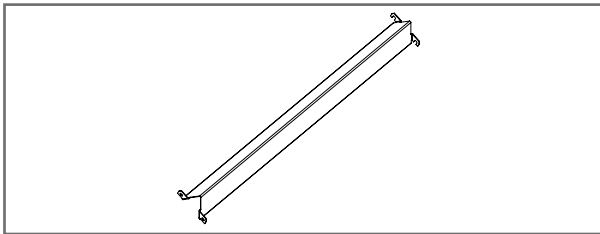
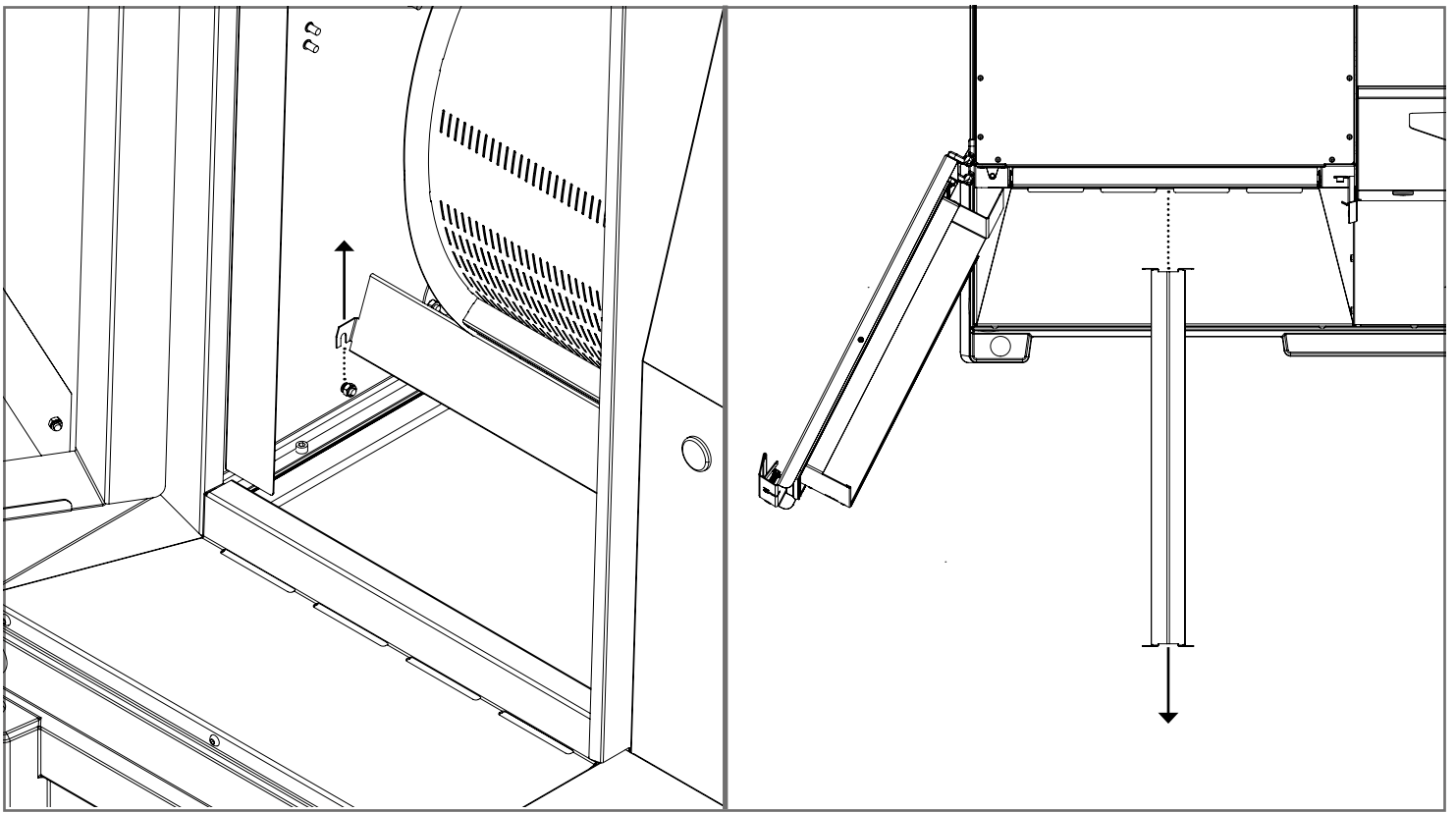

- Place the main filter into the filter basket.
- Das Hauptfilter in den Filterkorb anbringen.
- Placer le filtre principal dans le panierfiltre.
- Sätt huvudfiltret i filterkorgen.

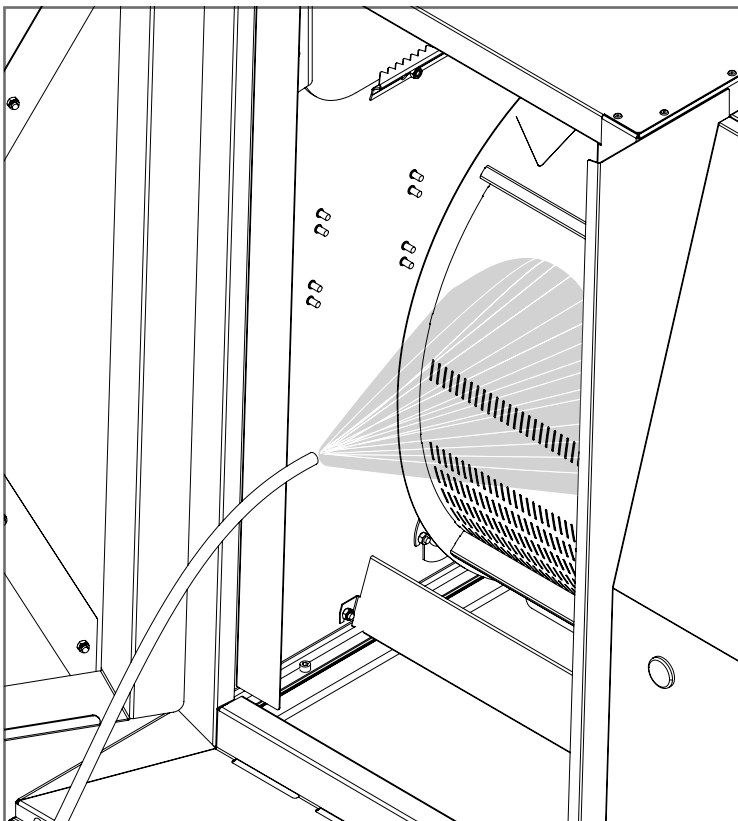
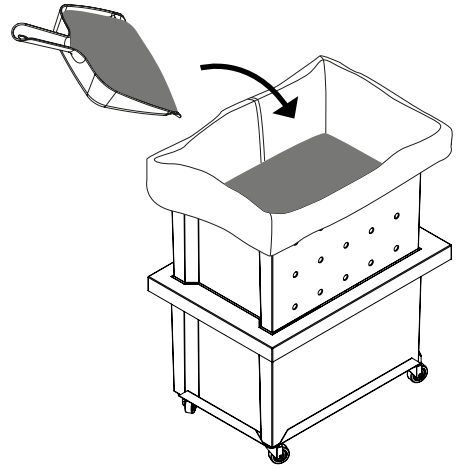
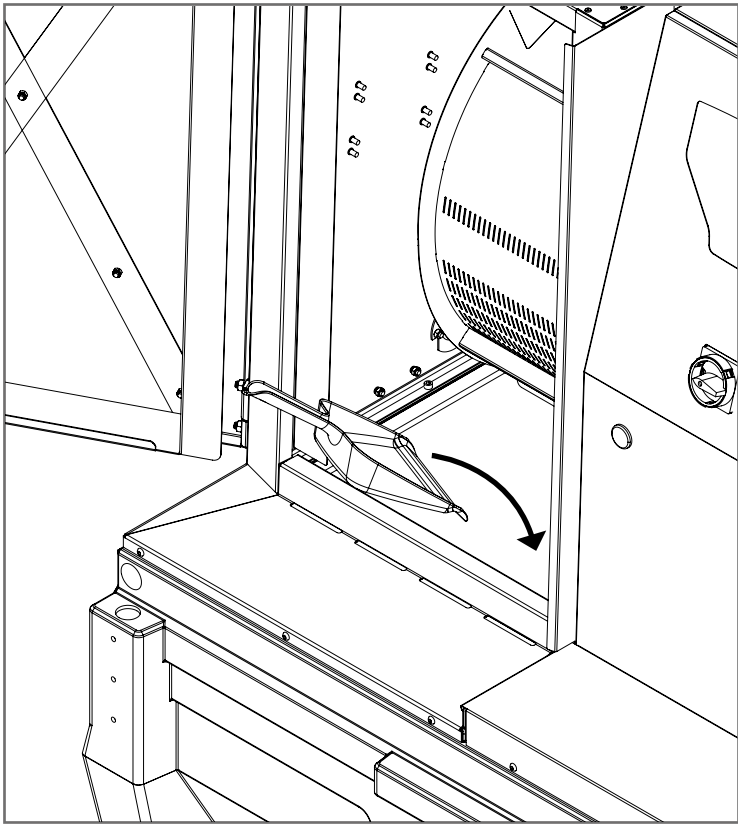

- Rinse the granules and inside of the machine with fresh water.
- Das Granulat und die Innenseite der Maschine mit Frischenwasser abspülen.
- Rincer les granules et à l'interno della macchina con acqua fresca.
- Rengör maskin och granulat med rent vatten.

- Remove the hose filter from the hose. Put the hose filter into the main filter.
- Das filter vom Entleerungsschlauch entfernen und in das Hauptfilter legen.
- Retirez le filtre du tuyau. Mettez le filtre du tuyau dan le filtre principal.
- Ta bort slangfiltret från römmningsslangen och lägg det i huvudfiltret.

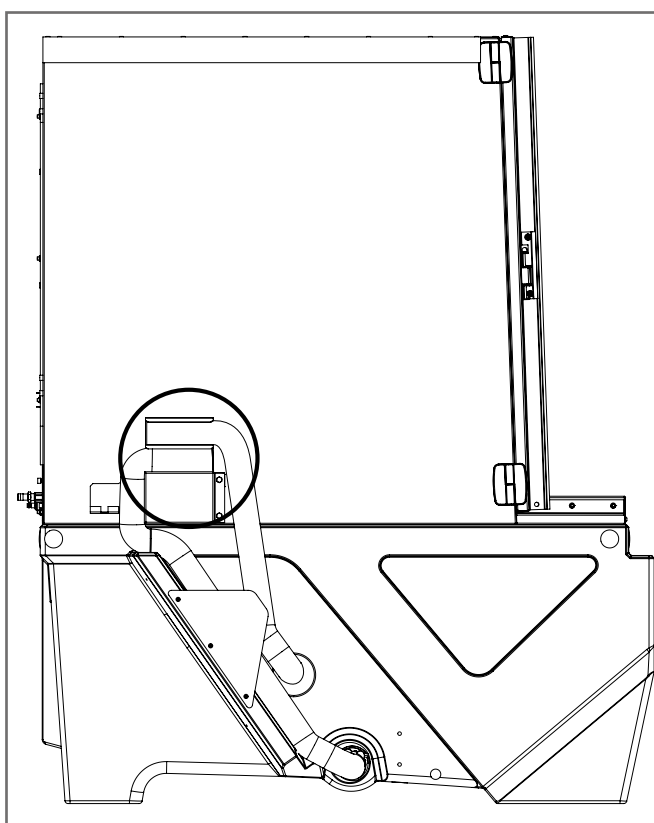
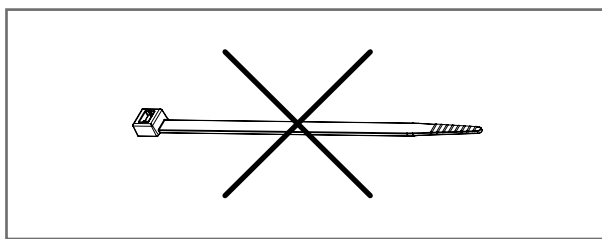
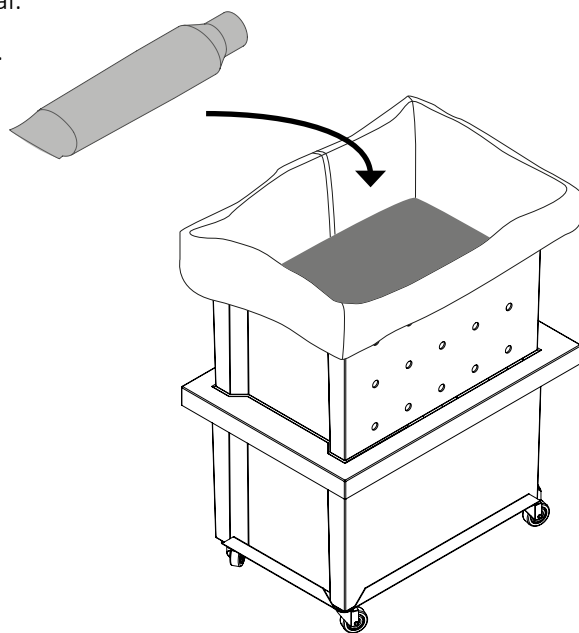
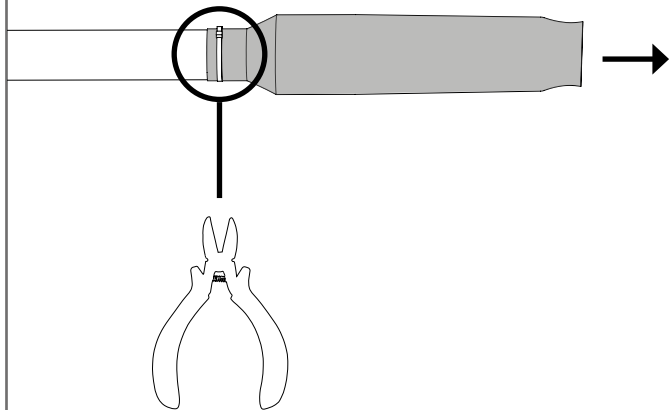

- Hang up the drainage hoses.
- Die Entwässerungsrohre aufhängen.
- Accrochez les tuyaux de drainage.
- Häng tillbaka tömningsslangarna.

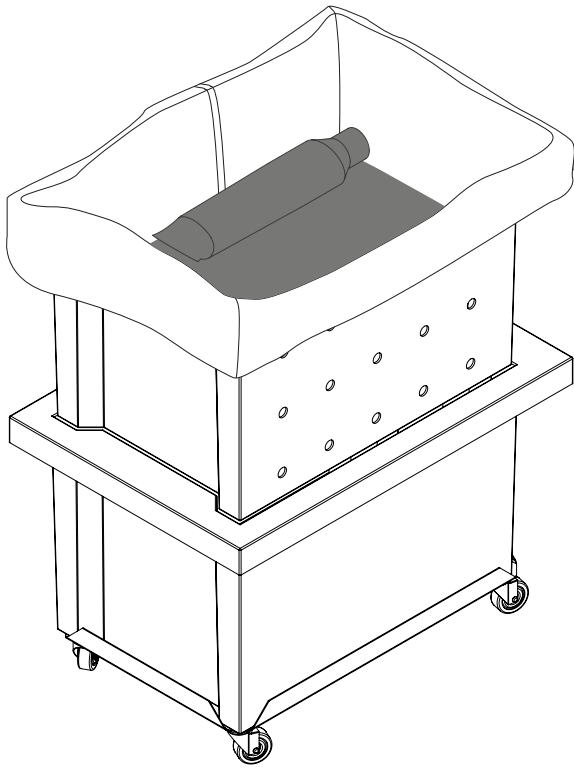

- Let the filter drip until the next water change. The filter can be emptied of the sludge and be reused. The sludge is to be handled as hazardous waste. The water, which is collected into the bottom container, can be emptied into the sewer.
- Das Filter bis zum nächsten Wasserwechsel ablaufen lassen. Das Filter kann entleert werden und wieder verwendet werden. Der Schlamm im Filter soll als Sonderabfall entsorgt werden. Das abgelaufene Wasser, das in den unteren Behälter kommt, kann in den Abfluss gegossen werden.
- Laissez égoutter le filtre jusqu'au prochain changement d'eau. Le filtre peut être vidé et réutilisé. La boue doit être traitée comme un déchet dangereux. L'eau, qui est recueillie dans le récipient de fond, peut être vidée à l'égout.
- Låt filtret stå och droppa av sig till nästa vattenbyte. Filtret kan tömmas och återanvändas. Slammet i filtret skall tas om hand som miljöfarligt avfall. Vattnet som droppat ner i undre kärlet kan tömmas ut i avloppet.



Hedson Technologies AB
Hammarvägen 4
232 37 Arlöv, Sweden
Phone + 46 40 534200
Fax + 46 40 432901
www.hedson.se