

IRT POWERCURE

Installation Manual

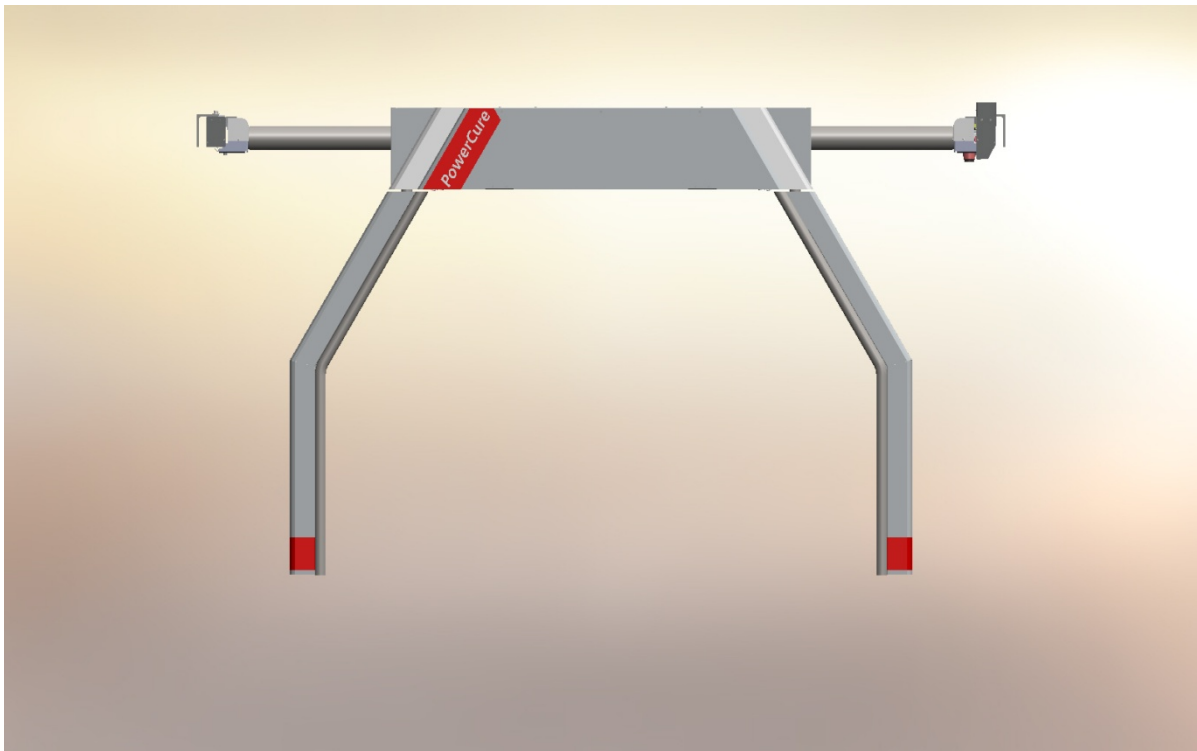

Content

IRT PowerCure	1
Content	2
1 Introduction	4
2 Layout/naming of components	4
3 Dimensions and weights	4
4 Before you begin	4
4.1 Tools for installation.....	5
4.2 Storage.....	5
5 The content of delivery.....	5
5.1 In the smaller box.....	5
5.2 In the bigger box	5
6 Mechanical installation	6
6.1 Prepare the installation site.....	6
6.2 Installing of wall brackets for the side rails.....	7
6.3 Joining of rails	8
6.3.1 <i>Joining of bus bar inside current carrying side rail</i>	8
6.3.2 <i>Joining of aluminium rail</i>	8
6.3.3 <i>Installing labyrinth seal</i>	9
6.4 Arch installation.....	10
6.4.1 <i>Installing the top section</i>	10
6.4.2 <i>Installing the wings of the PowerCure</i>	11
6.4.3 <i>Test smoothness of ride</i>	12
6.4.4 <i>Adjust the drive motor</i>	12
6.5 Remove the transportation protection on lamps and mount protection grids	13
7 Electrical installation	14
7.1 Operator's Panel	14
7.2 Surveillance System	14
7.2.1 <i>Overview</i>	14
7.2.2 <i>Installation of Monitoring Unit</i>	14
7.2.3 <i>Mounting the Differential Air Pressure Switch</i>	15
7.2.4 <i>Mounting of solenoid valves for pressurized air</i>	15
7.2.5 <i>Mounting of the thermostat for booth arch parking air temperature</i>	15
7.3 Power to the Side rail.....	20
7.4 Power supply from the side rail to the MCB:s.....	20
7.5 Connecting the wing to the top section	21
7.6 Check the functionality of the sensors for the PowerCure Wings.....	22

7.7 Adjust the parking sensors on the side rails23

7.8 Remount all cover plates.....23

7.9 Mount and adjust roller door limit switches parking garage for arch.....24

7.10Emergency stop and entry door switches25

8 Operator panel settings at installation27

8.1 Accessing the settings area27

8.2 Entering the parameter settings.....27

8.3 Setting of Floor level (height reading).....27

8.4 Setting of max travel27

8.5 Setting of ventilation period27

8.6 Allow turn in parking booth27

8.7 Switch arrows.....27

8.8 Language selection.....27

APPENDIX28

1 Introduction

This manual is intended to aid the installation of IRT PowerCure. Installation should only be carried out by qualified service personnel, who shall be educated on the IRT products. Although every effort has been made to ensure that the following information is accurate, it is only intended to help the installation personnel rather than direct them in their every step.

Warnings

This equipment uses high voltage!

Check that the supply is disconnected before performing any installation work.

2 Layout/naming of components

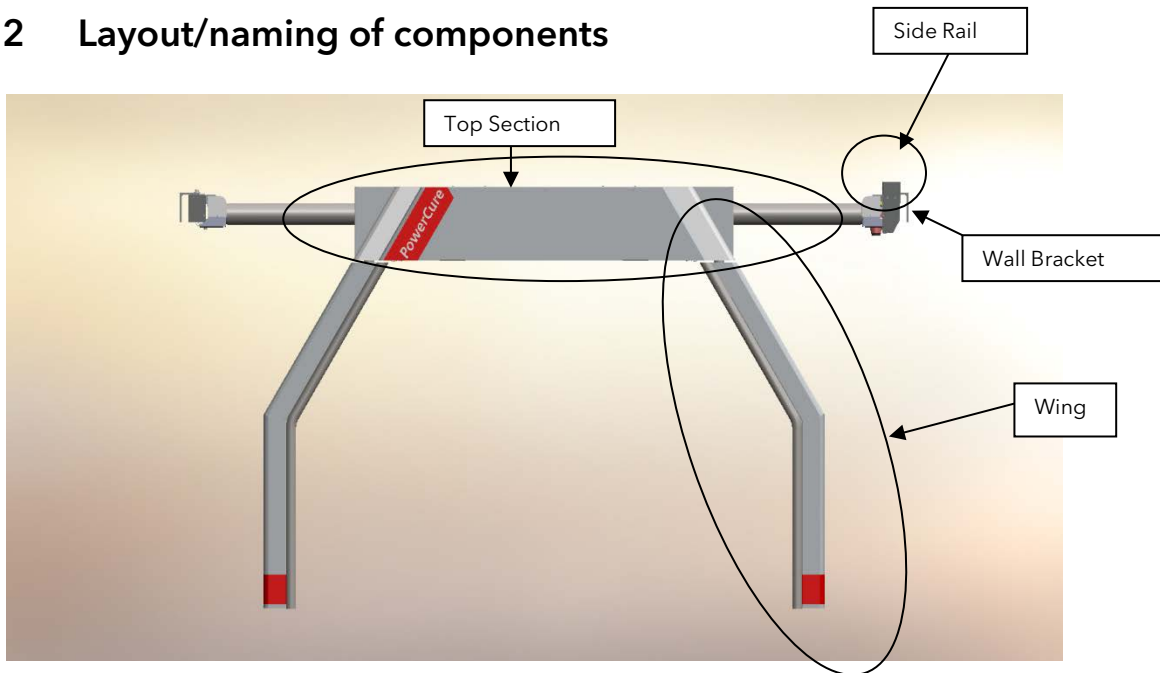

3 Dimensions and weights

Name Weight approximately

Top Section	185 kg
Wing (each)	50 kg

SIDE RAILS

Rail without power supply	5 kg/m
Rail with power supply	7 kg/m

Extension kit (optional)	7 kg x 2
Garage (optional)	30kg

4 Before you begin

Read through the whole of the instruction before starting the installation. In this way you will save time and avoid unnecessary additional work. Many jobs must be performed by two persons, while some tasks require three persons. If this instruction is adhered to, the installation of the entire installation will take approx. 2 days to carry out. Use protective gloves when unpacking and assembling the PowerCure.

All electric installations must be performed by an authorized electrician! Disconnect the inlet power to the whole system before any further step in this manual is made!

The PowerCure equipment is designed to withstand temperatures up to 70°C. (Ambient temperature during operation shall be 40°C max.) Please make sure the booth temperature limiter is adjusted accordingly.

4.1 Tools for installation

The following tools are needed for the installation:

Tool	Size	Qty
Socket wrench kit	metric	1
Box-end wrench	10 mm	1
Box-end wrench	13 mm	2
Box-end wrench	18 mm	2
Screwdriver Philips	2	1
Screwdriver flat	2, 3, 4, 6 mm	1 ea
Allen key	4, 5, 8 mm	1 ea
Hacksaw		1
Pointed pliers		1
Cutting pliers		1
Multimeter		1
Measuring tape	(Booth width)	1
Level instrument (laser)	(Booth length)	1
Ladder (four-legged)	Fitted for 2,5m working height	1
Protective Gloves		2 pairs
Forklift	>350 kg	1

4.2 Storage

The PowerCure should be stored inside.

5 The content of delivery

5.1 In the smaller box

- Side rails cut to order
- Wall Brackets
- Cable chain

5.2 In the bigger box

- Arch top section
- Arch wings
- Surveillance unit
- Operator's panel (20 m cable)
- Box with fitting material

Cables needed for the installation are not included.
See separate cable list Appendix III (Single box), Appendix IV (Double box).

6 Mechanical installation

6.1 Prepare the installation site

If the PowerCure shall be parked behind a roller door:

Prepare an opening for the rails in the wall between the spray area and the parking area (see picture).

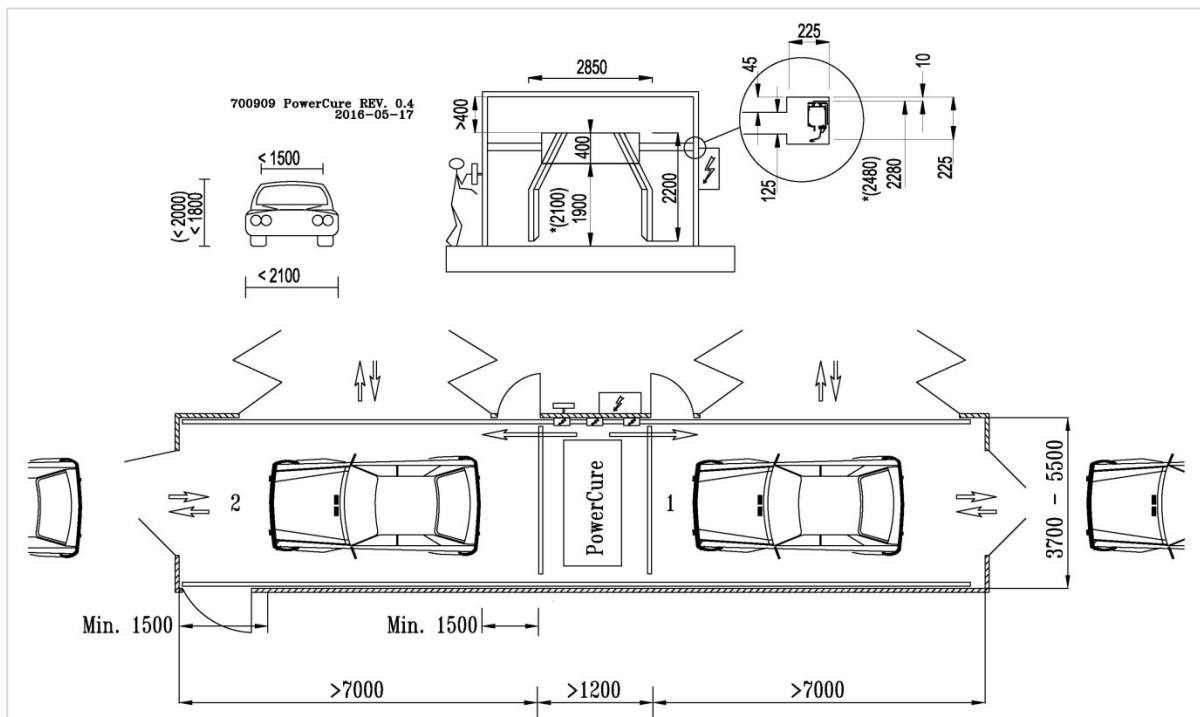
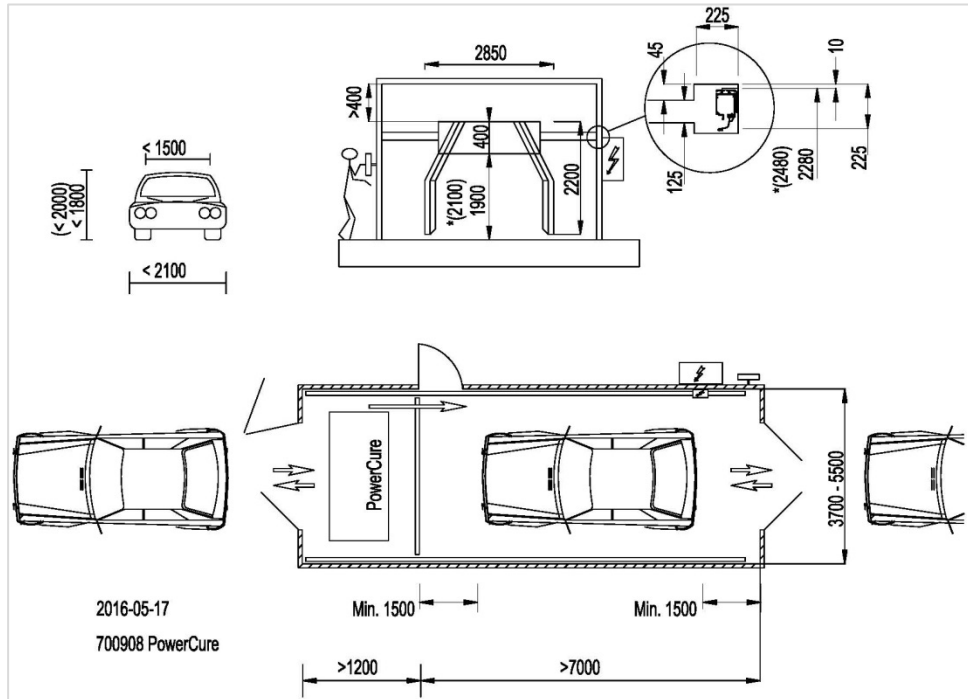

*Top side rail

6.2 Installing of wall brackets for the side rails

PLEASE NOTE!

- As the profile is not symmetrical, the side rail must be pointed in towards the work area in the manner illustrated in the figure.
- Side rail with power (integrated power supply) should be mounted on the side where incoming power is routed.

The number of Wall Brackets for the side rails is one for each 1.5 m - rounded upwards.

Aim at suspension points every 1.5 m. Maximum distance between 2 suspension points is 2.0 m.

PLEASE NOTE!

Too long distance between the brackets can cause joints of side rails to open up and cause drive and positioning to malfunction.

The Brackets are mounted at a height of 2280mm (2480mm if the option side extension is chosen).

PLEASE NOTE!

- The measurement is between the floor and the lower side of the horizontal part of the wall bracket, please see picture.

Available clamp length for the suspension bolts is up to 10 mm. Check the final assembly of the longitudinal rails making sure they are parallel ± 1 mm and maximum a horizontal error of ± 2 mm. Laser level instrument is required.

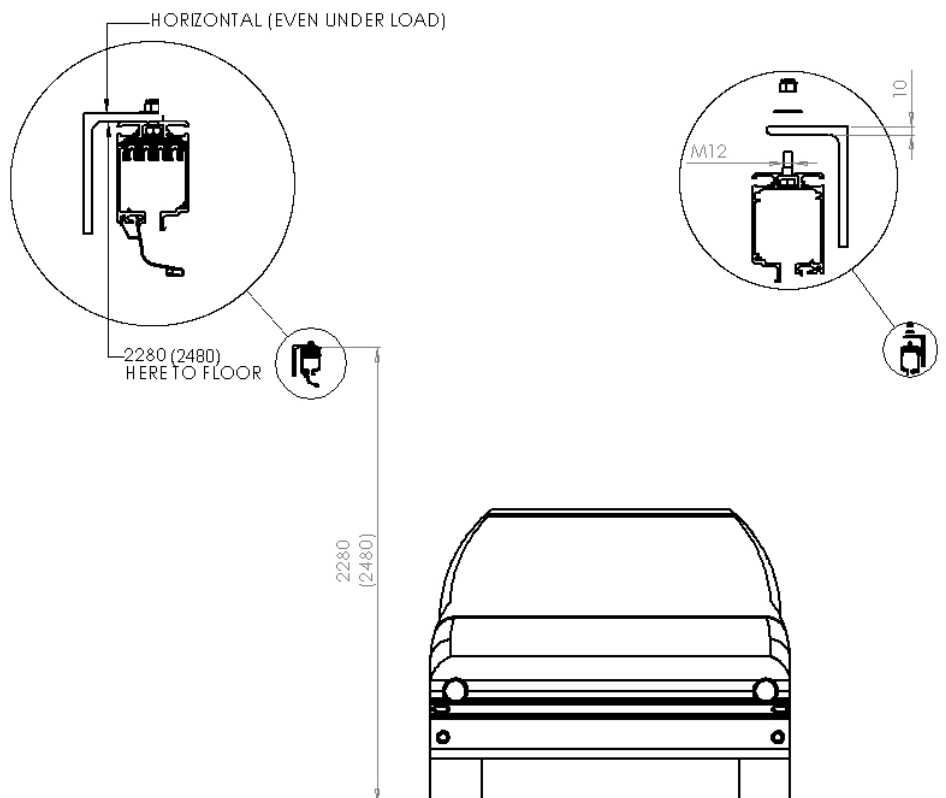

6.3 Joining of rails

Joining of side rails is done, when they are mounted to the brackets on the wall.

6.3.1 Joining of bus bar inside current carrying side rail

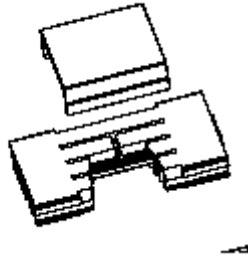

Check the copper pins used to join the electric bus bars. Check that the insulation plate over the electric rails provides the copper pins with complete protection. Carefully press the bus bars together.

6.3.2 Joining of aluminium rail

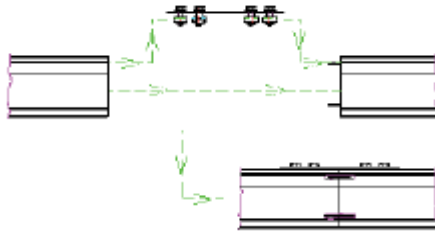

When the rails have been carefully pressed together as per the figure and an electric connection has been secured with the copper pins, the mechanical connection is stabilized with the metal plates on the top of the rail. Slide one metal plate into the groove on the aluminum profile before pressing the rails together. Then secure the connection by tightening the screws.

6.3.3 Installing labyrinth seal

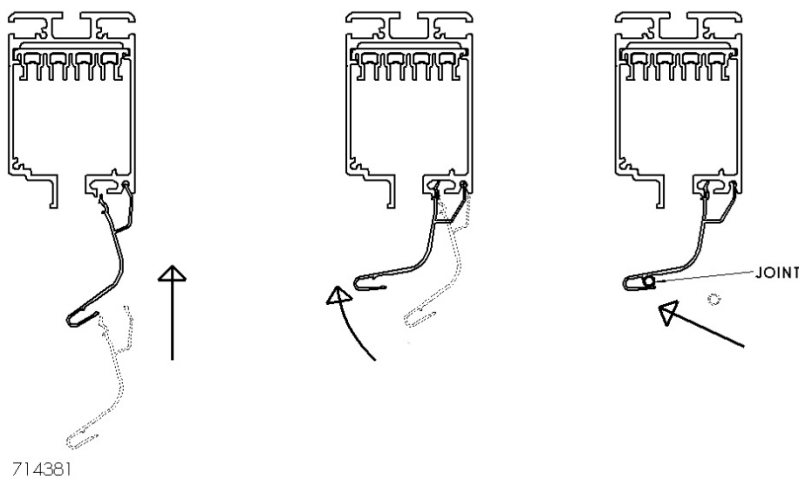

Mount the labyrinth seal as per figure in order to provide the conductor rail with optimum protection.

Cut the seal so that it covers the entire length of the rail.

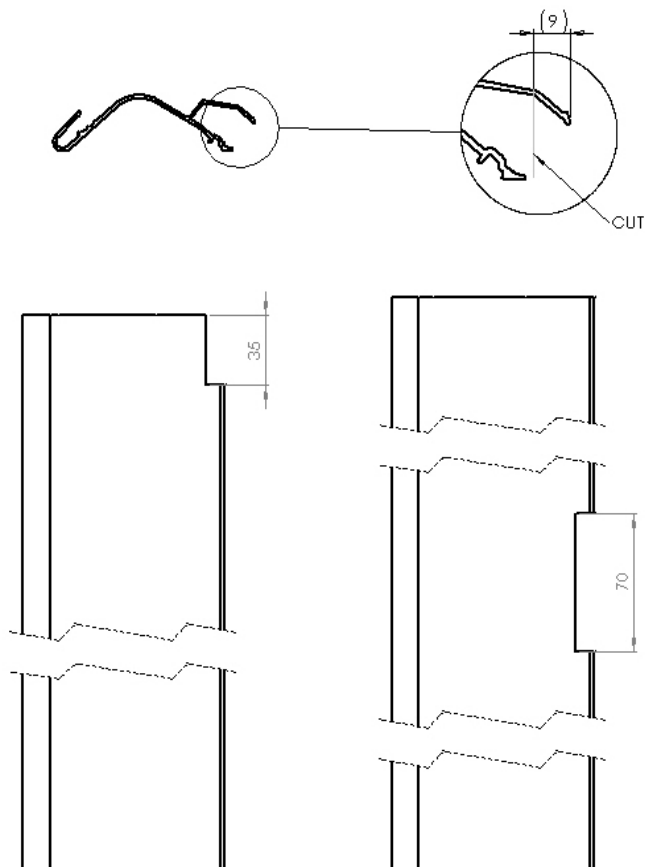

A cutout for side rails pin is made with hacksaw. Make three cuts and then waggel using pliers to loosen the part.

6.4 Arch installation

6.4.1 Installing the top section

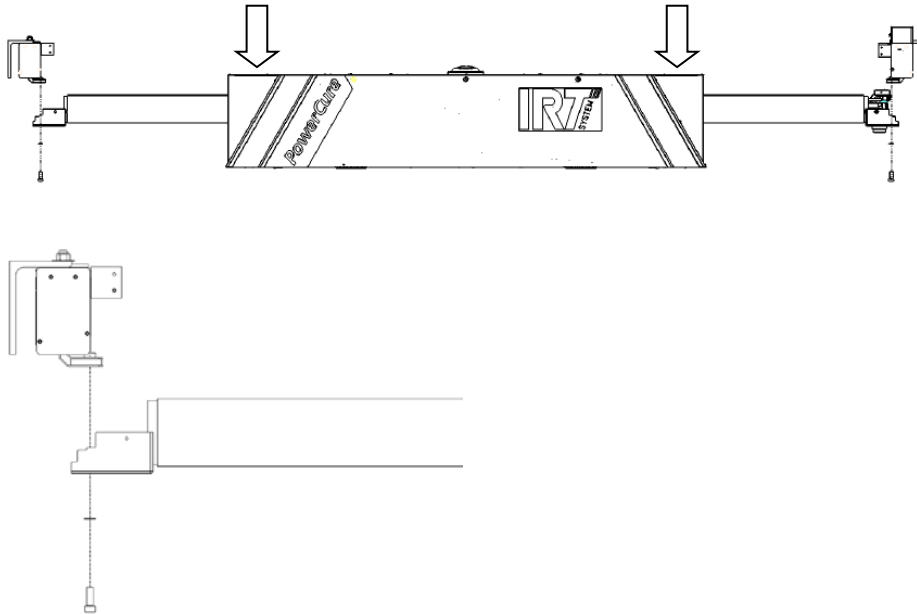

The top section is delivered assembled and fits directly on the carriages of the side rails. Note the marking "P" pointing out parking garage direction.

Remove the covers over the wing turning motors (marked with arrows above).

Remove also the covers at both ends of the arms.

Make sure that the center of the PowerCure aligns with the center of the booth.

PLEASE NOTE!

- At the arm ends, sensors are mounted. Please handle the sensitive mechanical and electrical parts with great care.
- Make sure not to damage the power cables from the side rail trolley during this assembly.
- Make sure that the height sensor in the top section is at the side closest to the car when the arch is in its parked position. Please take care that the cables are routed without risk of damage.

Lift the top section to the correct height. Extend the arms to reach the side rail carriages.

Mount the 4 screws with washer on each side. Check that the top section is perpendicular to the side rails.

Tighten the screws. (See 6.1.)

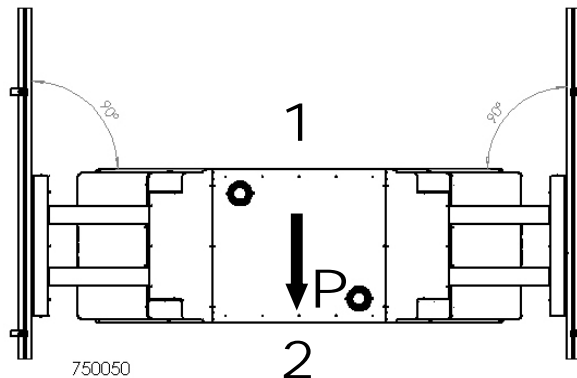

6.4.2 Installing the wings of the PowerCure

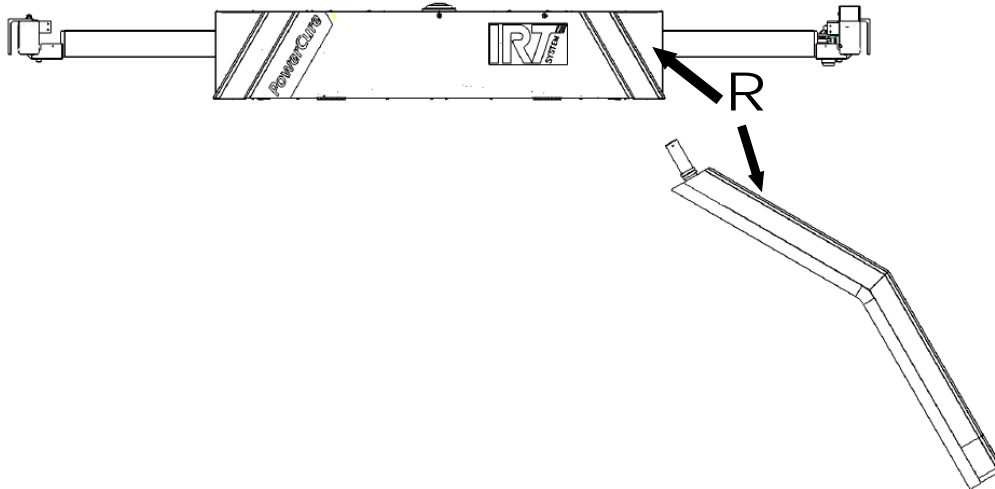

The wings are marked on the packaging "R" and "L" for right and left installation.

Ensure that the shafts of the wings and bearings (lower and upper) in the top section are not damaged.

Push the cabling and the side's shaft up through the bearings (moving the lower bearing to the shaft eases the mounting).

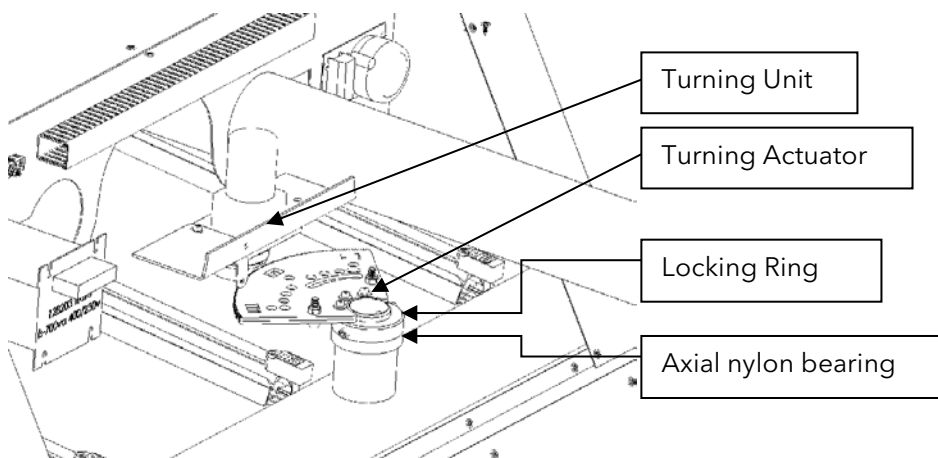

Secure the PowerCure side from falling down by attaching the nylon bearing and the upper ring¹ by locking it with the **2 screws** (one can be seen in the picture above). Be sure to hit the holes in the shaft. Place the turning actuator in position. The correct position is when the index for the center position positions the wings parallel to each other. Tighten the 3 Allen screws.

¹⁾ Due to the risk of the gear sector segment damaging the sensors, it is strongly recommended that the gear sector is mounted after the "locking ring" is in position and secured.

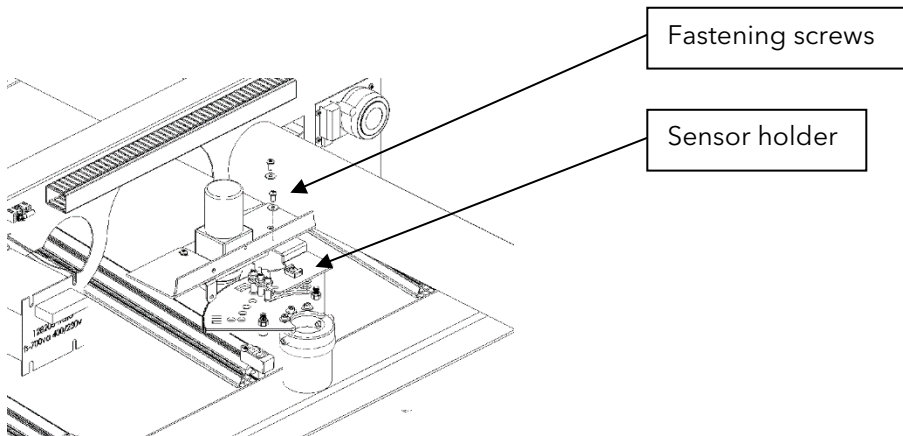

Mount the sensor holder to align sensors with the holes in the turning actuator.

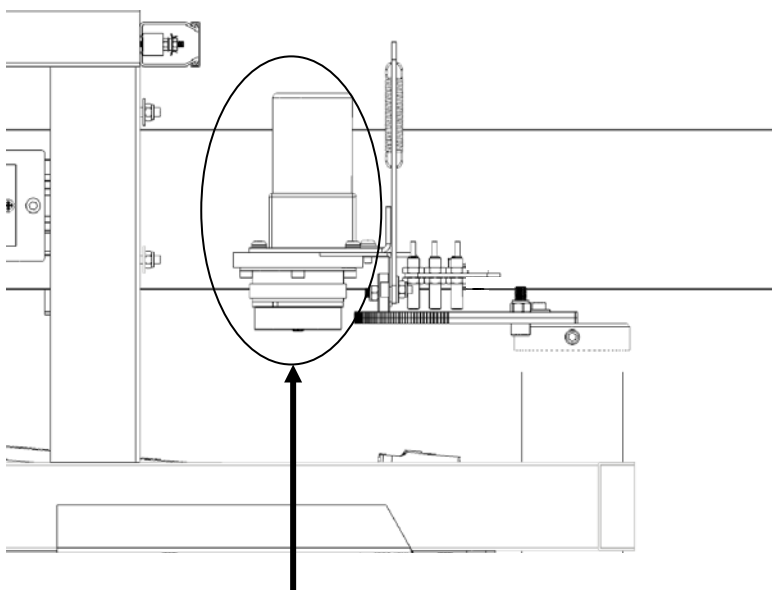

Adjust the Turning actuator by hand to a position where the gear works smoothly in the entire range without significant play in the gear.

6.4.3 Test smoothness of ride

Push the arch by hand from one end of the rail, along the cabin, to the other. The travel shall be smooth and the force needed should be less than 200 N. Observe the parallelism between the rails when performing this test.

If the arch does not travel smooth or a force greater than 200 N is needed the cause must be identified and corrected before proceeding with the installation, check the following:

- Check parallelism between rails and tolerances according to 6.2 again and correct
- Check that the top section is perpendicular to the side rails according to 6.4 correct if necessary.

Adjust the drive motor

Tighten the nut that compresses the spring. After the drive wheel has touched the aluminum profile the nut should be tightened to compress the spring another 10±2mm.

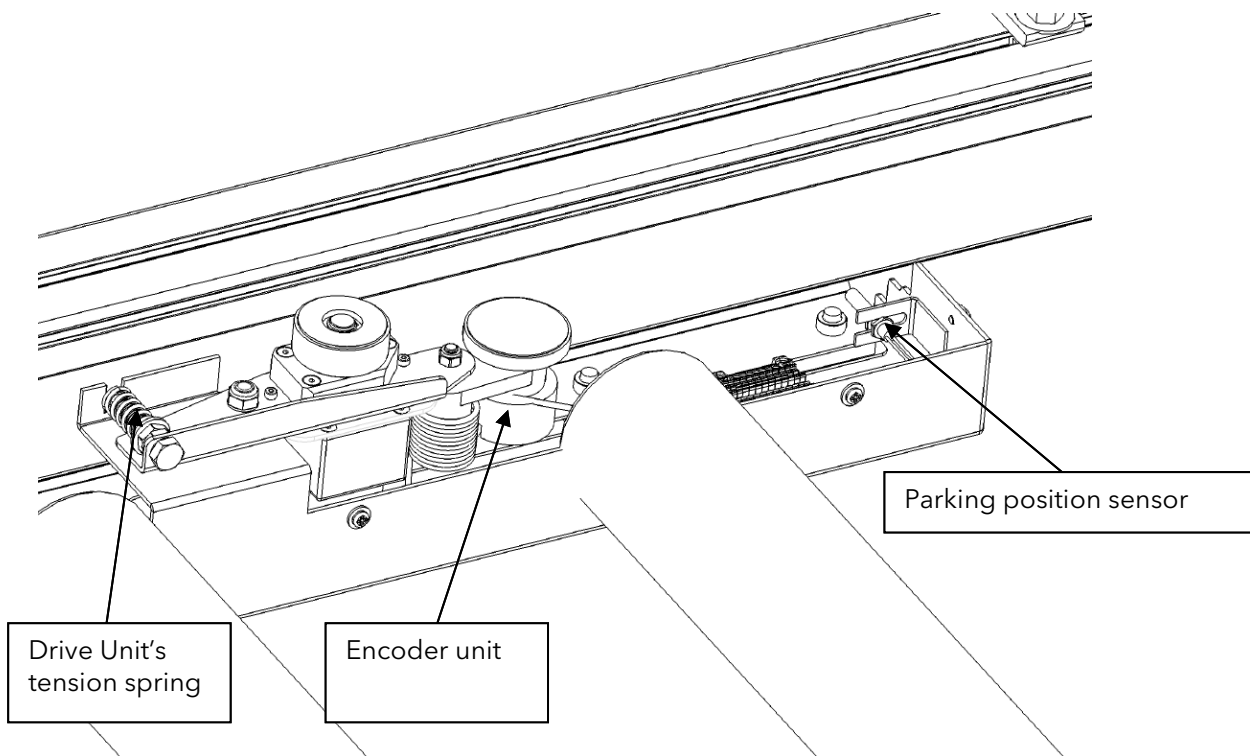

Mount the torsion spring to the encoder unit. Mount the Parking Position Sensor in the fork holder. Put the arch at the park position and glue the magnet on side rail in front of the sensor

Adjust the Parking Position Sensor. Distance between sensor and the magnet should be 5 ± 1 mm

6.5 Remove the transportation protection on lamps and mount protection grids

Carefully remove the tape that supports the emitter tubes taking care not to touch the golden reflector surface.

Slide the grids in place in front of each reflector and tighten the screws to secure them.

7 Electrical installation

The electric installation must be carried out according to the enclosed documentation by a qualified electrician. See separate terminal connection diagram, Appendix V (Single box) Appendix VI (Double box).

7.1 Operator's Panel

Make sure that the Operator's Panel (HMI) is mounted where a clear view of the spray booth's inside (and all positions of the PowerCure) can be obtained.

In the scope of delivery are two 20 meter long cables between the Operator's Panel and the Surveillance unit.

7.2 Surveillance System

7.2.1 Overview

The purpose of this system is to stop electricity into the booth when it is used for spray painting. This is obtained by an interlock between the pressurized air to the spray gun and the electrical power to the PowerCure. In addition, the control surveys the efficiency of the booth ventilation (Exhaust air fan).

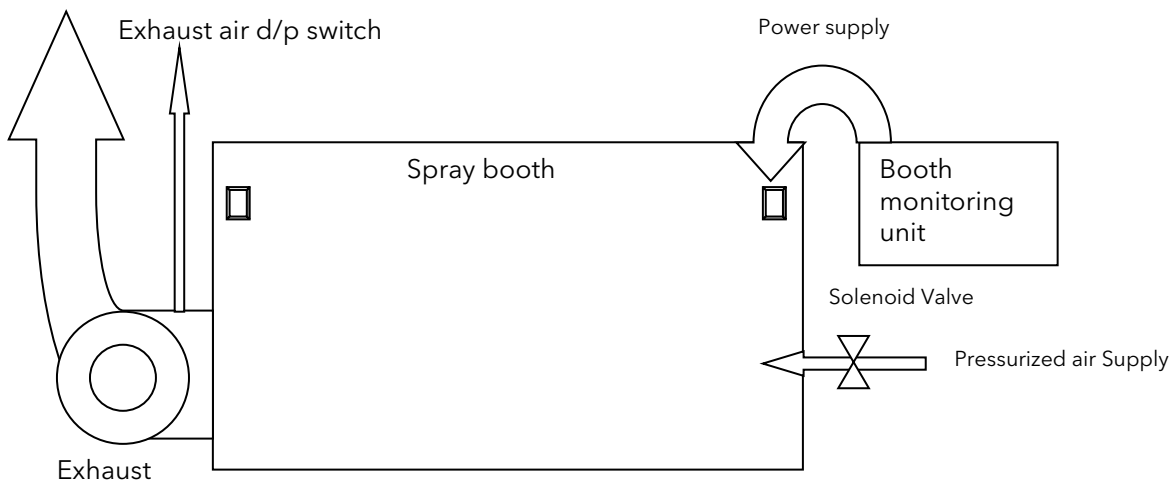

7.2.2 Installation of Monitoring Unit

Place the monitoring unit outside the box on the routing for the power supply, so that you can handle the main switch and have reasonable access (for example resetting fuses). **Note:** All components **must** be installed outside the box! Strive to find an ideal compromise between short cabling and optimum positioning for the following:

- PowerCure touch screen (<20meter cabling)
- Solenoid valve to control spray gun air (230 Volt cabling, not supplied)
- Location for the pressure supervision (d/p switch) of the ventilation (24 Volt cabling, not supplied)

Mount the cabinet with 4 screws (not supplied) (holes for these screws has diameter of 8,5mm).

PLEASE NOTE: The PowerCure's internet connection is located in the monitoring unit.

7.2.3 Mounting the Differential Air Pressure Switch

The purpose with the differential air pressure switch is to detect that the ventilation is working. By measuring the difference between room pressure and **suction side of the exhaust fan, as close as possible to the booth**, the ventilation pressure is verified.

Note!

If a leakage at the suction side occurs, this will be detected if the Pitot tube is located close to the booth (that is before the leakage). For the same reason it is not advisable to measure at the pressure side and compare that to ambient air pressure.

Drill a 7-8mm hole for the differential air pressure switch and secure it with 2 screws (supplied by customer) to tighten the flange.

Ensure that the switch is mounted higher than the Pitot tube and that the hose between does drain itself if any water condenses inside.

Connect and route the cabling to the control box (cabling supplied by customer).

The differential pressure switch must be adjusted to ventilation conditions in the actual booth before initial use. To do so, start the booth ventilation with the lowest volume flow allowed according to the booth manufacture. By adjusting the knurled screw (see picture) find the position, where the indicator lamp turns off/on for the actual conditions. From this position turn the knurled screw 1-2 revolutions counter clockwise.

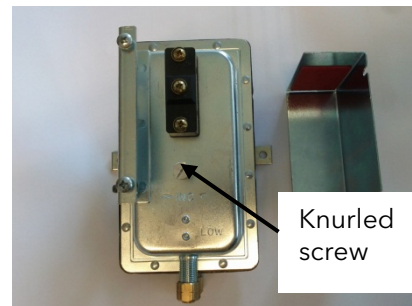

7.2.4 Mounting of solenoid valves for pressurized air

Mount the solenoid valve unit (including pressure switch) as close as possible to the paint spraying gun, outside the area of explosion risk. The closer the safer is the solution. The reason for this is that with less available pressurized air in the system, the less solvent/paint can be released into the booth at the wrong occasion, which is after the solenoid is closed.

Connect and route the cabling to the control box (cabling supplied by customer).

7.2.5 Mounting of the thermostat for booth arch parking air temperature

The purpose with the thermostat switch is to monitor the air temperature inside the booth where the arch is parked.

If the temperature exceeds 50°C, the voltage to the arch will not be switched on. This to protect the equipment.

Mount the box outside the cabin.

Drill a 7 mm hole for the capillary tube through the booth wall and fix it with the two enclosed straps to the inside wall at the arch's park position (suits in 7 mm hole).

Connect and route the cabling to the control box (cabling supplied by customer).

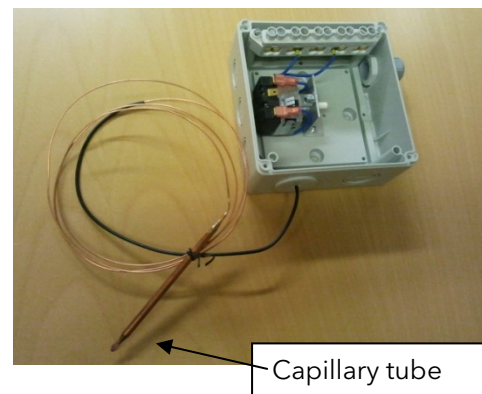

7.2.5.1 Installation of cable chain/ cable for communication to PowerCure

Install one bracket in every joint of the guide rail. Attach the guide rails. Install the cable chain, see illustration, onto the side rail opposite to the power supply. Make sure that the guide rail joints are installed without obstructions so that the cable chain can run smoothly without risk of catching.

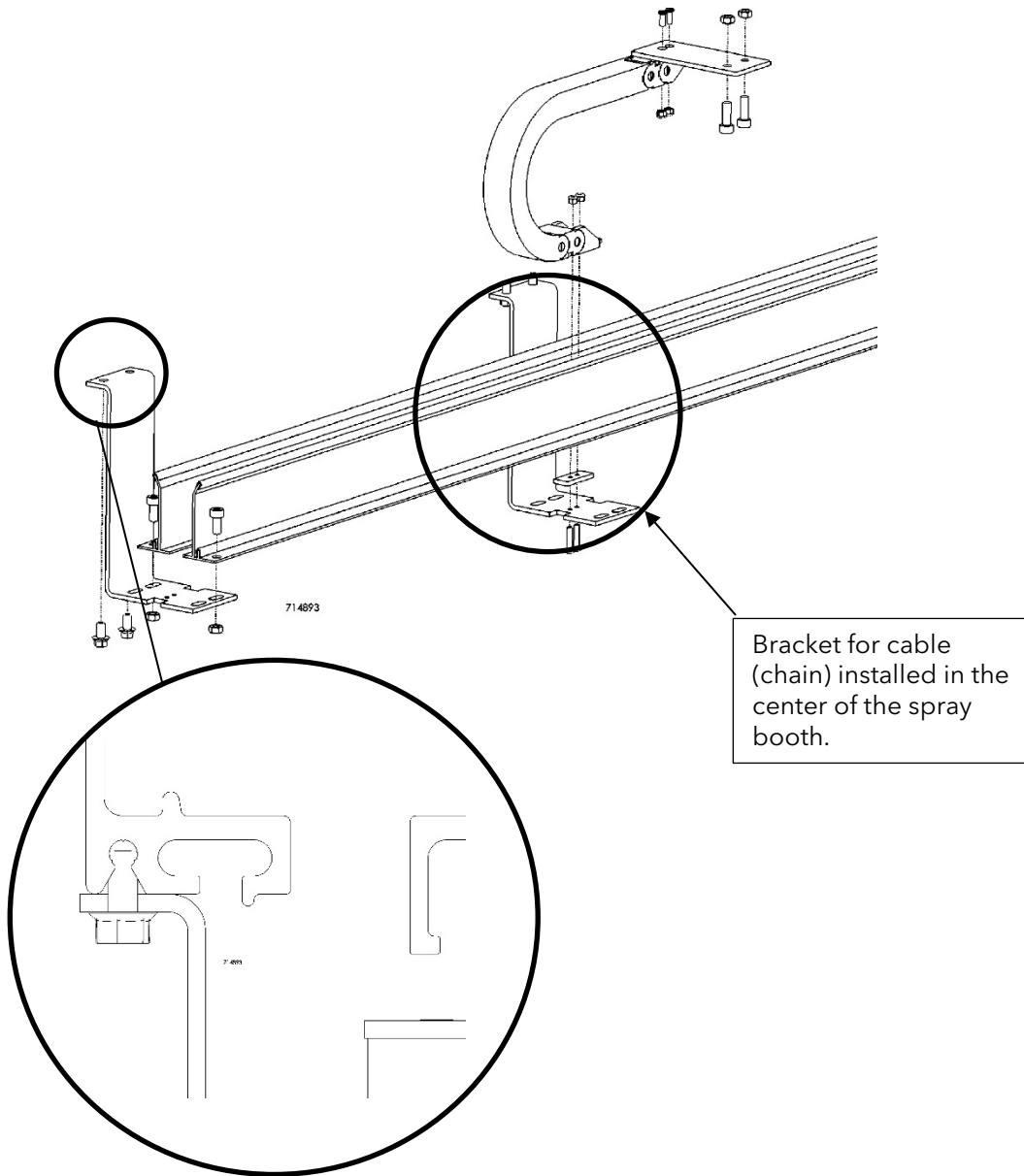

Insert the cable:



Install and insert the cable through the pipe beside the other sensor cables and then in to the top selection:



Connect to the control system in top selection:

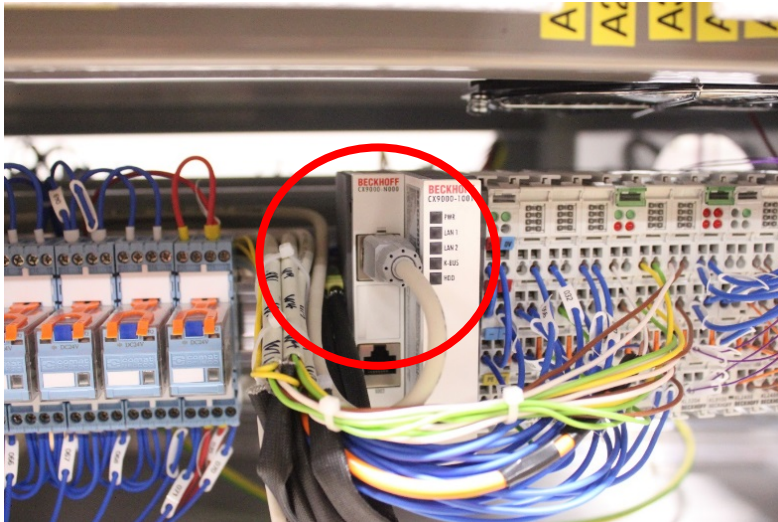

The photo shows the cable chain/cable installed.
From there, install the cable in a suitable manner to the control cabinet.
Avoid parallel positioning next to power cables, due to disturbances.



Install the other part of the cable in the control cabinet.

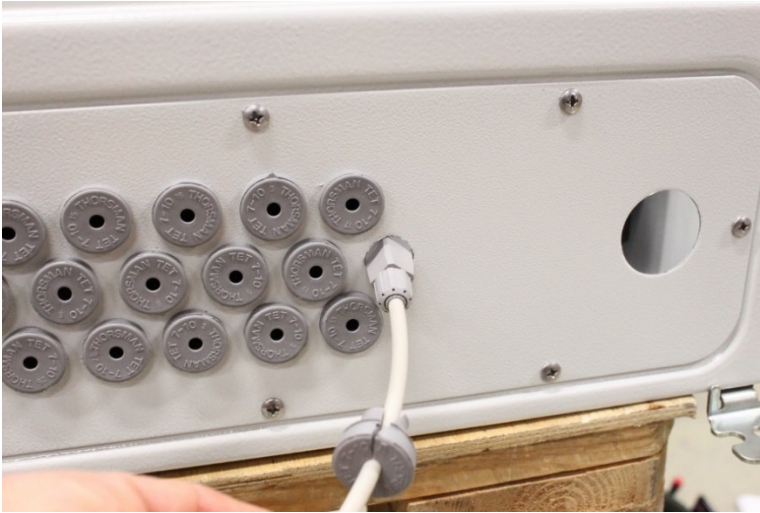

The photo shows the bottom of the control cabinet.
Bottom side of control cabinet, communications cable installed:



Inside the control cabinet, communications cable installed in control system:

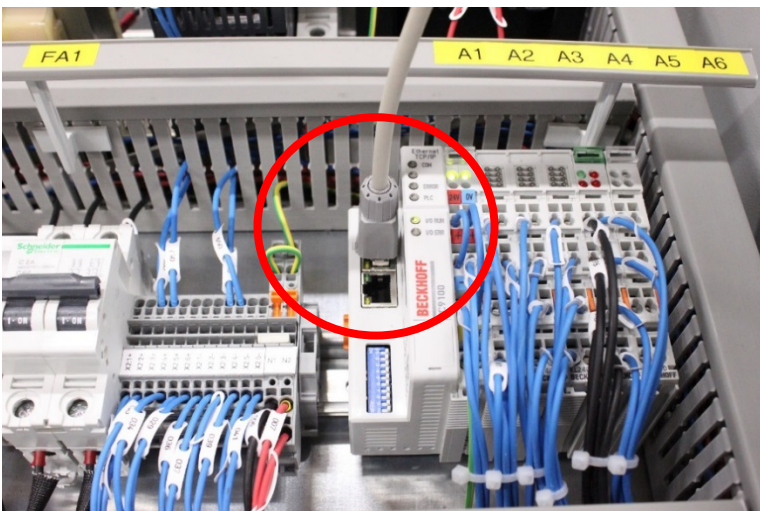

7.3 Power to the Side rail

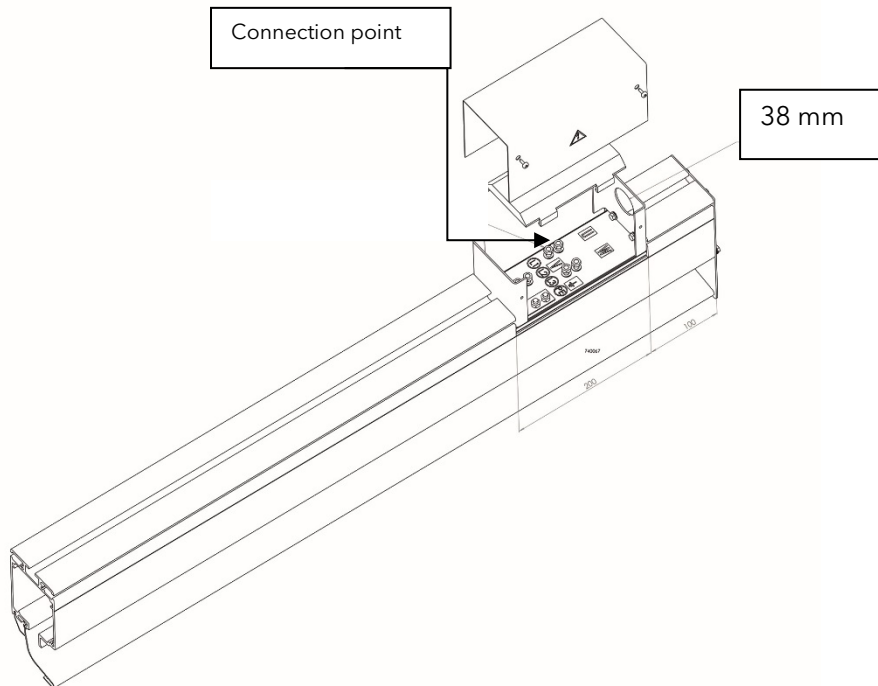

Detach the two screws on the connecting box. Pull the cover plate slightly to the side and then remove it. Connect the supply cable's protective conductor and three live conductors to the connectors on the side rail.

Remount the connection box cover with the two screws.

7.4 Power supply from the side rail to the MCB:s

Open the doors to the electrical compartment of the top section.

Ensure that the markings ("L1", "L2", "L3" and "PE") on the eight conductors from the side rail carriage are secured.

Feed the eight cords from the side rail carriage through the pipe, exiting in the hole at the picture. Check that markings are still in place.

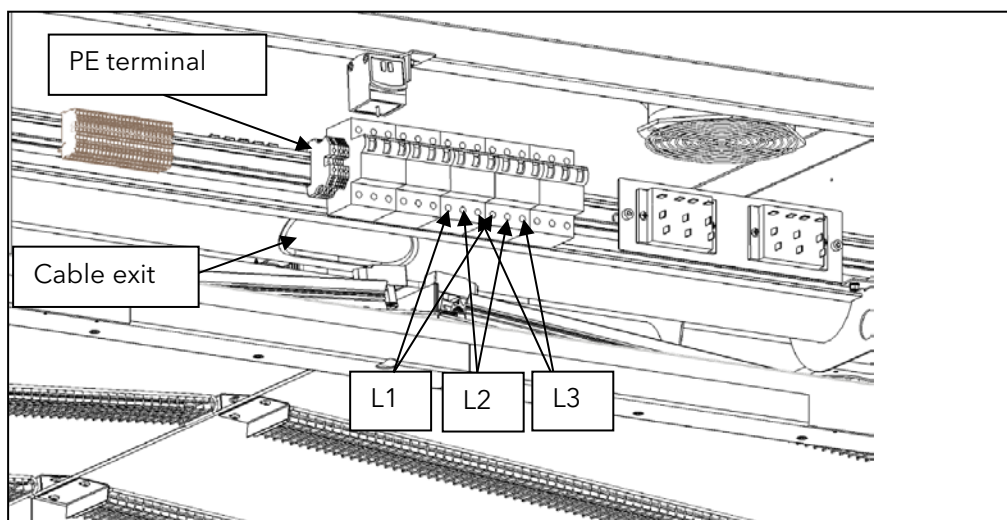

7.6 Check the functionality of the sensors for the PowerCure Wings

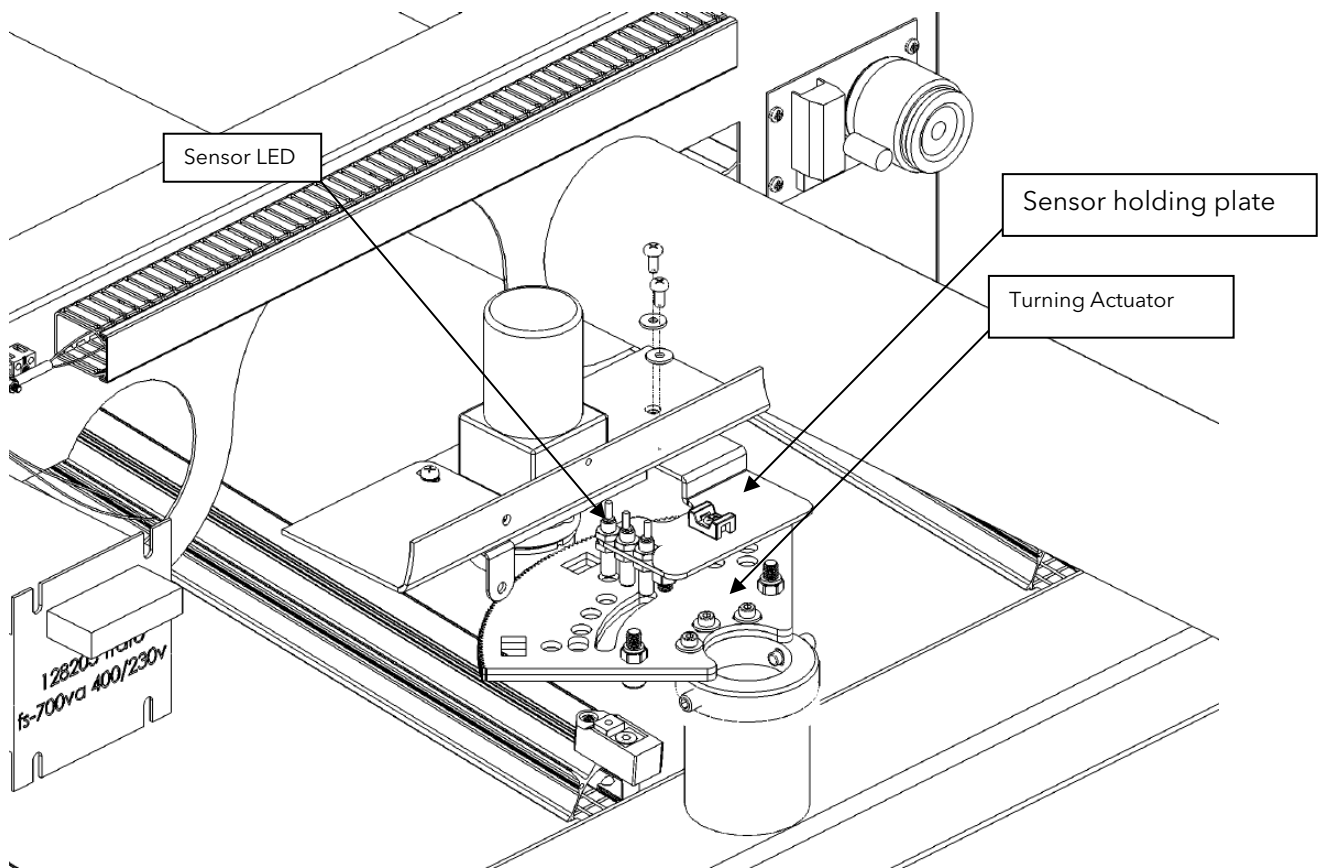

Ensure that the plate holding the sensors is aligned above the different patterns on the turning actuator.

The distance between the sensors and the turning actuator should be $2\text{mm} \pm 1\text{mm}$.

After Powering up the PowerCure, check that the LED's on the sensors are coordinated with the pattern.

7.7 Adjust the parking sensors on the side rails

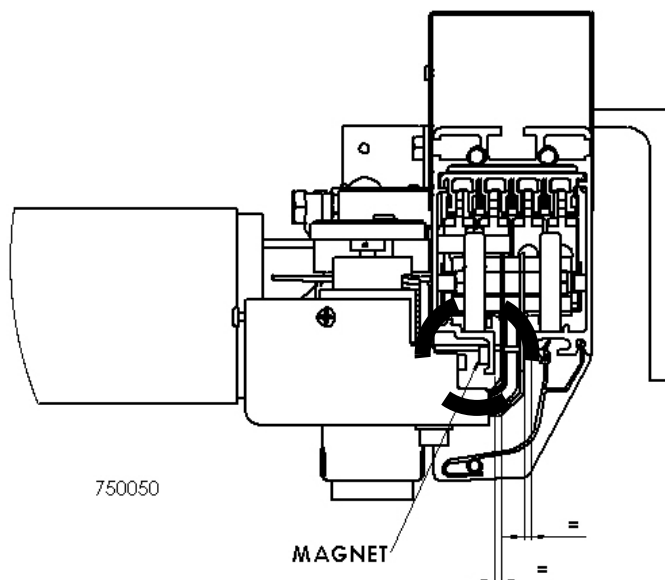
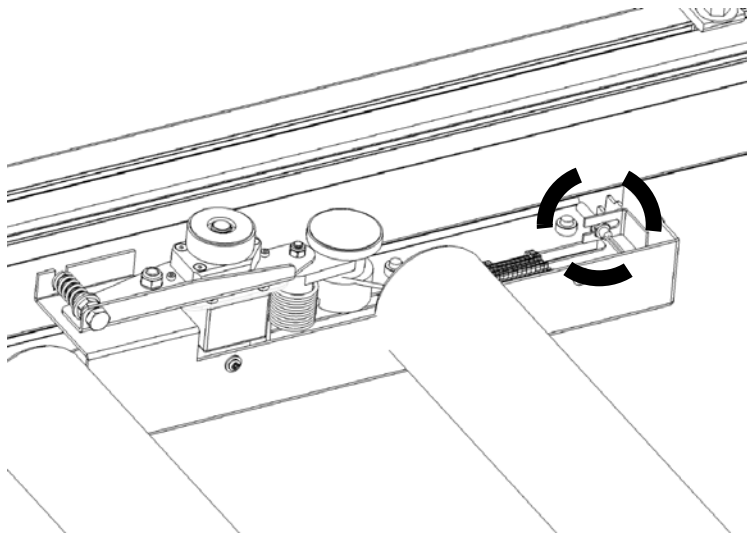

Move the PowerCure to the park position (behind the roller door or at the garage). Place the magnet in front of the Parking Sensor as indicated above. If necessary adjust the distance between the sensor and the magnet to be $5\text{mm} \pm 2\text{mm}$.

Ensure that when the Parking Sensor indicates the parking position, the clearance to the mechanical stop should be greater than 25mm.

- Control that the carriage is centered in the rail as the picture above shows.

7.8 Remount all cover plates.

Mount the covers at the ends of the carrying arms.

Mount the covers over the wing turning motors.

Close the doors at the front and back of the top section.

7.9 Mount and adjust roller door limit switches parking garage for arch

Mount the roller door limit switches as indicated on the image below.

Make sure that the top sensor indicates a fully opened door and that the arch passes under it.

Make sure that the door is fully closed when the bottom sensors are activated.

Recommended distance sensor to sensing plate 5 - 25 mm.

For Double box installation, same on other side.

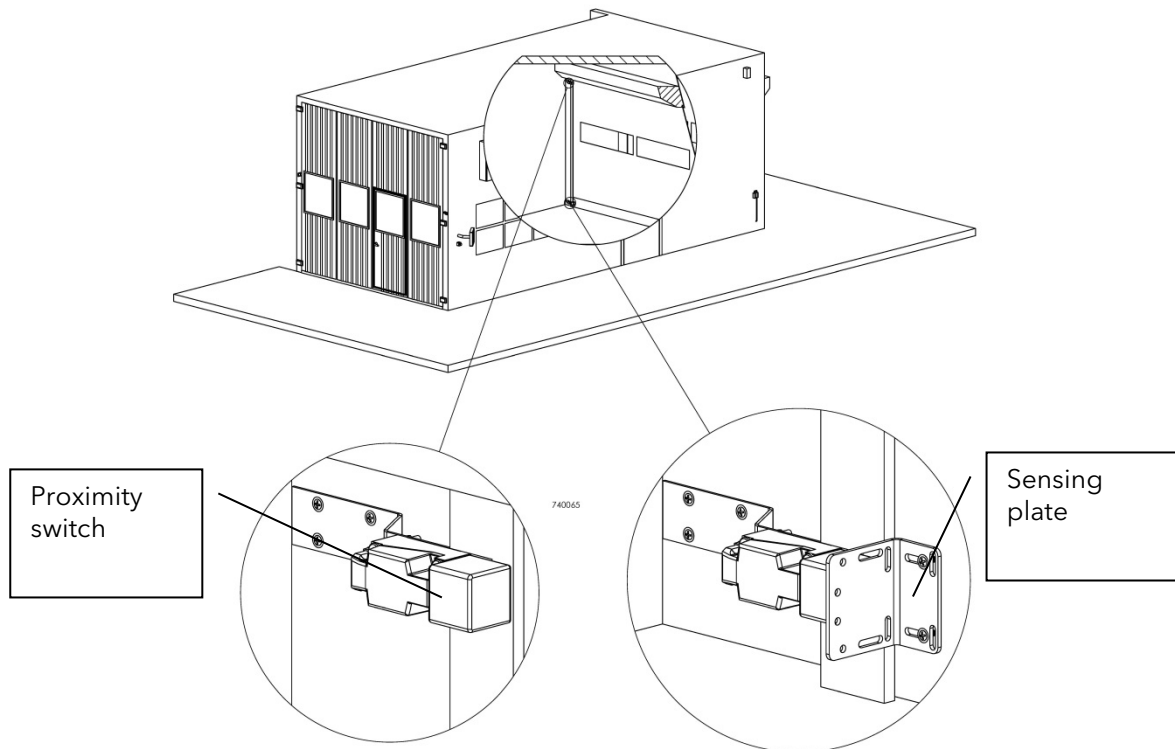

7.10 Emergency stop and entry door switches

The Emergency stop should be placed at the Operator's Panel indicated in the image 1 below.

The entry door switches should be placed at every entry door.

Two different types of switches are included:

1 pcs of photo electric sensor to be mounted on a folding door option. Mounting height should be adapted to cover a potential extra entry door in the folding door (image 1).

1 pce of proximity switch to be mounted on regular entry door (image 1) or roller door (image 2)

See 6.1.

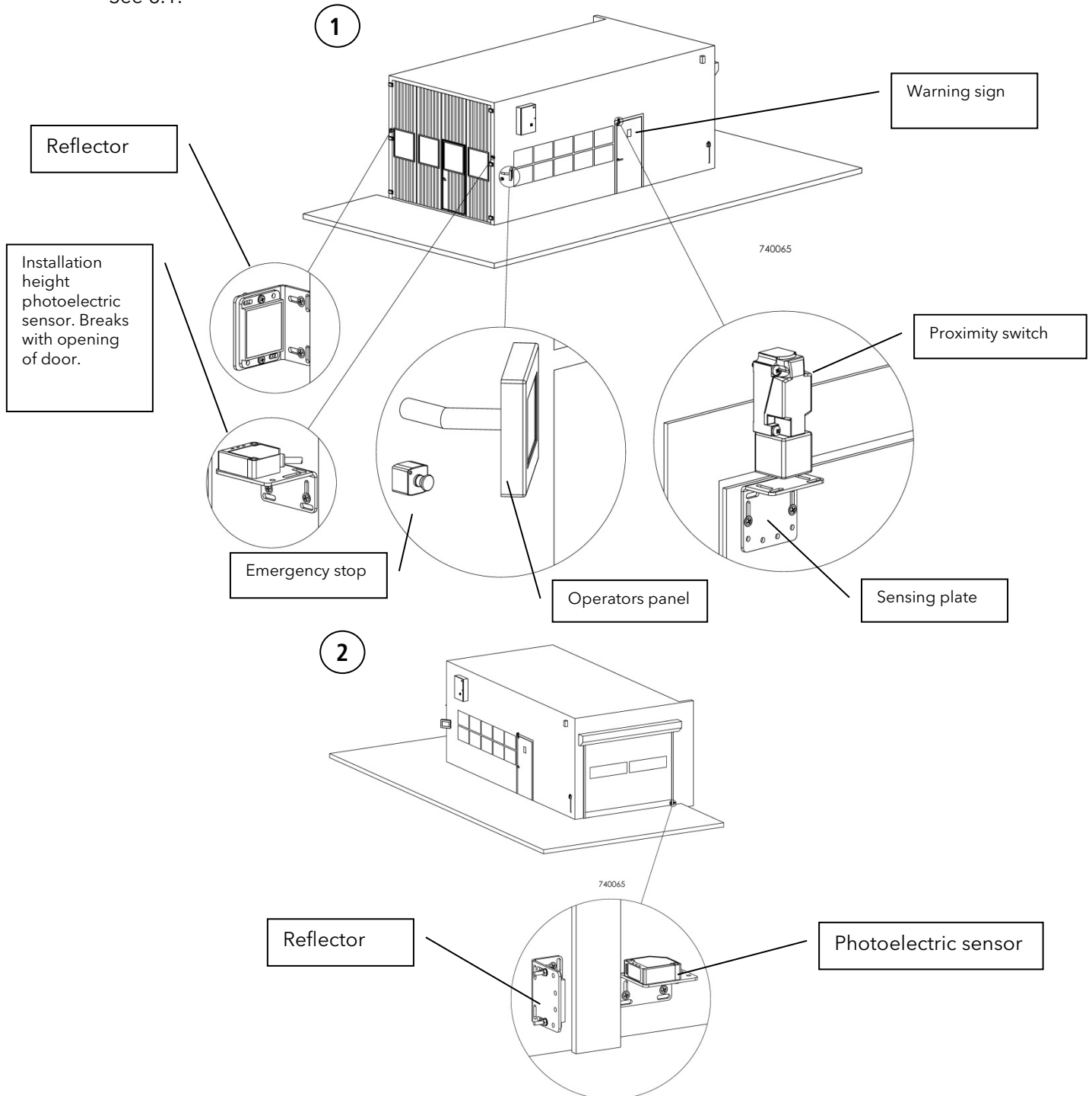

For Double box installation, same on other side.

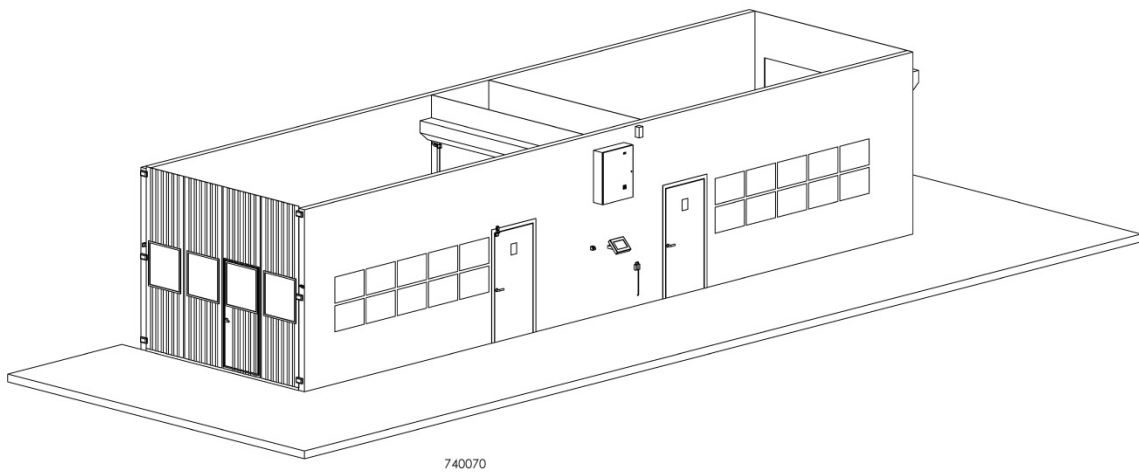
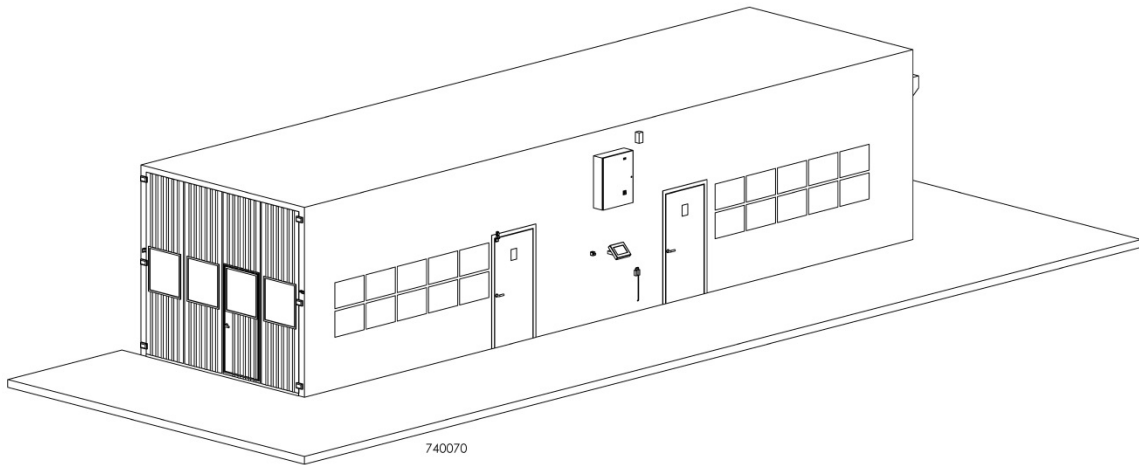

8 Operator panel settings at installation

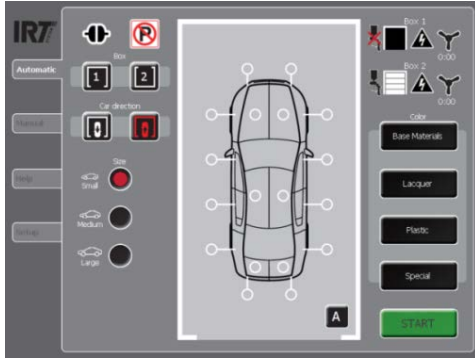

8.1 Accessing the settings area

Power up the unit by switching on the main switch of the surveillance unit and the switch to the right at the bottom of the operator panel. The operator panel will show the start page. Press Setup for access to the settings area.

8.2 Entering the parameter settings

By selecting Drying Recipes or Car Sizes you are requested to enter a code (to receive from IRT). After pressing "Enter", you get access to four pages. Drying Recipes, Car sizes, PLC Settings and Machine Configuration. Choose Machine Configuration.



8.3 Setting of Floor level (height reading)

Measure the distance between the lower edge of the roof section and the floor and enter the value (in centimetres) in the Floor level box.

8.4 Setting of max travel

PowerCure in parkposition. Go to Manual mode and drive PowerCure to the end of the booth, then turn the wings. Note the distance in centimeters and enter this value in Machine configuration "Booth length".

8.5 Setting of ventilation period

This setting is the time the ventilation booth ventilation system needs to exchange the air in the booth five times. This time can be calculated by the booth manufacturer. The timer starts when the operator switches over to curing (or if an optional air flow switch is installed in the spray airline, when the painter stops spraying). This is according to EN 13355 (2005) 5.8.2.1 b) sect.7, Ventilation. Default value is 180 seconds.

8.6 Allow turn in parking booth

If there is space enough for the arch to turn the wings before it has totally left the garage, check the box "Allow turn- in P box".

8.7 Switch arrows

If the operator panel has been mounted at the "wrong" side of the booth, you might want to reverse the direction of the arrows used for manual transportation of the arch. This is done by checking the box "Reverse Man- Arrows"

8.8 Language selection

In the basic settings frame, choose the language you prefer. It is possible to change to another language later.

APPENDIX I

Acceptance testing, by responsible fitter, prior to initial start-up.

Installation: Type:.....

Ref.:.....

Tester: Date:

Mechanical part

<u>Monitoring unit and operator's panel</u>	<u>Yes</u>	<u>No</u>
• Installation outside and close to the spray booth	<input type="checkbox"/>	<input type="checkbox"/>
• Inside of the spray booth viewable from operator's panel	<input type="checkbox"/>	<input type="checkbox"/>
 <u>Rail system</u>		
• Securely attached	<input type="checkbox"/>	<input type="checkbox"/>
• Adequate static (rigid walls)	<input type="checkbox"/>	<input type="checkbox"/>
• Contact rails completely protected with labyrinth seal	<input type="checkbox"/>	<input type="checkbox"/>
• Easy running	<input type="checkbox"/>	<input type="checkbox"/>
 <u>Parking position</u>		
• Position switches correctly adjusted and magnets secured	<input type="checkbox"/>	<input type="checkbox"/>
• Securely attached	<input type="checkbox"/>	<input type="checkbox"/>
• Arch easy to introduce	<input type="checkbox"/>	<input type="checkbox"/>
• Arch protected in parked position	<input type="checkbox"/>	<input type="checkbox"/>
 <u>Differential pressure monitor in exhaust air duct</u>		
• Set to produce correct function	<input type="checkbox"/>	<input type="checkbox"/>
• Hose length max. 2M (6 feet)	<input type="checkbox"/>	<input type="checkbox"/>
• No water pocket formation	<input type="checkbox"/>	<input type="checkbox"/>
 <u>Warning signs</u>		
• Sign: <i>Unauthorized persons do not enter</i> mounted on every entry door	<input type="checkbox"/>	<input type="checkbox"/>
 <u>Safety details</u>		
• Emergency stop mounted close to Operator's Panel.	<input type="checkbox"/>	<input type="checkbox"/>
• Door switches covering all entry doors	<input type="checkbox"/>	<input type="checkbox"/>

Test completed

Signature:.....

Date:.....

APPENDIX II

Acceptance testing, by responsible electrician, prior to initial start-up.

Electrical part

Visual inspection

	<u>Yes</u>	<u>No</u>
• Distribution point correctly protected by fuse A	<input type="checkbox"/>	<input type="checkbox"/>
• Mains cable to monitoring unit 4 x ... mm ²	<input type="checkbox"/>	<input type="checkbox"/>
• Mains terminals covered	<input type="checkbox"/>	<input type="checkbox"/>
• Lead-ins securely tighten	<input type="checkbox"/>	<input type="checkbox"/>
• PE and other terminals securely connected	<input type="checkbox"/>	<input type="checkbox"/>
• Contact rail properly connected (PE!)	<input type="checkbox"/>	<input type="checkbox"/>
• Contact rail IP 4 x (labyrinth seal mounted)	<input type="checkbox"/>	<input type="checkbox"/>
• Arch properly connected (PE!)	<input type="checkbox"/>	<input type="checkbox"/>
• Operator's panel properly connected (PE!)	<input type="checkbox"/>	<input type="checkbox"/>
• Measurements according to EN 60204-1 / VDE 0113-1, Chapter 18 Carrying out by measuring instrument (manufacturer, model, serial no.):		

- Reading:
- Reading:
- Reading:
- Reading:

Functional testing, with power off

Differential pressure monitor in exhaust air duct		
• Contact closed during ventilation	<input type="checkbox"/>	<input type="checkbox"/>
• Contact open during ventilation failure	<input type="checkbox"/>	<input type="checkbox"/>

Functional testing, with power on

• Main switch on	<input type="checkbox"/>	<input type="checkbox"/>
• Air extraction on	<input type="checkbox"/>	<input type="checkbox"/>
• Solenoid valve on (spray air on) with arch in parked position and switched to spraying.	<input type="checkbox"/>	<input type="checkbox"/>
• Solenoid valve off (spray air off) when switched to IR curing.	<input type="checkbox"/>	<input type="checkbox"/>
• The arch does not power up after spraying ² or switching to IR drying until the air in the booth has been exchanged five times or three minutes has elapsed	<input type="checkbox"/>	<input type="checkbox"/>

Position switches in park position

• Contacts open when arch leaves park position.	<input type="checkbox"/>	<input type="checkbox"/>
• Contacts close when the arch is in the park position.	<input type="checkbox"/>	<input type="checkbox"/>
• Function testing of the doors and switches. No obstructions.	<input type="checkbox"/>	<input type="checkbox"/>

Safety functions

	<u>Yes</u>	<u>No</u>
• Emergency stop, cuts of all power the PowerCure	<input type="checkbox"/>	<input type="checkbox"/>
• Entry door switches, cuts of all power the PowerCure	<input type="checkbox"/>	<input type="checkbox"/>

Test completed

² Optional airflow switch in the spray air line

APPENDIX III

0	1	2	3	4	5	6	7	8	9																																																																																							
Cable overview																																																																																																
FI0_002																																																																																																
Cable type	Cable description	Device tag	Conductor	Cross-section	Length	Remark																																																																																										
4G35		=750410+750471_S-W1	4	35		Connection point																																																																																										
		=750410+750471_S-W2	4	35		Power supply IR Arch																																																																																										
ÖLFLEX CLASSIC 110		=750410+750471_S-W3	3	1		Solenoid Valve 1 Spraying Booth 1																																																																																										
		=750410+750471_S-W4	3	1		Solenoid Valve 2 Spraying Booth 1																																																																																										
RJ45/Ethernet		=750410+750471_S-W5	-			OPTION Internet																																																																																										
ÖLFLEX CLASSIC 110		=750410+750471_S-W6	4	1		Roller Door Booth 1 Open																																																																																										
		=750410+750471_S-W7	3	1		Temperature Sensor Spraying Booth																																																																																										
		=750410+750471_S-W8	3	1		Sensor Flow Spraying (Options)																																																																																										
		=750410+750471_S-W9	3	1		External ready signal																																																																																										
		=750410+750471_S-W10	5	1		Roller Door Booth 1 Up																																																																																										
		=750410+750471_S-W11	5	1		Emergency stop																																																																																										
ÖLFLEX CLASSIC 100 (Incl.)		=750410+750471_S-W12	3	0,75	20	Operators Panel																																																																																										
ÖLFLEX CLASSIC 110		=750410+750471_S-W13	3	1		Air Pressure switch Exhaust Air Booth																																																																																										
		=750410+750471_S-W14	3	1		Air Pressure Switch Solenoid valve Spraying																																																																																										
		=750410+750471_S-W15	4	1		Sensor Roller door Booth 1 Closed																																																																																										
		=750410+750471_S-W16	5	1		Sensor Booth Closed Car																																																																																										
		=750410+750471_S-W17	4	1		Sensor Booth Closed																																																																																										
<table border="1" style="width: 100%; border-collapse: collapse;"> <tr> <td style="width: 15%;">ART284</td> <td style="width: 15%;">2017-05-09</td> <td style="width: 15%;">MR</td> <td style="width: 15%;">2017-05-09</td> <td style="width: 15%;">750410_PowerCure</td> <td style="width: 15%;"></td> <td style="width: 15%;"></td> <td style="width: 15%;"></td> <td style="width: 15%;"></td> <td style="width: 15%;"></td> </tr> <tr> <td>ART729</td> <td>2016-04-01</td> <td>MR</td> <td>2016-04-01</td> <td></td> <td></td> <td></td> <td></td> <td></td> <td></td> </tr> <tr> <td>ART729</td> <td>2016-01-19</td> <td>MR</td> <td></td> <td></td> <td></td> <td></td> <td></td> <td></td> <td></td> </tr> <tr> <td>Modification</td> <td>Date</td> <td>Name</td> <td>Source</td> <td colspan="6">Cable overview : =750410+750471_S-W1 - =750410+750471_S-W17</td> </tr> </table>										ART284	2017-05-09	MR	2017-05-09	750410_PowerCure						ART729	2016-04-01	MR	2016-04-01							ART729	2016-01-19	MR								Modification	Date	Name	Source	Cable overview : =750410+750471_S-W1 - =750410+750471_S-W17																																																				
ART284	2017-05-09	MR	2017-05-09	750410_PowerCure																																																																																												
ART729	2016-04-01	MR	2016-04-01																																																																																													
ART729	2016-01-19	MR																																																																																														
Modification	Date	Name	Source	Cable overview : =750410+750471_S-W1 - =750410+750471_S-W17																																																																																												
<table border="1" style="width: 100%; border-collapse: collapse;"> <tr> <td style="width: 15%;"></td> <td style="width: 15%;"></td> <td style="width: 15%;"></td> <td style="width: 15%;"></td> <td style="width: 15%;"></td> <td style="width: 15%;"></td> <td style="width: 15%;"></td> <td style="width: 15%;"></td> <td style="width: 15%;"></td> <td style="width: 15%;"></td> </tr> <tr> <td colspan="4"></td> <td style="text-align: center;">Hedson Technologies AB</td> <td colspan="6"></td> </tr> <tr> <td colspan="4"></td> <td style="text-align: center;">IRT <small>IR Technology</small></td> <td colspan="6"></td> </tr> <tr> <td colspan="4"></td> <td style="text-align: center;"><small>Revision: 20170509</small></td> <td style="text-align: center;">750410</td> <td colspan="4"></td> <td style="text-align: center;">7002</td> </tr> <tr> <td colspan="4"></td> <td colspan="6"></td> <td style="text-align: center;"><small>Page</small></td> </tr> <tr> <td colspan="4"></td> <td colspan="6"></td> <td style="text-align: center;"><small>7002</small></td> </tr> <tr> <td colspan="4"></td> <td colspan="6"></td> <td style="text-align: center;"><small>Rev. no:</small></td> </tr> <tr> <td colspan="4"></td> <td colspan="6"></td> <td style="text-align: center;"><small>7003</small></td> </tr> </table>																								Hedson Technologies AB											IRT <small>IR Technology</small>											<small>Revision: 20170509</small>	750410					7002											<small>Page</small>											<small>7002</small>											<small>Rev. no:</small>											<small>7003</small>
				Hedson Technologies AB																																																																																												
				IRT <small>IR Technology</small>																																																																																												
				<small>Revision: 20170509</small>	750410					7002																																																																																						
										<small>Page</small>																																																																																						
										<small>7002</small>																																																																																						
										<small>Rev. no:</small>																																																																																						
										<small>7003</small>																																																																																						

THE INFORMATION CONTAINED HEREIN IS PROPRIETARY TO HEDSON TECHNOLOGIES AB AND IS NOT TO BE REPRODUCED OR TRANSMITTED IN ANY FORM OR BY ANY MEANS WITHOUT THE EXPRESS WRITTEN PERMISSION OF HEDSON TECHNOLOGIES AB

APPENDIX IV

0	1	2	3	4	5	6	7	8	9	
Cable overview										
F10_002										
Cable type	Cable description	Device tag	Conductor	Cross-section	Length	Remark				
4G35		=750410+750501_D-W1	4	35		Connection point				
		=750410+750501_D-W2	4	35		Booth 1				
4G10		=750410+750501_D-W3	4	10		Position				
4G35		=750410+750501_D-W4	4	35		Booth 2				
ÖLFLEX CLASSIC 110		=750410+750501_D-W5	3	1		Solenoid Valve 1 Spraying Booth 1				
		=750410+750501_D-W6	3	1		Solenoid Valve 2 Spraying Booth 1				
		=750410+750501_D-W7	3	1		Solenoid Valve 1 Spraying Booth 2				
		=750410+750501_D-W8	3	1		Solenoid Valve 2 Spraying Booth 2				
		=750410+750501_D-W9				OPTION internet				
		=750410+750501_D-W10	3	1		Roller door Booth 1 Open				
		=750410+750501_D-W11	3	1		Roller door Booth 2 Open				
		=750410+750501_D-W12	3	1		Temperature Sensor Spray Booth				
		=750410+750501_D-W13	3	1		Sensor Flow Spraying (Options)				
		=750410+750501_D-W14	3	1		=				
R45/Ethernet		=750410+750501_D-W15	3	1		External ready signal				
		=750410+750501_D-W16	3	0,75	20	Operators Panel				
		=750410+750501_D-W17	5	1		Emergency stop				
		=750410+750501_D-W18	3	1		Air Pressure switch Exhaust Air Booth 1				
		=750410+750501_D-W19	3	1		Air Pressure switch Spraying Booth 1				
		=750410+750501_D-W20	4	1		Sensor Roller door Booth 1 Closed				
		=750410+750501_D-W21	5	1		Sensor Booth 1 Closed Car				
		=750410+750501_D-W22	4	1		Sensor Booth 1 Closed				
		=750410+750501_D-W23	3	1		Air Pressure Switch Exhaust Air Booth 2				
		=750410+750501_D-W24	3	1		Air Pressure Switch Spraying Booth 2				
R45/Ethernet		=750410+750501_D-W25	4	1		Sensor Roller door Booth 2 Closed				
		=750410+750501_D-W26	5	1		Sensor Booth 2 Closed Car				
		=750410+750501_D-W27	4	1		Sensor Booth 2 Closed				

THE INFORMATION CONTAINED HEREIN IS PROPRIETARY TO HEDSON TECHNOLOGIES AB AND IS NOT TO BE REPRODUCED, COMMUNICATED TO A THIRD PERSON, OR USED WITHOUT THE EXPRESS WRITTEN PERMISSION OF HEDSON TECHNOLOGIES AB.

AW7824	2017-05-09	MR	2017-05-09	750410_PowerCure	Hedson Technologies AB	Cable overview : =750410+750501_D-W1 - =750410+750501_D-W27	750410	AW7824 Page 20/83
AW7761	2016-05-09	MR	2016-05-09		IRT			
AW7761	2016-04-27	MR	2016-04-27		IRT			
Modification	Date	Name	Source					

APPENDIX V

THE INFORMATION CONTAINED HEREIN IS PROPRIETARY TO HEDSON TECHNOLOGIES AB AND IS NOT TO BE REPRODUCED, COPIED, OR TRANSMITTED IN ANY FORM OR BY ANY MEANS WITHOUT THE EXPRESS WRITTEN PERMISSION OF HEDSON TECHNOLOGIES AB.

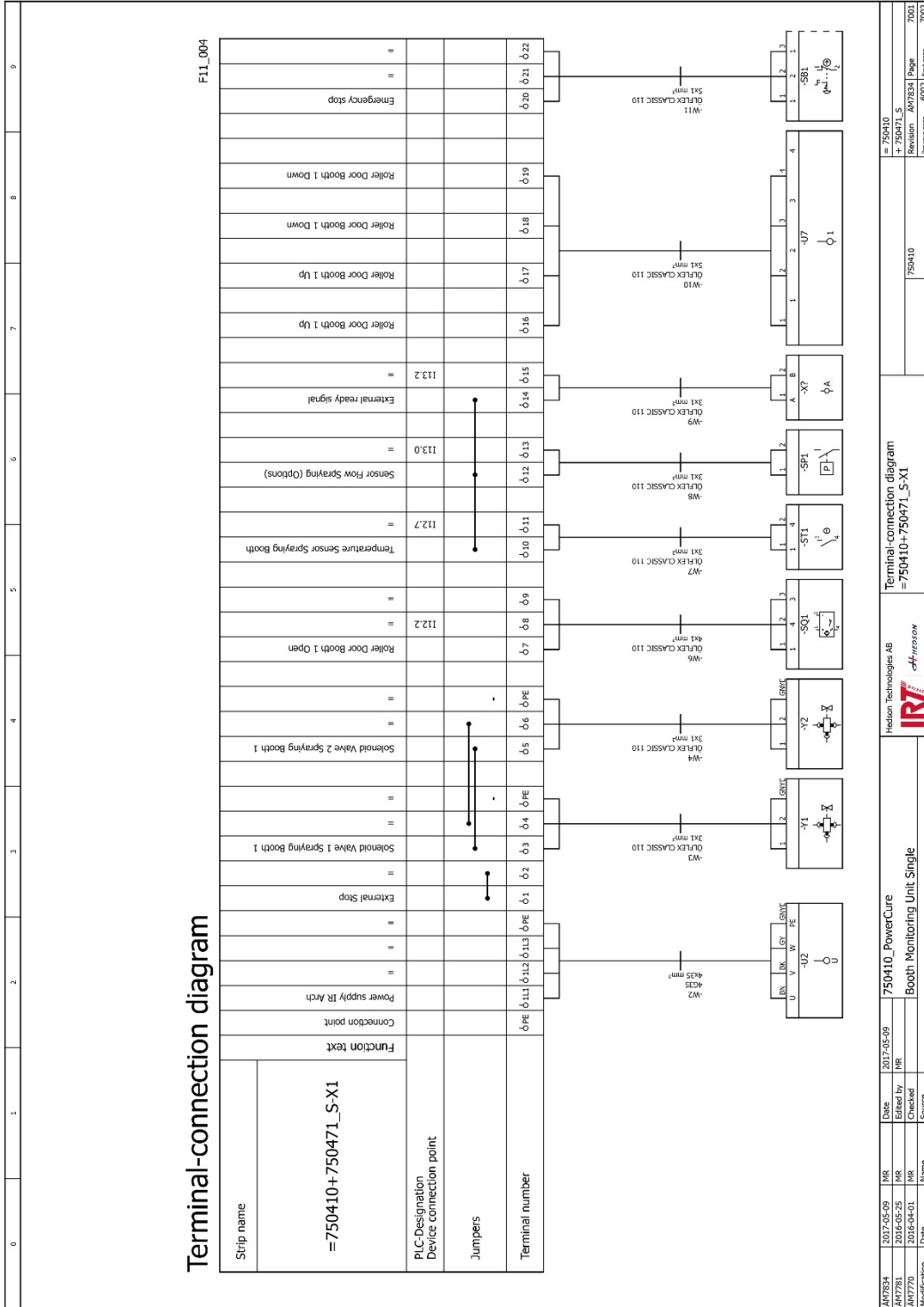

ARI7834	2017-05-09	MR	2017-05-09	750410_PowerCure	Hedson Technologies AB	Terminal-connection diagram	= 750410
ARI7781	2016-05-25	MR					+ 750471_S
ARI7770	2016-04-01	MR					750410
Modification	Date	Name	Source				

APPENDIX VI

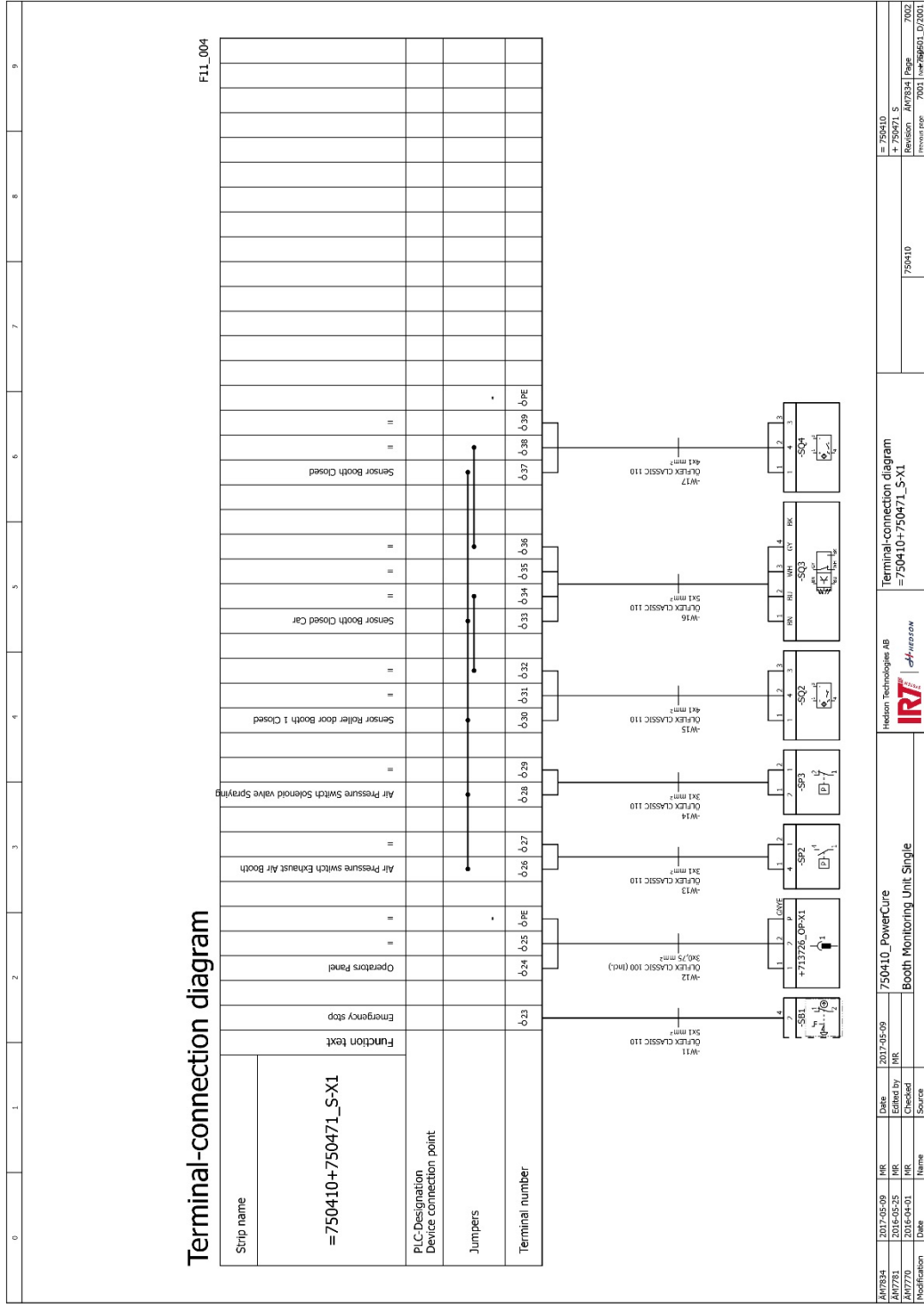

THE INFORMATION CONTAINED HEREIN IS PROPRIETARY TO HEDSON TECHNOLOGIES AB AND IS NOT TO BE REPRODUCED, COMMUNICATED TO A THIRD PERSON, OR USED WITHOUT THE EXPRESSED PERMISSION OF HEDSON TECHNOLOGIES AB

THE INFORMATION CONTAINED HEREIN IS PROPRIETARY TO HEDSON TECHNOLOGIES AB
AND IS NOT TO BE REPRODUCED, COMMUNICATED TO A THIRD PERSON, OR USED
WITHOUT THE EXPRESS WRITTEN PERMISSION OF HEDSON TECHNOLOGIES AB.

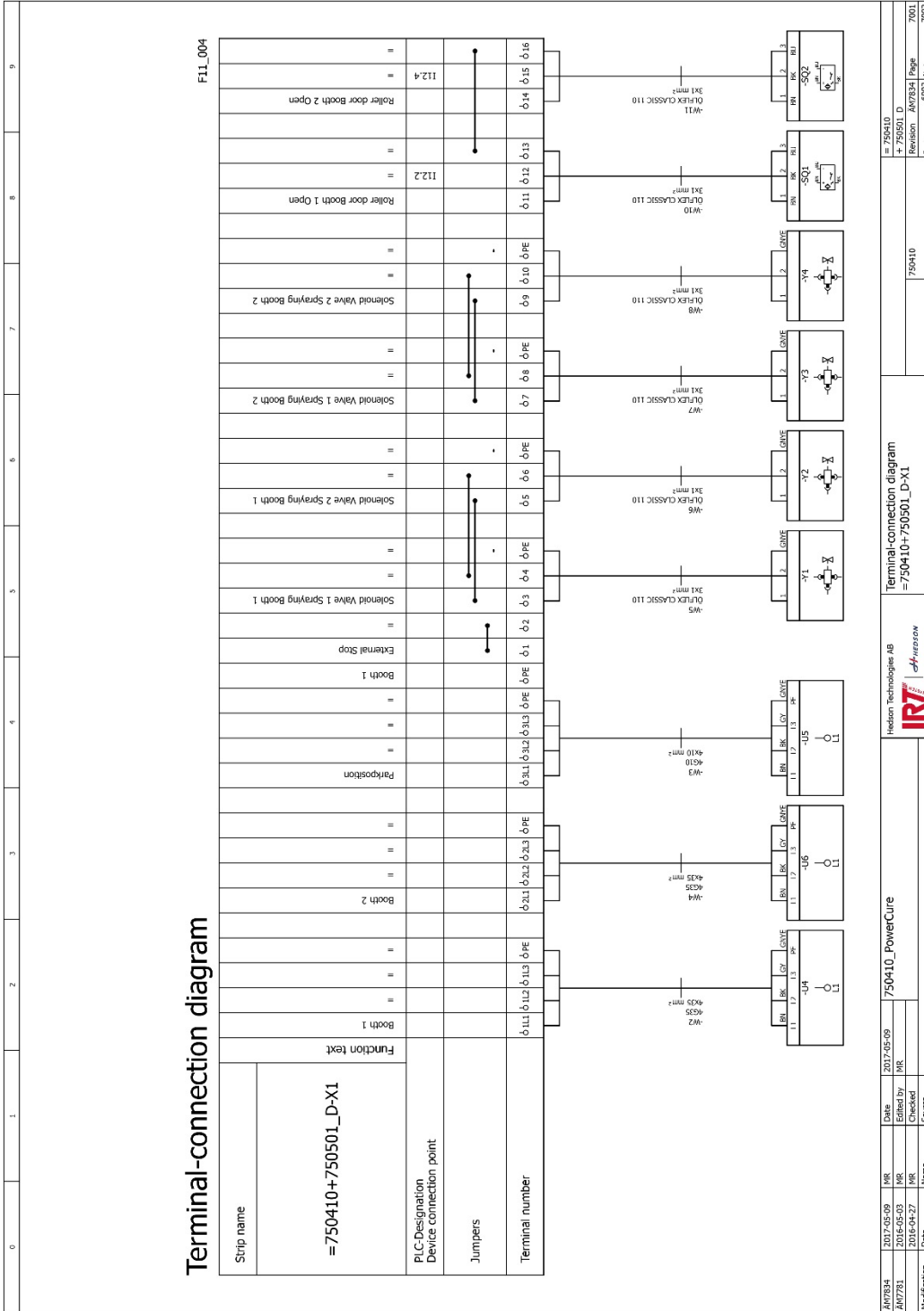

<table border="1" style="width: 100%; border-collapse: collapse;"> <tr> <td>8/17/2014</td> <td>MR</td> <td>2017-05-09</td> <td>750410_PowerCure</td> </tr> <tr> <td>2016-05-03</td> <td>MR</td> <td>Edited by</td> <td>MR</td> </tr> <tr> <td>2016-04-27</td> <td>MR</td> <td>Checked</td> <td>Source</td> </tr> <tr> <td>Modification</td> <td>Date</td> <td>Name</td> <td>Source</td> </tr> </table>	8/17/2014	MR	2017-05-09	750410_PowerCure	2016-05-03	MR	Edited by	MR	2016-04-27	MR	Checked	Source	Modification	Date	Name	Source		Terminal-connection diagram =750410+750501_D-X1	750410 Revision: 6002 Rev: 7002
8/17/2014	MR	2017-05-09	750410_PowerCure																
2016-05-03	MR	Edited by	MR																
2016-04-27	MR	Checked	Source																
Modification	Date	Name	Source																

Terminal-connection diagram

F11_004

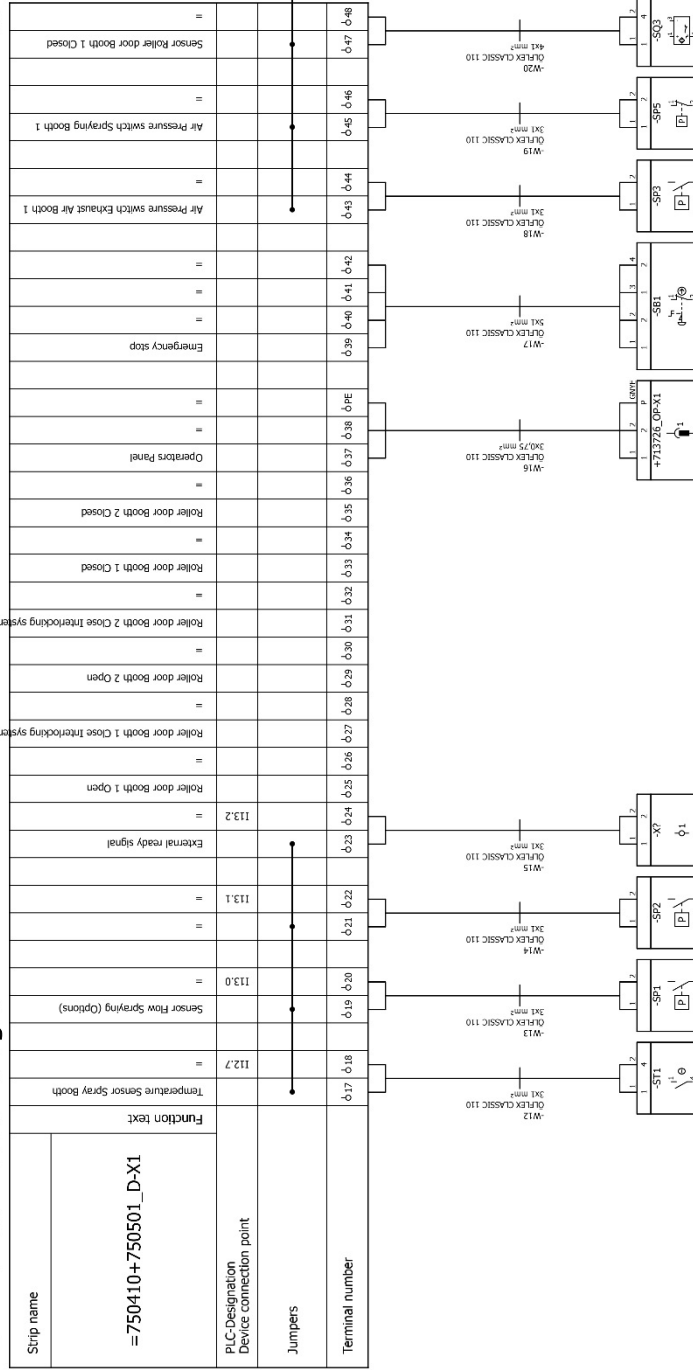

THE INFORMATION CONTAINED HEREIN IS PROPRIETARY TO HEDSON TECHNOLOGIES AB AND IS NOT TO BE REPRODUCED, COPIED, COMMUNICATED TO A THIRD PERSON, OR USED WITHOUT THE EXPRESS WRITTEN PERMISSION OF HEDSON TECHNOLOGIES AB.

0	1	2	3	4	5	6	7	8	9
Strip name									
= 7504110+750501_D-X1									
Function text									
PI-C-Designation Device connection point									
Jumpers									
Terminal number									
17 18 19 20 21 22 23 24 25 26 27 28 29 30 31 32 33 34 35 36 37 38 39 40 41 42 43 44 45 46 47 48									
Temperature Sensor Spray Booth									
Sensor Flow Spraying (Options)									
External ready signal									
Roller door Booth 1 Open									
Roller door Booth 1 Close Interlocking system									
Roller door Booth 2 Open									
Roller door Booth 2 Close Interlocking system									
Roller door Booth 1 Closed									
Roller door Booth 2 Closed									
Operators Panel									
Emergency stop									
Air Pressure switch Exhaust Air Booth 1									
Air Pressure switch Spraying Booth 1									
Sensor Boiler door Booth 1 Closed									

AN7834	2017-05-09	MR	2017-05-09	750410_PowerCure	Hedson Technologies AB	IRT	IRT	750410	= 750410 + 750501_D + 750501_D-X1	750410	750410	750410	750410
AN7781	2016-05-03	MR	MR										
Modification	Date	Name	Date	Source	Source	Source	Source	Source	Source	Source	Source	Source	Source

THE INFORMATION CONTAINED HEREIN IS PROPRIETARY TO HEDSON TECHNOLOGIES AB AND IS NOT TO BE REPRODUCED, COMMUNICATED TO A THIRD PERSON, OR USED WITHOUT THE EXPRESS WRITTEN PERMISSION OF HEDSON TECHNOLOGIES AB.

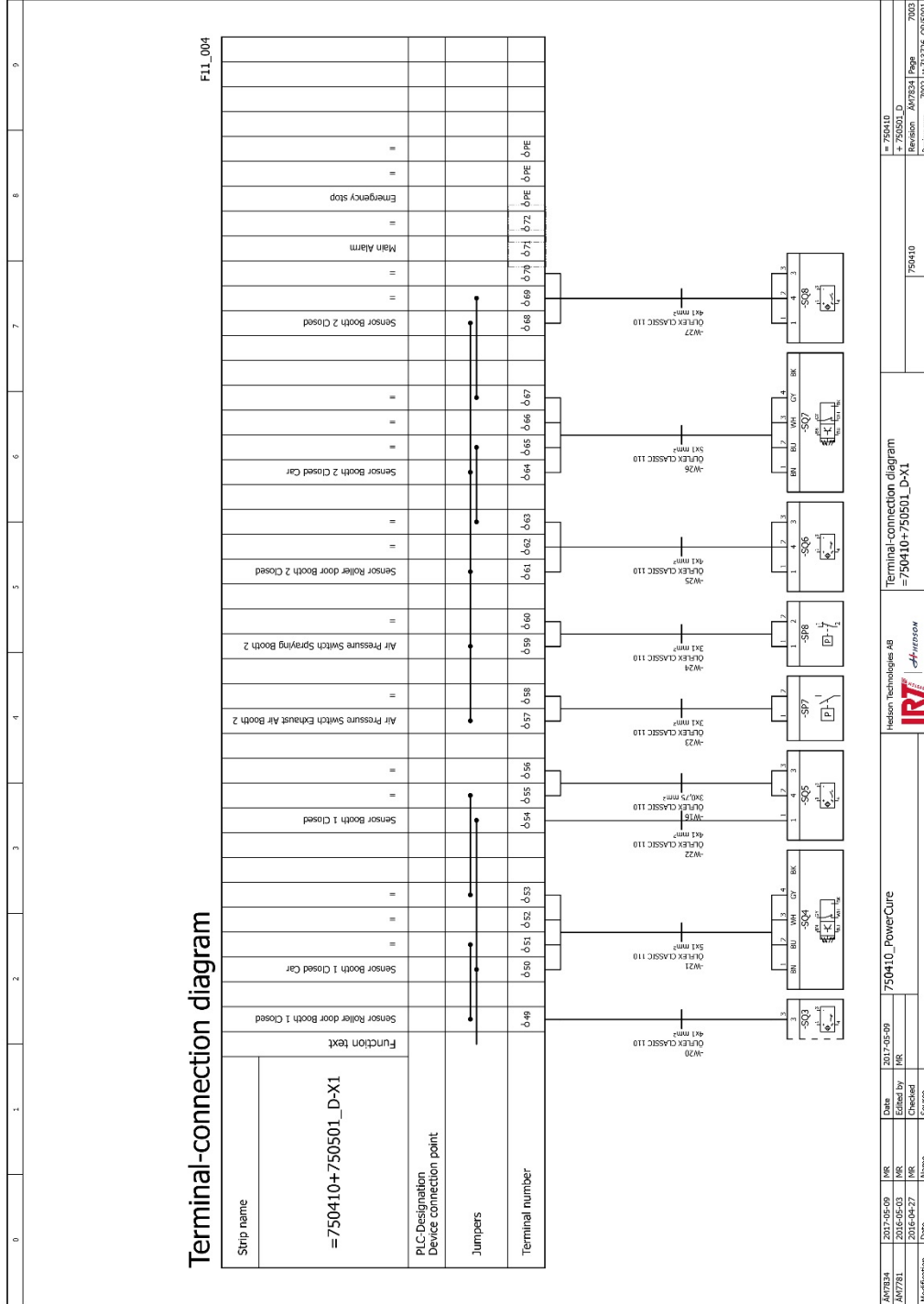

APR284	2017-05-09	Date	2017-05-09	750410_PowerCure
AP7781	2016-05-03	MR	HR	
	2016-04-27	MR	HR	
Modification	Date	Name	Source	

Hedson Technologies AB
IRT *HERKULES* *HEDSON*

Terminal-connection diagram
=750410+750501_D-X1

= 750410 + 750501_D	750410
Revision	APR284
Page	7/103
Part number	75021442436_075010