

Instruction manual (ETL)

IRT COMBI

4-1 IR/UVA
4-10 IR/UVA
4-2 IR/UVA
4-20 IR/UVA



IRT
SYSTEM

The logo for HEDSON, featuring a stylized blue and red 'H' symbol followed by the word 'HEDSON' in a bold, blue, sans-serif font.

TABLE OF CONTENTS

Safety instructions.....	3
1. Intended use of the product	4
2. Product description	4
3. Technical data	4
4. Instructions to the owner	5
5. Markings	6
6. Basic instruction for operation	7
7. Program mode - General rules for navigation in the software....	8
8. Extended usage information.....	9
9. Settings Mode	9
10. Programming examples.....	12
11. Maintenance and service.....	13
12. EC Declaration of conformity	14
13. Electric Diagrams.....	15
14. Spare parts.....	19
15. Weights and dimensions	29

IMPORTANT SAFETY INSTRUCTIONS

When using an electrical equipment, basic precautions should always be followed, including the following:
 READ ALL INSTRUCTIONS BEFORE USING IRT COMBI 4-x IR/UVA



INTENSIVE HEAT RADIATION. HANDS, FACE AND OTHER PARTS OF THE BODY SHOULD BE EXPOSED AS LITTLE AS POSSIBLE TO THE IR RADIATION.
 UV RADIATION CAN CAUSE INJURY AND PROPERTY DAMAGE!

RISK GROUP 3

WARNING. UV emitted from this lamp. Skin or eye injury could result. Avoid exposure of eyes and skin to unshielded lamp.

WARNING. IR emitted from this lamp. Avoid eye exposure without appropriate protection.

(EN62471 and ANSI/IESNA RP-27.3-07)

To reduce risk of injury, or property damage from UV radiation, read, understand, and follow the following safety instructions. In addition, make certain that anyone else that uses this heating equipment follows these safety instructions as well.

- The Equipment emits more than 0.1 $\mu\text{W}/\text{cm}^2$ and shall only be used in locations where access to the equipment and the emissions is restricted to qualified personnel.



- *Wear protective clothing.* Hands, face and other parts of the body shall not be exposed to heat and radiation. Do not stay in front of the lamp cassettes during curing without safety equipment.



- Always wear eye protection. Failure to this may result in longterm injury to the eyes.
- If a person works around UV radiation while on medications, the medication should be checked to see if it would make the person more photosensitive.
- Do not look directly at the light source.
- Do not use if protective glass is broken or missing. This glass filters the light from unwanted radiation.



WARNING

To reduce the risk of fire, electric shock, or injury:

- Do not leave equipment when plugged in. Unplug from outlet when not in use and before servicing.
- Do not allow to be used as a toy. Close attention is necessary when used by or near children.
- Use only as described in this manual. Use only manufacturer's recommended attachments.
- Do not use with damaged cord or plug. If equipment is not working as it should, has been dropped, damaged, left outdoors, or dropped into water, return it to a service center.
- Do not pull or carry by cord, use cord as a handle, close a door on cord, or pull cord around sharp edges or corners. Do not run equipment over cord. Keep cord away from heated surfaces.
- Do not unplug by pulling on cord. To unplug, grasp the plug, not the cord.
- Do not handle plug or equipment with wet hands.
- Turn off all controls before unplugging.
- Do not store, prepare or use solvent-containing materials within a 5 m/16 feet radius of the mobile dryer.
- Flammable materials should not be placed close to a drying device in use.
- Never direct the cassette towards highly combustible materials.
- The dryer must not be exposed to paint fog, sanding dust or solvents, due to fire and explosion risk. Furthermore, the lifetime of the dryer will otherwise be reduced.
- Allow for sufficient cooling time of the dryer.
- The mobile dryer is operated by highly dangerous electrical voltage.
- Before accessing live parts, remove the main connector from the wall socket. Only professional electricians may have direct access into the electrical equipment.
- If the supply cord is damaged, it must be replaced by the manufacturer, its service agent or similarly qualified persons in order to avoid a hazard.



WARNING

Hot surface

The filter glass in front of the UV-lamp can become very hot and has a long cooling down time after operation.

SAVE THESE INSTRUCTIONS

1. Intended use of the product

This product serves exclusively to accelerate the drying/ curing of putty, filler, base and clear coats. This applies to both water-borne and solvent-based products. Its site of use is the preparation area and finishing area. Within the automotive industry and vehicle repair sectors, it is used to cure small areas before polishing. The product must not be used for other purposes than the described drying processes.

This product should only be used with the filter glass intact.

A missing or broken filter glass will result in hazardous UVC and UVB radiation. For a worker working close to the operating lamp (1,5m) the daily limitation should be set to 1h/working day.

Only original spare parts shall be used to maintain this products high safety.

The maximum ambient temperature during operation should not exceed 40°C. The IRT COMBI 4-1 & 4-2 IR/ UVA dryers must not be used in spray booths or within a distance of 5m from spraying activities in order to avoid explosion risk. This prohibition is also valid for the IRT COMBI 4-10 & 4-20 IR/UVA, if not combined with the IRT Dust Cover and Surveillance System:

2. Product description

The dryer is an essential aid for paint repair on small and medium sized areas.

The easily manoeuvrable IRT COMBI IR/UVA is equipped with one or two compact cassettes. Each cassette is equipped with four infrared (IR) lamps with gold plated free-form reflectors, one UV-lamp and a ventilator. The design, combined with a gas spring, makes positioning of the cassette simple. The IR and UV lamps are easily exchangeable and the reflectors are protected against mechanical damage by a mesh.

The dryer has a selection of sophisticated programs. The time for the IR can be set to 0-30 min and 0-15 min for the UV.

2.1 Drying times

At 60 cm distance

Material	minutes
Putty	5- 6
Filler Bright	10- 15
Filler Dark	10- 15
Waterbase	4- 6
Base coat	4- 8
Top coat	10-15
Clear coat	10-15
Plast Filler	10-15
Plast Topcoat	13-17
PlastiClearcoat	13-17
Final boost	2-4
Soft cure	13-17
UV Putty	4-6
UV Filler	3-6
UV Clearcoat	6-8

2.2 Regulated temperature for IR curing

The dryer has a pyrometer which carefully controls temperature of the object. The computer does not only measure the maximum allowed temperature but also the temperature raise. It ensures that the programmed drying/curing temperature is maintained, thereby achieving optimum curing, without risk for "over burning".

3. Technical data

The emitted IR-radiation is short wave with its intensity peak at 1120 nm. The emitted UV-radiation is UVA 315-400 nm.

IR drying surface at 60 cm, IRT COMBI 4-1 & 4-10 IR/UVA

The figures below show the maximum drying area, when the respective dryer is used at 60 cm distance from black sheet metal.

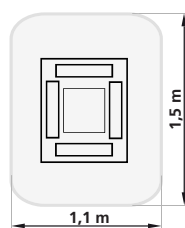

UV drying surface at 50 cm, IRT COMBI 4-1 & 4-10 IR/UVA

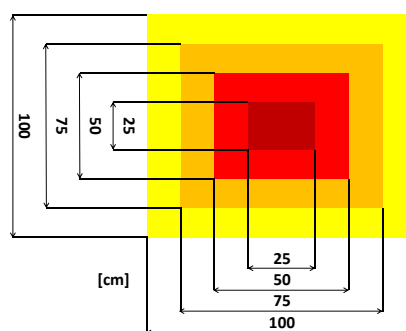
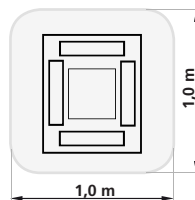

Intensity (W/m²):

	50 cm distance	35 cm distance
Yellow	15-46	15-46
Orange	31-73	62-146
Red	51-82	102-164
Dark Red	65-110	130-200

IRT COMBI 4-1 & 4-10 IR/UVA		
Voltage	230V 1 Ph/PE	230V 3 Ph/PE
Frequency	60 Hz	60 Hz
Current	IR: 26A, UVA: 5A	IR: 15A, UVA: 5A
Power	IR: 6 kW, UVA: 1 kW	IR: 6 kW, UVA: 1 kW
Recommended fuse**		
4-1 IR/UVA	30A*	20A*
4-10 IR/UVA	Max 100A	Max 100A
Drying temp	Max 170°	Max 170°
Noise level	<70 dB(A)	<70 dB(A)

* MCB (Minature Circuit Breaker) type C or D. Normal fuse type slow.

** The dryer shall be operated with a fuse of the recommended rating.

Weight, dimensions and product identity label on last page.

IR drying surface at 60 cm, IRT COMBI 4-2 & 4-20 IR/UVA

The figures below show the maximum drying area, when the respective dryer is used at 60 cm distance from black sheet metal.

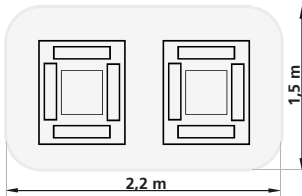

UV drying surface at 50 cm, IRT COMBI 4-2 & 4-20 IR/UVA

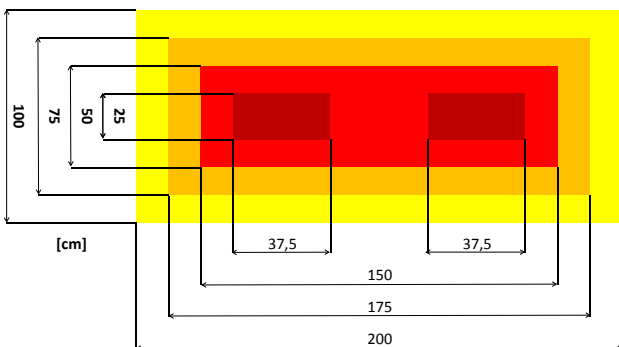
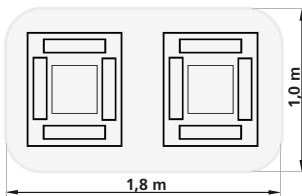

Intensity (W/m²):

	50 cm distance	35 cm distance
Yellow	15-46	15-46
Orange	31-73	62-146
Red	51-82	102-164
Dark Red	65-110	130-200

IRT COMBI 4-2 & 4-20 IR/UVA		
Voltage	230V 1 Ph/PE	230V 3 Ph/PE
Frequency	60 Hz	60 Hz
Current 4-2	IR: 48A, UVA: 10A	IR: 27A, UVA: 10A
Current 4-20	IR: 50A, UVA: 10A	IR: 30A, UVA: 10A
Power	IR: 12 kW, UVA: 2 kW	IR: 12 kW, UVA: 2 kW
Recommended fuse**		
4-2 IR/UVA	50A*	30A*
4-20 IR/UVA	Max 100A	Max 100A
Drying temp	Max 170°	Max 170°
Noise level	<70 dB(A)	<70 dB(A)

* MCB (Minature Circuit Breaker) type C or D. Normal fuse type slow.

** The dryer shall be operated with a fuse of the recommended rating.

Weight, dimensions and product identity label on last page.

4. Instructions to the owner

The owner of the dryer must produce clear operating instructions, adapted to local site conditions, and make these available to all users who have to observe these operating instructions.

This appliance is not intended for use by persons (including children) with reduced physical, sensory or mental capabilities, or lack of experience and knowledge, unless they have been given supervision or instruction concerning use of the appliance by a person responsible for their safety. This product should only be used with the filter glass intact.

A missing or broken filter glass will result in hazardous UVC and UVB radiation. For a worker working close to the operating lamp (1,5m) the daily limitation should be set to 1h/working day.

Only original spare parts shall be used to maintain this products high safety.

Dispose of used items at the nearest environmental protection facility for recycling.

The UV- radiation emission is: according to ANSI/IESNA RP27.3-07 = Risk Group 3 (RG-3)

As appropriate measures; Always wear eye protection during work in areas exposed to UV-radiation.

The lamp used in IRT UV-equipment have a spectrum that start below 250nm but is of an ozone free type. To ensure that the possible concentration of ozone is at a safe value make sure to always work in a well-ventilated environment.

With the temperature control turned off, the temperature might raise quickly and the risk for fire increases, especially if you have a distance less than 60 cm/24" to the object. Never direct the cassette towards highly combustible materials.

For safety reasons the dryer must be supplied by recommended maximum fuse, see tables in chapter 4.1

See separate document for detailed instructions. For mobile dryers: 714838 IRT COMBI 4-1 & 4-2 IR/UVA Mobile Assembly Instruction For rail systems: 713683 IRT Pc Auto 4-10 & 4-20 Rail System Assembly Instruction

5. Markings

Markings on control unit:



714485 **Warning! UV RADIATION CAN CAUSE INJURY AND PROPERTY DAMAGE!**
Always wear eye protection, gloves and protective clothing.

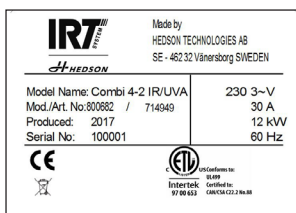
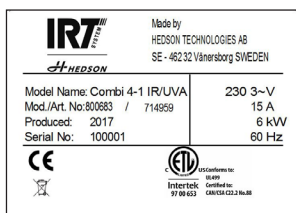

Machine sign

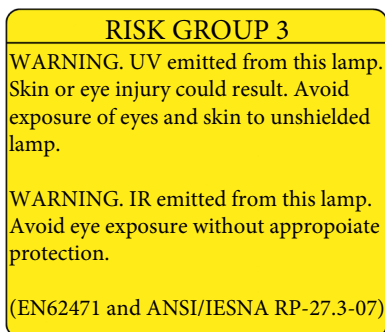

714954 **WARNING. UV emitted from this lamp. Skin or eye injury could result. Avoid exposure of eyes and skin to unshielded lamp. WARNING. IR emitted from this lamp. Avoid eye exposure without appropriate protection.**

(EN62471 and ANSI/IESNA RP-27.3-07)

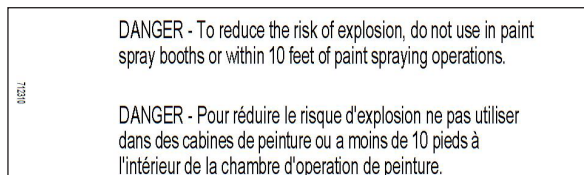

712310 **Danger - To reduce the risk of explosion, do not use in paint spray booths or within 10 feet of paint spraying operations.**

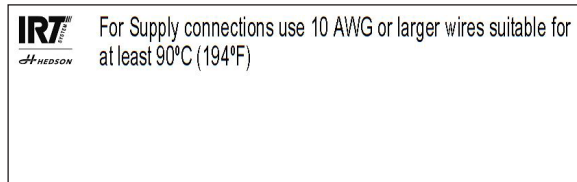
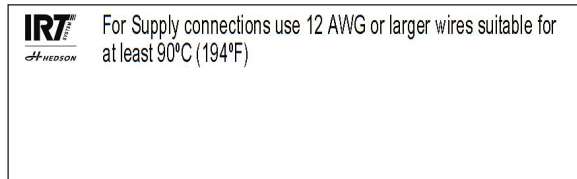
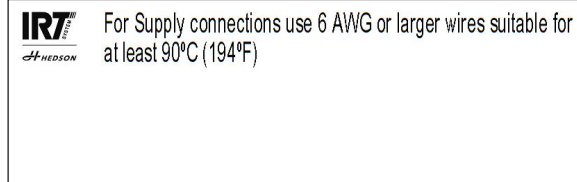
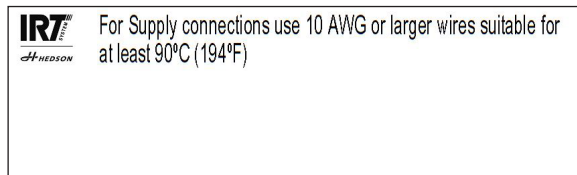

Supply connections information:

IRT Combi 4-1 and 4-10 230V 1PH,
IRT Combi 4-2 and 4-20 230V 1PH
IRT Combi 4-1 and 4-10 230V 3PH,
IRT Combi 4-2 and 4-20 230V 3PH

Markings on cassette:

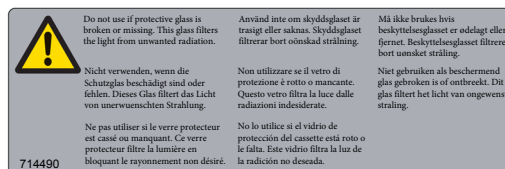

714490 **Do not use if protective glass is broken or missing. This glass filters the light from unwanted radiation.**

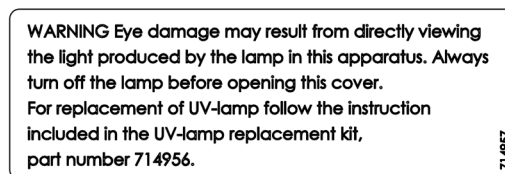

714957 **WARNING Eye damage may result from directly viewing the light produced by the lamp of this apparatus. For replacement of UV-lamp follow the instruction included in the UV-lamp replacement kit, part number 714956.**



410606 (Hot surface)

See separate document for detailed instructions.

For mobile dryers:

714838 IRT COMBI 4-1 & 4-2 IR/UVA Mobile Assembly Instruction

For rail systems:

713683 IRT Pc Auto 4-10 & 4-20 Rail System Assembly Instruction

6. Basic instruction for operation

6.1 Keyboard

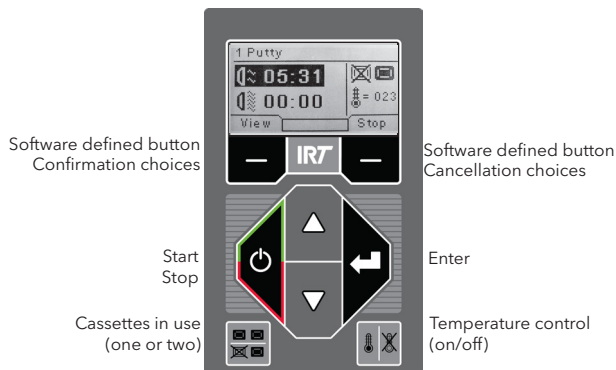

6.2 Display



6.3 Program mode - General rules for navigation in the software

6.3.1 Program mode

This mode is for your everyday use. It helps you run the dryer with preinstalled programs and edit program settings.

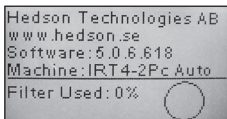

To enter the program mode, turn the main switch on.

When you start the dryer, an information screen will appear for two seconds. By pressing the confirmation or cancellation button this information will show until released. The diagram shows cassette filter usage and notifies when it's time to change filter. To replace filter see chapter "11.1 Filter replacement".

6.4 Settings mode

The Settings mode enables you to change advanced system parameters. Thanks to our advanced control system in this mobile dryer there are many settings that can be altered. This is normally not a part of the everyday usage. To enter the settings mode press both arrow keys when you turn the main switch to position 1. For further information see Chapter 9.

7. Program mode - General rules for navigation in the software

The display shows software defined options in the bottom corner fields. To adjust the values use the arrow keys. To move to previous display without saving, press cancel.

7.1 Basic navigation

There are 12 predefined programs for IR and 3 for UV. All 15 programs have editable names and drying parameters. Scroll up or down using the arrow keys, press select to run the program or view to edit.

1 Putty	6 Topcoat	11 Final boost
2 Filler Bright	7 Clearcoat	12 Soft cure
3 Filler Dark	8 Plastic Filler	13 UV Putty
4 Waterbase	9 Plastic Topcoat	14 UV Filler
5 Basecoat	10 Plastic Clearcoat	15 UV Clearcoat

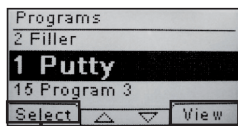

7.2 Run

7.2.1 Distance check

The distance to the object within the circular laser pattern is indicated on the display. Adjust to the desired distance (IR: 60 cm, UVA: 35-50 cm). If measuring fails "check distance manually" appears. Use the buttons on the keyboard to alter between one or two active cassettes and to turn on/off the temp. control. See chapter 8.1.

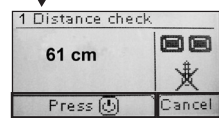

Stop or cancel returns to 7.1.



7.2.2 Start drying

Press start to begin the drying sequence. The remaining time of the "flash off" will start counting down. When the count down is finished, the program automatically changes to full bake mode.

7.2.3 Program graph (only on IR programs)

This graph is available when the temperature control is active. The graph describes the target, actual temperature, and remaining time. See chapter 8.1.

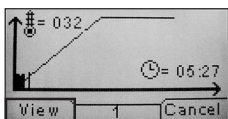

7.2.4 Program values

These are the same values as shown in program graph (7.2.3), except for the remaining time, but also the used power capacity of the machine and the energy consumption of the current drying process.

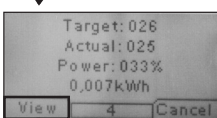

Note! An inactive temperature control does not show temperature values.

7.2.5 Energy consumption

Total energy consumption per drying process is shown for the last 10 runs.

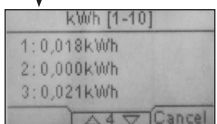

7.2.6 Drying complete

When flash off and full bake times have expired the software returns to 7.1.

Note! To extend the lifetime of the lamps, the ventilators will continue to run for cooling. After 3/6 (IR/UV) minutes they turn off automatically. The UV curing cannot be restarted until after 2 minutes after cooling due to that the hot UV-lamp will not ignite. **Note!** When the drying program is completed the temperature control will automatically reactivate.

7.3 Edit

7.3.1 Properties

The values of the chosen program will show on the display. By pressing the "Temperature control" button the software switches between the properties with and without the temperature control. A change in either property is independent of the other one. See chapter 8.1 for more info.

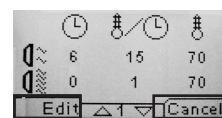

Stop or cancel returns to 7.1.

7.3.2 PIN Code

Use the arrow keys to set the correct digit. Press enter to confirm and to edit the second, third and fourth digit in the advanced PIN code.

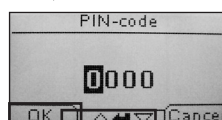

Use arrow keys to set numbers.

Note! An entered PIN code is valid for all entries until the main switch is turned off. See chapter 9.2 for "advanced PIN code".

7.3.3 Edit program parameters

When marked, change the value of the parameters with the arrow keys. Press enter to change the next value and so on. Pressing enter for the last value directs the user to editing of program position and name.



The program returns to 7.3.1.

Press cancel to exit to 7.3.1 without saving any parameters.

7.3.4 Edit prog. name

When marked, change the program name with the arrow keys. Press enter to confirm and to edit the next symbol.

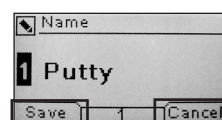

The program returns to 7.3.1.

7.3.5 Expansion of the program steps

When the drying process requires more than the two standard steps, you can expand the number of steps in the drying cycle by linking to the next program.

Start from point 7.3.4 and press "Enter" repeatedly until the "Link to next program" appears on the screen. Select with the arrow keys "Yes" or "No", and then press "Save". The link to the next program will remain until it is deactivated (No).

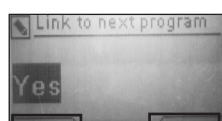

The program returns to 7.3.1.

Note! A UV program cannot be linked to a new UV program due to the necessary cooling time.

8. Extended usage information

8.1 Temperature control (Only valid for IR)

The mobile dryer is equipped with an automatic temperature control. This enables optimum drying/curing results within the shortest possible time.

The properties when the temperature control is on are:

- a. minutes
- b. temperature increase/minute
- c. max allowed temperature

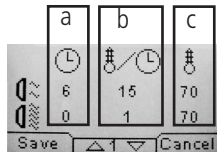

The temperature control (pyrometer) measures the average temperature over a surface. The diameter of this surface equals half of the distance between the IR cassette and the object to be dried. The laser pointer indicates where the distance check is made. This pointer is close to being in the centre of the temperature measurement also.

In settings mode, the short and long limit for a "correct" distance measurement can be adjusted. Default correct distance is between 55 and 65 cm.

Note! The temperature is measured as an average of the measured surface (default diameter value \varnothing 30 cm). Make sure to have the measuring surface placed correctly. Make sure that you don't measure the temperature on glass, tyres or outside the object. Otherwise, the result between the programmed temperature values and actual values may differ. This may lead to unsatisfactory results and if the process alarm is activated it will stop the drying/curing.

Consequently, for surfaces smaller than \varnothing 30 cm which the temperature control cannot read, we recommend deactivating the temperature control. To permanently deactivate the temp. control see chapter 9.4.9.

With the temp control deactivated the program properties are:

- a minutes
- b percent power of max possible

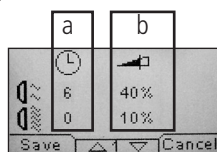

The program settings with or without the temperature control activated are working independently of each other.

8.2 Process alarm (Only valid for IR)

To notice temperature deviations, the mobile dryer is equipped with a process alarm. If the difference between the current temperature and the requested temperature is more than 30 °C, the message "Warning! Process error" appears in the display and the dryer switches off automatically. This warning has to be acknowledged by pressing enter. By doing this, the program is terminated.

In case of process alarm, check if the temperature measuring device (pyrometer) is aligned correctly on the surface to be dried and that it is not registering unwanted material temperatures.

Attention: The process alarm function is not activated when mobile dryer is delivered.

Please see chapter 9.4.3 for activating.

9. Settings Mode

9.1 Log In

To enter the settings mode you first have to "log in". Press both arrow keys as you turn the main switch on. The display will ask you for a PIN code.

9.2 PIN code

Use the arrow keys to fill in the correct digit. Press enter to confirm and edit the second, third, and fourth digit of the code.

No code is required for basic settings, just press OK for the default code of 0000. To change this code, read chapter "9.4.5 Basic PIN code".

Advanced PIN code 5780

Used for program adjustments and advanced settings.

To change this code, read chapter 9.4.13 "Advanced Pin Code".

Attention! An entered PIN code is valid globally in the software until the main switch is turned off, i.e if you enter advanced settings mode and then exit to program mode. The program settings will still be editable until the main power is turned off.

9.3 Navigation

To adjust a setting, press edit. To go back from edit mode to settings mode without saving, press cancel.

Note! If you press exit from settings mode you will be redirected to "program mode". You will then need to repeat from step "9.1 Log In" to enter "9.4 Settings" again.

Navigation example:

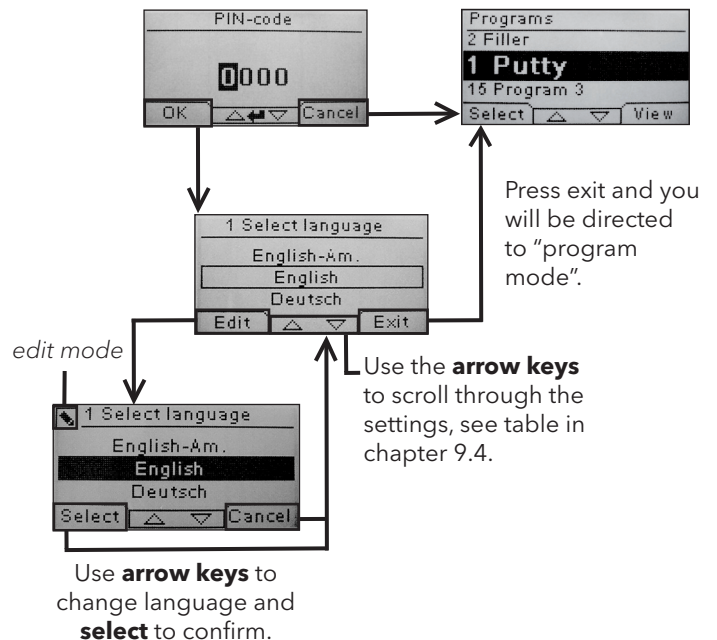

9.4 Settings

Ch.	Overview	available in	
		Basic	Advanced
9.4.1	1 Select Language		x
9.4.2	3 Process Alarm		x
9.4.3	4 Temp Unit		x
9.4.4	5 Buzzer	x	x
9.4.5	7 Basic PIN Code		x
9.4.6	8 Short Dist lim.		x
9.4.7	9 Long Dist lim.		x
9.4.8	15 Temperature Ctrl		x
9.4.9	16 Disp. Contrast	x	x
9.4.10	18 Distance		x
9.4.11	23 Filter Time		x
9.4.12	25 Contin. Mode		x
9.4.13	36 Advanced PIN Code	x	x
9.4.14	37 Dist Unit		x
9.4.15	43 Advanced Code		x
9.4.16	44 Reset Prog. settings		x
9.4.17	45 Reset Filter Timer		x
9.4.18	46 Statistics	x	x
9.4.19	47 Perform Self test	x	x
9.4.20	48 Program Time Scale		x
9.4.21	49 Proc. Alarm Temp		x
9.4.22	53 UV Run time	x	x

9.4.1 1 Select Language

Use the up and down arrow keys to scroll through the fourteen different languages (arranged alphabetically) until the correct language appears. Press select to confirm. If you accidentally switch to a language that you don't understand, turn the main switch on while pressing the "cassette in use" button. The dryer will then start up with British English.

9.4.2 3 Process Alarm

Use the up and down arrow keys to set whether the alarm is active or not. Press select to confirm. For alarm sound settings, see "9.4.4 Buzzer".

9.4.3 4 Temp. Unit

°C and °F appear on the screen. Use the up and down arrow keys to select the desired temperature unit. Confirm the selected unit by pressing select.

9.4.4 5 Buzzer

The sound effects can be muted/activated by using the arrow keys to select no/yes. Press select to confirm.

9.4.5 7 Basic PIN Code

You can change the PIN code to prevent unauthorized access to the basic settings, as described in table in chapter 9.4. To do this use the up and down arrow keys to change the first digit, press select to confirm. Continue with the second, third and fourth digit. When completed press select to confirm the new four digit PIN code.

9.4.6 8 Short Distance Limit

The original settings for the correct short distance limit is 55 cm. You can change the value for the short distance limit from 35 to 95 cm. Settings higher than 80 cm are not recommended. Press select to confirm.

9.4.7 9 Long Distance Limit

The original settings for the correct long distance limit is 65 cm. You can change the value for the long distance limit from 40 to 130 cm. Settings higher than 100 cm are not recommended. Press select to confirm.

9.4.8 15 Temperature Ctrl

You can choose if you want to turn the temperature control (pyrometer) on or off permanently.

Note! If you turn the temperature control off in settings mode you cannot activate it in program mode.

Temperature graphs and values will not be accessible when this feature is turned off. Instead the software will work with power levels, that is percentage of maximum capacity.

9.4.9 16 Disp. Contrast

You can change the contrast of the display on a scale from light to dark (25-55). Scroll between the values with the up and down arrow keys and press select to confirm.

9.4.10 18 Distance

You can change the distance measuring between centimeters and text. If text is chosen the distance is indicated on the display as "too close", "too far" or "correct". If measuring fails "check distance manually" appears.

9.4.11 23 Filter Time

The default value is 400 working hours. After this time, the filter replacement warning is displayed for filter change. If the mobile dryer is placed in a dusty environment, it is recommended to change more frequently.

Note! Keep in mind that if the filter is too dirty, the lamp service life will be reduced as a result of impaired cooling. To reset, see "9.4.17 Reset filter timer".

9.4.12 25 Contin. Mode

The continuous mode is for sales demo purposes. For safety reasons and for minimizing unnecessary wearing down of the dryer, this mode must only be used in exceptional cases.

9.4.13 36 Advanced Pin Code

To change the code to your personal choice use the up and down arrow keys to change the first digit, press select to confirm. Continue with the second, third and fourth digit. When completed press select to confirm the new four digit PIN code.

Warning! Make sure that you remember the new code.

9.4.14 37 Dist Unit

This provides you with the opportunity to change unit type between centimeters and inches.

9.4.15 43 Advanced Code

It is possible to enable/disable the request for a PIN code. This will remove the PIN code request in program mode and the code 0000 will give you access to advanced settings.

Press select to confirm your choice.

9.4.16 44 Reset Prog. settings

You can reset to the pre-programmed factory settings for all programs. Confirm by pressing yes.

9.4.17 45 Reset Filter Timer

After a filter change on the cassette/s, restart the filter timer with this setting. Confirm by pressing yes to reset the filter time counting.

To adjust the value in the filter timer, see chapter 9.4.11.

9.4.18 46 Statistics

The following information is available:

Run time

Shows accumulated working hours and minutes.

Start-ups

Shows the total number of starts of the dryer.

Σ (Total Power Consumption)

Presents the total energy consumption.

Φ (Average power consumption)

Presents the average consumption for all runs

9.4.19 47 Perform Self test

The best fault trace software on the market has been developed with this dryer. In this test all the important input and outputs to and from the computer can be tested. This test will give the opportunity for a quick and accurate function verification of the different parts of the dryer. This test procedure is only available in English. By pressing the yes button you enter the first step of the self test. To exit the self test, press the start/stop button.

Automatic testing includes the following:

Test 1: Push Button Test

All buttons on the control unit are tested. The corresponding symbols are displayed by pressing the buttons. Press enter for approx. three seconds in order to continue to the next step of the test program.

Test 2: Display Test

Verify that all pixels light up on the display. Press enter* and check that all pixels go out. Press enter* to continue.

*) or upper left software button

Test 3: Buzzer Test

Check that the buzzer sounds. Press enter or next to continue.

Test 4: Cassette IR Test

The IR cassette lamps light up. Check that all the IR lamps are lit.

For safety reasons this test is limited to 10 seconds. Press enter or next to continue.

Test 5: Ventilator Test/cassette

The ventilator in the cassette now starts. A sound from the ventilator confirms that it is working. Press enter or next to continue.

Test 6: Cassette UV Test

The UV lamp lights up. Check that the UV lamp is lit. For safety reasons this test is limited to 10 seconds. Press enter or next to continue.

If the dryer is equipped with two cassettes, you will have to repeat test no. 4-6 for cassette 2.

Test 7: Laser Test

Direct the laser towards the object. Check that a red, dotted circle is visible on the object. Press enter or next to continue.

Test 8: Temperature Sensor Test

Direct the temperature sensor towards an object that is at room temperature. The temperature on the display should not deviate from room temperature by more than ± 3 °C or ± 5 °F. Press enter or next to continue.

Note!

Temperature measurement is made as an average of a surface according to chapter 8.1.

Test 9: Distance Sensor Test

Direct the distance sensor towards the object at a distance of 0,3 -1 m. Check that the distance shown on the display matches the manually measured distance. A deviation of ± 3 cm is acceptable.

Press enter or next to continue.

Test 10: Temperature Guards

The computer card has a temperature measuring device that is seen on the display. The temperature is shown in °C or °F depending on the settings you have made. The computer lifetime will be shortened if temperatures are above 70 °C/158 °F during operation. If this happens during drying a new window will appear after the completed drying cycle saying "warning High temp Pc".

Glass break detector: value must be >2500.

Test Completed

Automatic testing is now complete. Press enter or next to finish.

9.4.20 48 Program Time Scale

Possibility to change between minutes and seconds.

9.4.21 49 Proc. Alarm Temp.

Possibility to set maximum temperature difference between current and requested temperature (5-99 °C). This function is activated in 9.4.2.

9.4.22 53 UV Run time

Total run time for each UV-lamp.

10. Programming examples

EX 1.

FLASH OFF/PREHEATING

Initial temperature 20 °C/86 °F
 Time 4 min
 Temperature increase 15 °C/27 °F/min
 Final temperature 80 °C/176 °F

FULL BAKE/CURING

Initial temperature 60 °C/140 °F
 Time 0 min
 Temperature increase 5 °C/9 °F/min

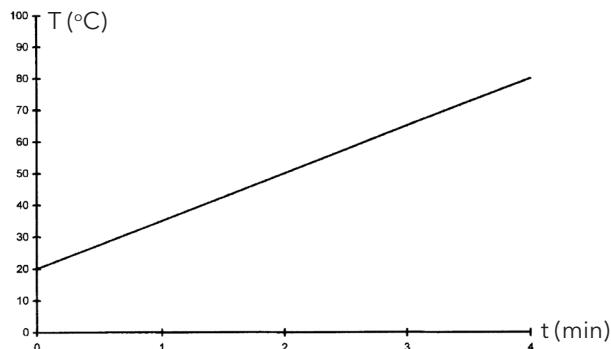

EX 2.

FLASH OFF/PREHEATING

Initial temperature 20 °C/86 °F
 Time 4 min
 Temperature increase 20 °C/36 °F/min
 Final temperature 60 °C/140 °F

FULL BAKE/CURING

Initial temperature 60 °C/140 °F
 Time 5 min
 Temperature increase 5 °C/9 °F/min
 Final temperature 60 °C/140 °F

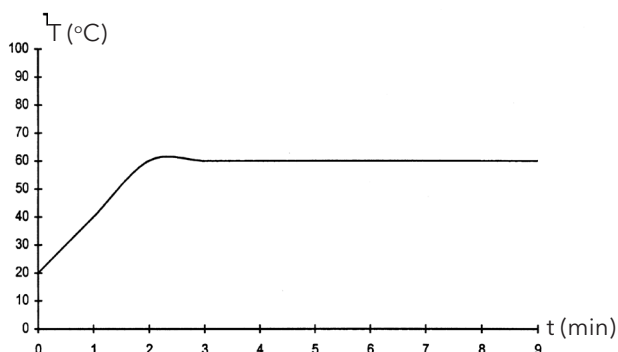

EX 3.

FLASH OFF/PREHEATING

Initial temperature 20 °C/86 °F
 Time 4 min
 Temperature increase 10 °C/18 °F/min
 Final temperature 60 °C/140 °F

FULL BAKE/CURING

Initial temperature 60 °C/140 °F
 Time 8 min
 Temperature increase 20 °C/36 °F/min
 Final temperature 110 °C/230 °F/min

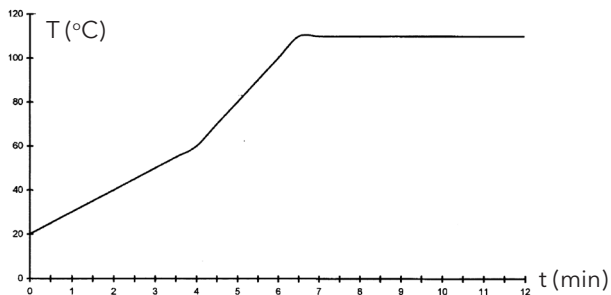

EX 4.

FLASH OFF/PREHEATING

Initial temperature 20 °C/86 °F
 Time 6 min
 Temperature increase 20 °C/36 °F/min
 Final temperature 60 °C/140 °F

FULL BAKE/CURING

Initial temperature 60 °C/140 °F
 Time 6 min
 Temperature increase 15 °C/27 °F/min
 Final temperature 90 °C/194 °F

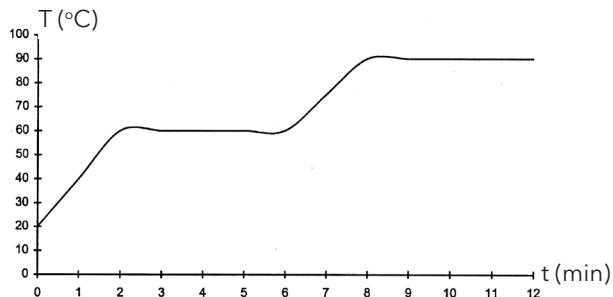

11. Maintenance and service

Before every usage, check that:

- external cabling is not damaged
- protection glass in front of lamp is not cracked or removed
- protection glass is clean and free from spray fog that decreases the intensity

Weekly

Check that all IR and UV lamps light up during mobile dryer operation. Defect IR lamps can cause uneven heat distribution over the surface.

Clean the dryer from dust, which can be a cause of fire, with a damp cloth. Also, check that all cables are undamaged. A damaged cable can be a danger to life!

Monthly

Check the gold reflectors. Damaged or extremely dirty reflectors can over heat the reflector body and/or the cassette. In case of doubt, please contact the customer service in order to clarify if the gold coated reflector needs to be changed.

Quarterly

Plan to change the air filter approx. once per year. You will get a message in the software when it is time to change. When starting up the dryer you will get an indication on how much of the filter time that is used.

11.1 Filter replacement

Attention! The filters are disposable and should not be reused.

1. Use a knife or screw driver to bend loose the two plastic plugs at the cassette side plates.
2. Remove the used filter.
3. Insert the new filter so the IRT logo is visible from the outside.
4. Place the long side of the filter opposite to the two plug holes on the cassette according to picture.
5. Push in the filter until the two plastic "push-in-plugs" can be reattached.
6. Reset the filter timer. Log into advanced settings mode according to chapter 9.1 and 9.2. Move to parameter 45 and press yes for reset the filter timer.

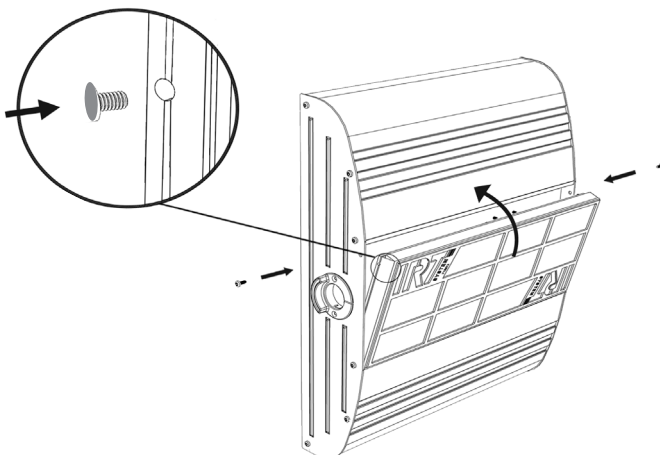

11.2 IR lamp replacement

Attention! Do not touch the gold coated reflector or the new IR lamp with your fingers. Only remove the protective paper on the IR lamp after you have installed it.

1. Disconnect power supply.
2. Loosen the three top screws on the front plate of the cassette.

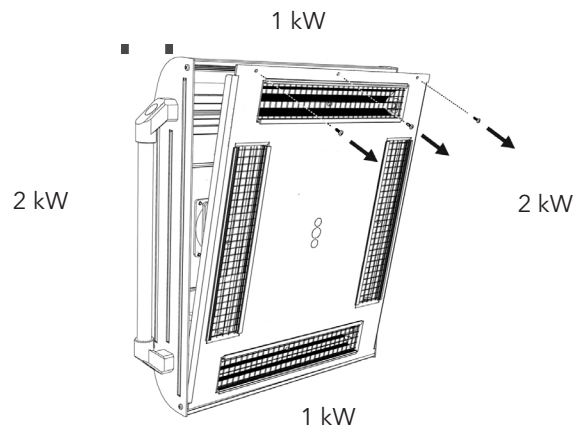

3. Disconnect the cable connector.
4. Loosen the four screws at the ends of the reflector and remove the reflector from the plate.

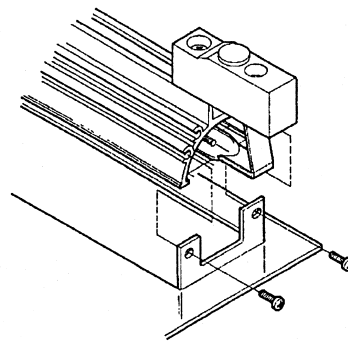

5. Remove the mesh and unscrew the lamp from the two ends.

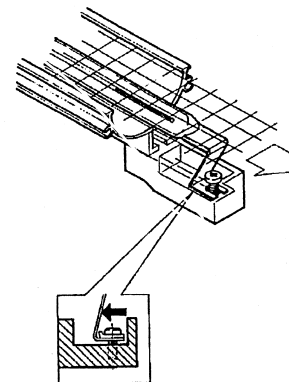

6. Install new lamps in the reverse order.

11.3 UV-lamp replacement

Please contact your distributor and order a UV-lamp replacement kit including instructions.

11.4 Gas pressure spring replacement

If the mobile arm does not park in highest or lowest position but falls or raises slightly by itself, tighten the 4 bolts indicated with the letter "C" in figure 2. If the arm still does not park or becomes heavy to adjust, the gas pressure spring must be replaced.

Attention! Due to high weight and complexity it is recommended to be two persons or one person with a lifting device when performing this service.

1. Remove the four screws fastening the cover that is located on either side of the arm. (figure 1)
2. Place the parallel arm in the far most upright position. (figure 2).
3. Before removing the pins holding the gas spring, as much pressure as possible from the gas spring should be relieved. To do this, raise the arm slightly until the pins are loose.
4. Attention! At all times when the gas spring is not securely in position with pins and locking rings, the arm can fall down heavily from it's upright position and create great danger.
5. Remove the locking rings and the two pins. Move the gas spring slightly upwards/forward and then remove it (figure 2).
6. Place the new gas spring in the same direction as the old one. Reassemble in the reversed order.



ATTENTION!

Ensure that the locking rings are refastened properly.

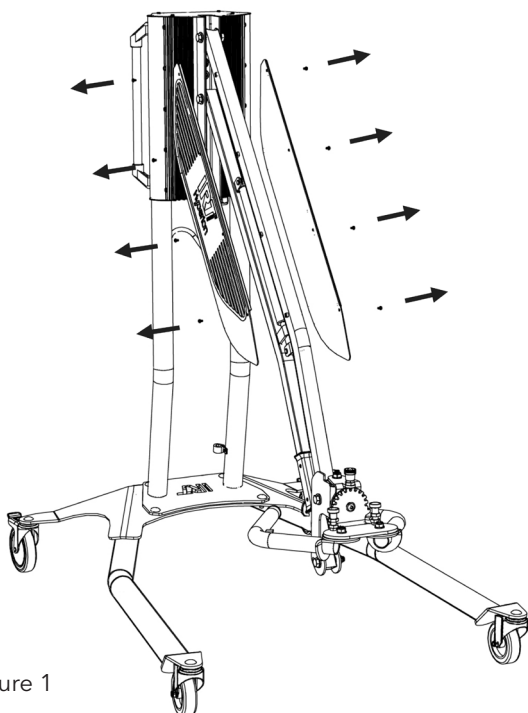

Figure 1

12. EC Declaration of conformity

We, Hedson Technologies AB
Box 1530

SE-462 28 VÄNERSBORG Sweden

declare under our sole responsibility that the products

IRT Combi 4-1 IR/UVA

IRT Combi 4-10 IR/UVA

IRT Combi 4-2 IR/UVA

IRT Combi 4-20 IR/UVA

to which this declaration relates is in conformity to the applicable provisions of US Federal requirements, including the Code of Federal Regulations, CFR Title 21, --FOOD AND DRUGS CHAPTER I--FOOD AND DRUG ADMINISTRATION DEPARTMENT OF HEALTH AND HUMAN SERVICES SUBCHAPTER J--RADIOLOGICAL HEALTH.

IR and UV-curing devices is not included in table 1 of 21 CFR 1002.1 and therefore not subject to a mandatory radiation safety performance standard contained in title 21 CFR Part 1040 (optical radiation) but complies with the general requirements in Title 21 CFR 1000 through 1005.

Following the standards:

UL499 14th Ed. issued Nov. 7, 2014.

CSA C22.2 No.88 issued: 1958/09/01

Arlöv, Sweden, October 2017

HEDSON TECHNOLOGIES AB
Technology Division
Magnus Björnström
CEO

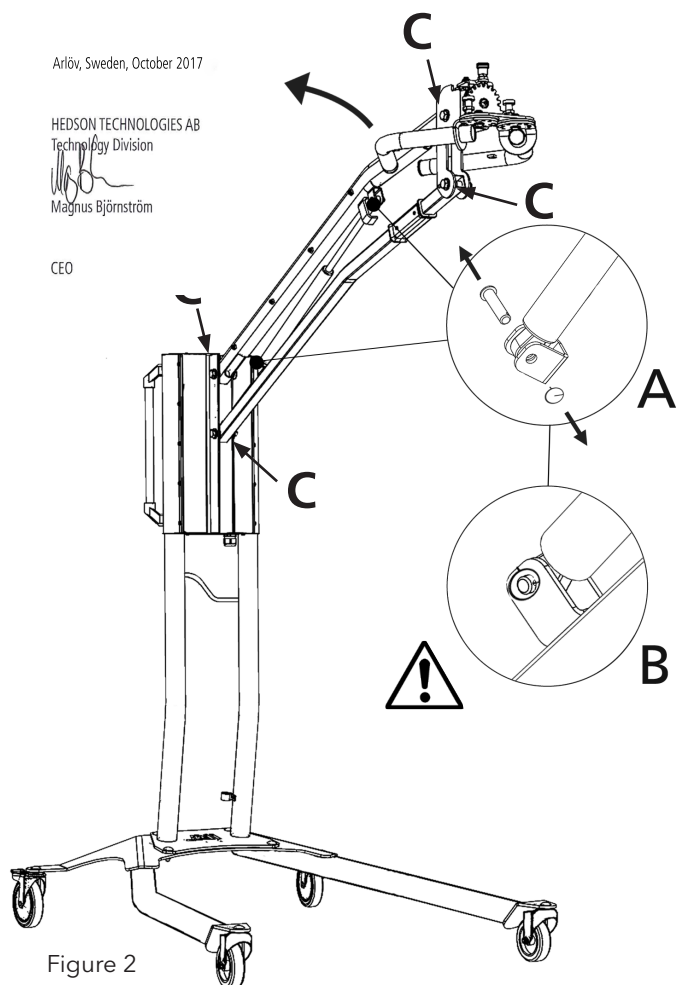
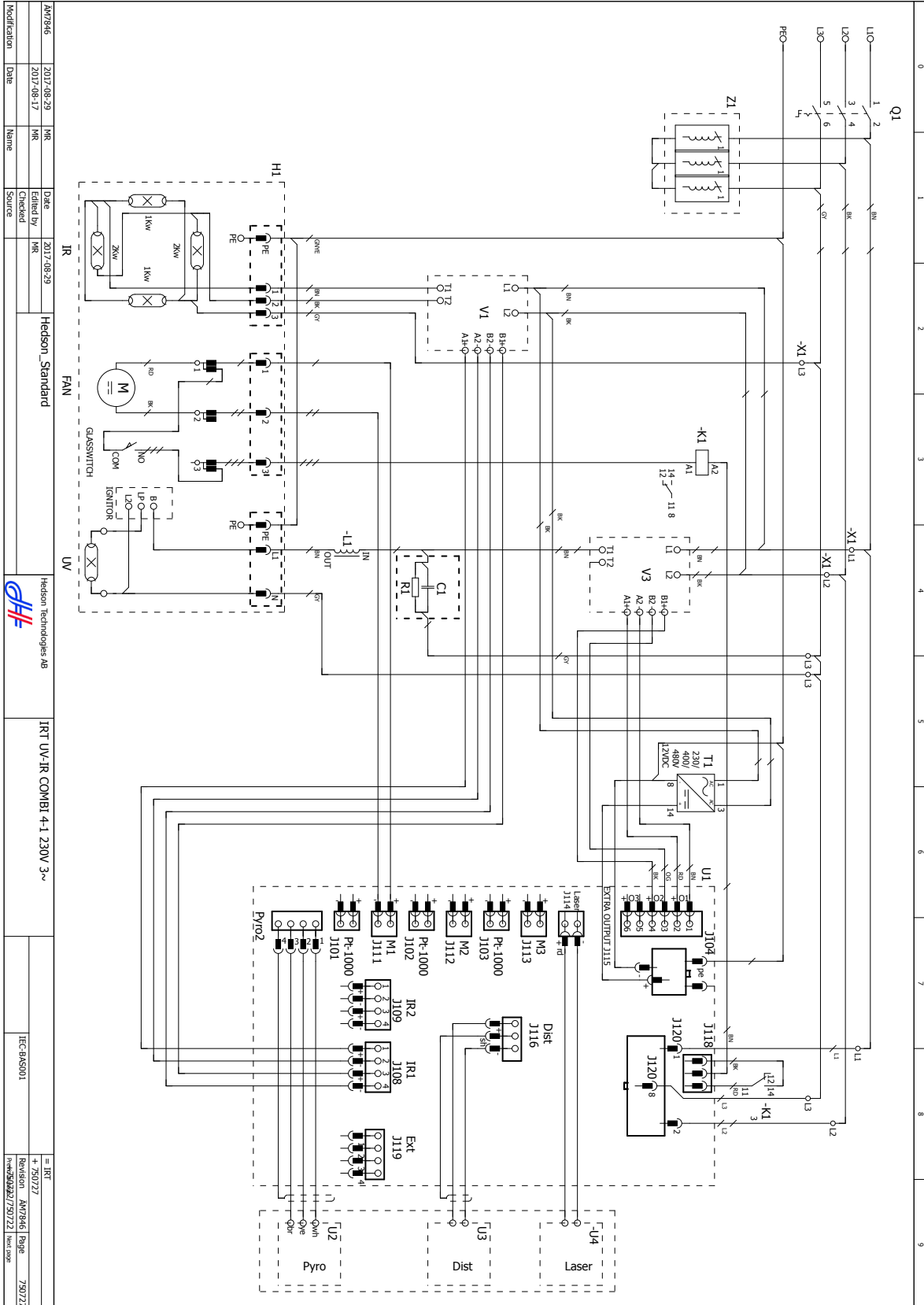

Figure 2

IRT COMBI 4-1 230V 3~



THE INFORMATION CONTAINED HEREIN IS PROPRIETARY TO HEDSON TECHNOLOGIES AB AND IS NOT TO BE REPRODUCED, COMMUNICATED TO A THIRD PERSON, OR USED WITHOUT THE EXPRESS WRITTEN PERMISSION OF HEDSON TECHNOLOGIES AB.

IRT COMBI 4-2 230V 1~

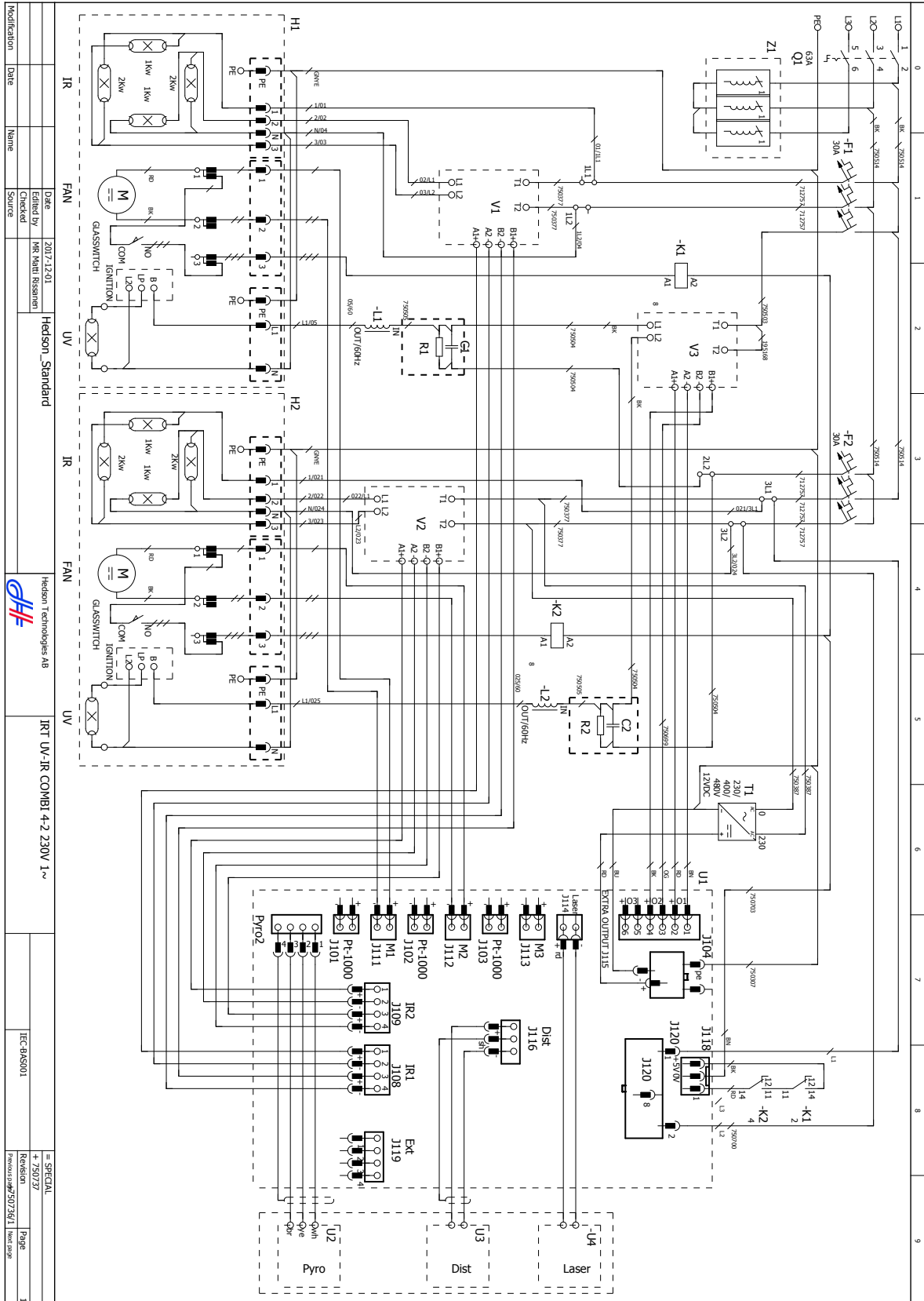

Modification	Date	Name	Date	Checked	Source
			2017-12-01	M.R. Kahl	Rissman
Hedson Standard					
Hedson Technologies AB					
IRT UV-IR COMBI 4-2 230V 1~					
IEC-BAS001					
SPECIAL					
+ 750737					
Revision					
Hedson 10/2017/38/1					
Page					
1					

THE INFORMATION CONTAINED HEREIN IS PROPRIETARY TO HEDSON TECHNOLOGIES AB AND IS NOT TO BE REPRODUCED, COMMUNICATED TO A THIRD PERSON, OR USED WITHOUT THE EXPRESS WRITTEN PERMISSION OF HEDSON TECHNOLOGIES AB.

14. Spare parts

This document is the property of Hedson Technologies and may not be copied without our written permission. The contents thereof must not be imparted to a third party nor be used for any unauthorized purpose. Contravention will be prosecuted.

Den här ritning är Hedson Technologies egendom. Den får inte vara sig i ursprungligt eller ändrat skick utan vårt medgivande kopieras eller mångfaldigas, förvisas för eller på annat sätt delgivas eller utlämnas till tredje person. Överträdelse här av beivras med stöd av gällande lag

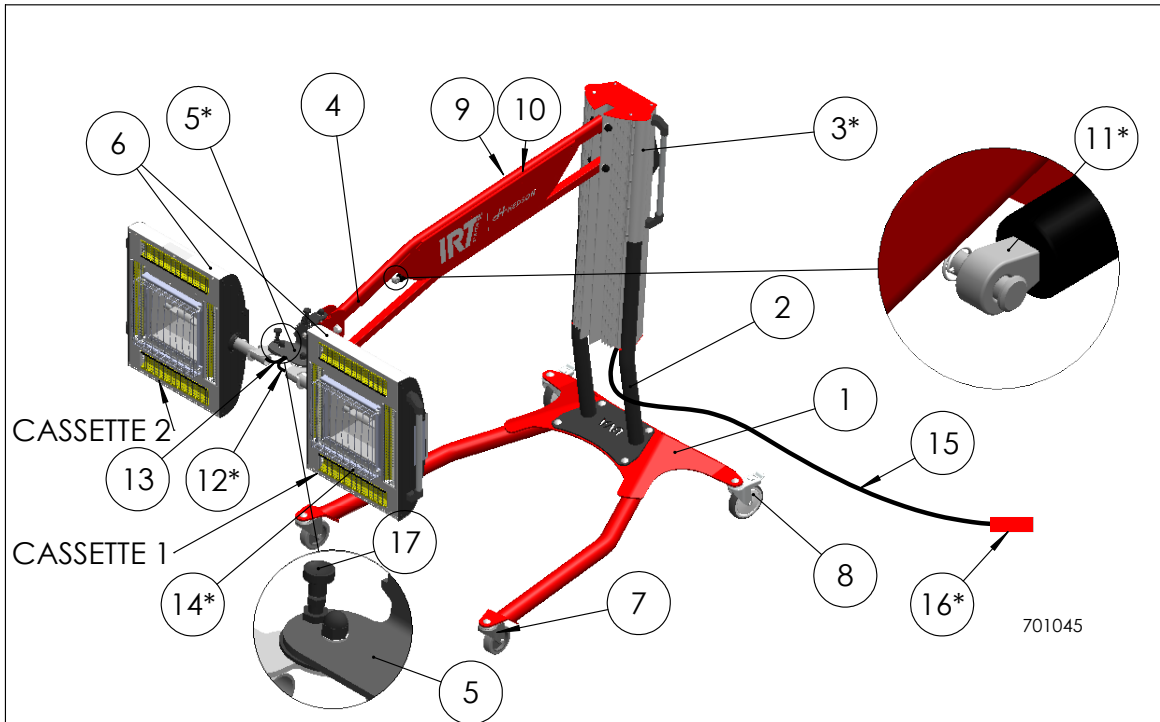

POS.	PART. NO.	DESCRIPTION
1	713472	FOOT
2	714455	PILLAR STAND (IRT 4-1/4-2 COMBI IR-UVA)
3	714973	CONTROL UNIT (IRT 4-1 COMBI IR-UVA)
3*	714986	CONTROL UNIT (IRT 4-2 COMBI IR-UVA)
3*	714984	CONTROL UNIT (IRT 4-20 COMBI IR-UVA)
4	713600	ARM COMPLETE (WITHOUT POS 9, 10 AND 11)
5	714835	CASSETTE ARM (IRT 4-1/4-10 COMBI IR-UVA)
5*	714736	CASSETTE ARM (IRT 4-2/4-20 COMBI IR-UVA)
6	714945	CASSETTE COMPLETE
7	410522	CASTOR DIA. 100mm
8	102258	CASTOR BRAKED 125mm
9	713783	PROTECTION PLATE RIGHT
10	713782	PROTECTION PLATE LEFT
11	714844	GASSPRING 1000N (IRT 4-1/4-10 COMBI IR-UVA)
11*	714845	GASSPRING 1600N (IRT 4-2/4-20 COMBI IR-UVA)
12	714879	HARNESS TO CASSETTE (IRT 4-1/4-10 COMBI IR-UVA)
12*	714874	HARNESS CASSETTE 1 (IRT 4-2/4-20 COMBI IR-UVA)
13	714875	HARNESS CASSETTE 2 (IRT 4-2/4-20 COMBI IR-UVA)
14	714839	PYROMETER KIT INCL LASER AND DISTANCE SENSOR (IRT 4-1/4-10 COMBI IR-UVA)
14*	714840	PYROMETER KIT INCL LASER AND DISTANCE SENSOR (IRT 4-2/4-20 COMBI IR-UVA)
15	711289	POWER CABLE 10m (IRT 4-1 COMBI IR-UVA)
15*	711291	POWER CABLE 10m (IRT 4-2 COMBI IR-UVA)
16	121677	POWER CONNECTOR (NEMA 15-20P IRT 4-1 COMBI IR-UVA)
16*	121678	POWER CONNECTOR (NEMA 15-30P IRT 4-2 COMBI IR-UVA)
17	120295	ADJUSTMENT BOLT

Material		Surface finish		Dimension		Note	
Drawn date	Approved by	Drawn by	Designed by	General Tolerance	Scale	Sheet	
2017-10-17	MF		AL	ISO 2768-m	1:20	1 (10)	
		Certified by				Status	
		Description				Article no	
		SPARE PART LIST MOBIL				Approved	
		230V 3PH NA				701045	
						Rev 1	

This document is the property of Hedson Technologies and may not be copied without our written permission. The contents thereof must not be imparted to a third party nor be used for any unauthorized purpose. Contravention will be prosecuted.

Den här ritning är Hedson Technologies egendom. Den får inte vara sig i ursprungligt eller ändrat skick utan vårt medgivande kopieras eller mångfaldigas, förvisas för eller på annat sätt delgivas eller utlämnas till tredje person. Överträdelse härav beivras med stöd av gällande lag

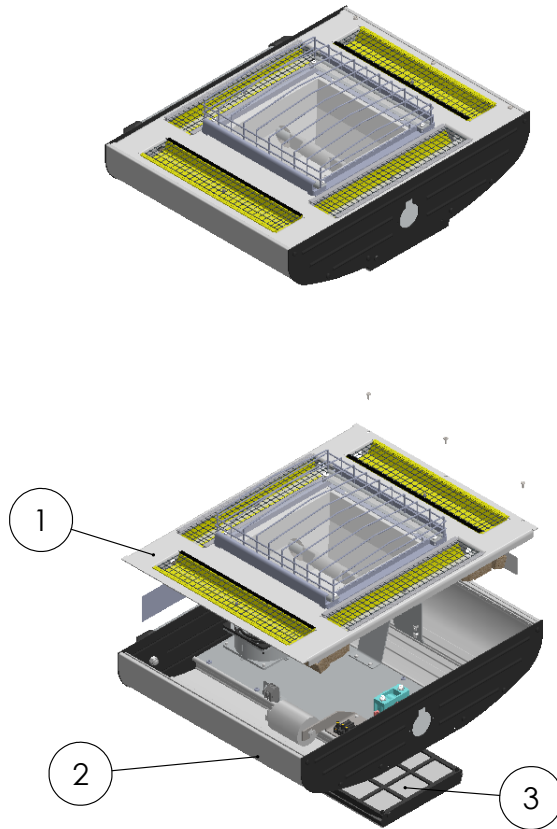

701045

POS.	PART NR.	DESCRIPTION
1	714948	CASSETTE FRONT COMPLETE
2	714946	CASSETTE BACK COMPLETE
3	713576	AIR FILTER

Material	Surface finish	Dimension	Note
Drawn date 2017-10-17	Approved by MF	Drawn by	Designed by AL
Certified by		General Tolerance ISO 2768-m	Scale 1:10
		Description SPARE PART LIST CASSETTE 230V 3PH NA	
		Status Approved	Sheet 2 (10)
		Article no 701045	Rev 1

This document is the property of Hedson Technologies and may not be copied without our written permission. The contents thereof must not be imparted to a third party nor be used for any unauthorized purpose. Contravention will be prosecuted.

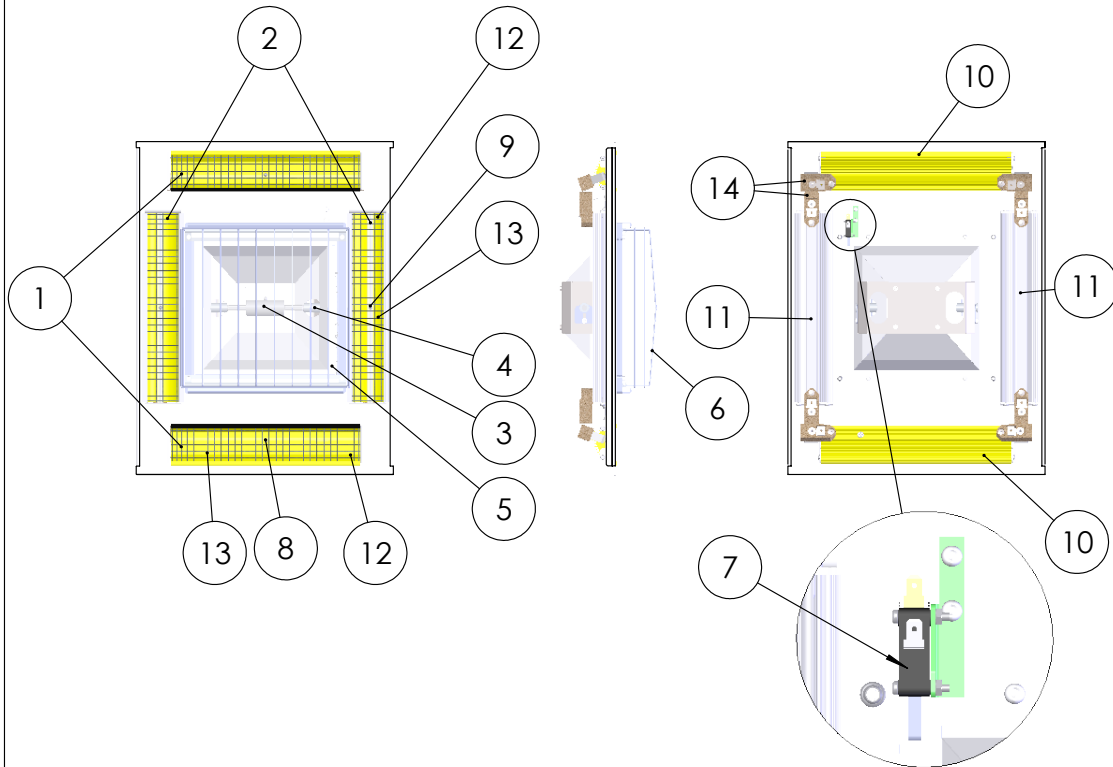

701045

Den här ritning är Hedson Technologies egendom. Den får inte vara sig i ursprungligt eller ändrat skick utan vårt medgivande kopieras eller mångfaldigas, förvisas för eller på annat sätt delgavs eller utlämnas till tredje person. Överträdelse här av beivras med stöd av gällande lag

POS.	PART.NO.	DESCRIPTION
1	713632	REFLECTOR FF1 1kW COMPLETE
2	713633	REFLECTOR FF2 2kW COMPLETE
3	714956	UV-LAMP REPLACEMENT KIT 230V NA
4	714917	UV LAMP HOLDER
5	714860	FILTER GLASS
6	714758	GRILLE
7	714753	SAFETY SWITCH FILTERGLAS
8	102700	IR LAMP 1kW
9	102699	IR-LAMP 2kW
10	713578	REFLECTOR FF1
11	713585	REFLECTOR FF2
12	104074	GOLD FOIL FF1/FF2
13	713801	PROTECTION MESH FF1/FF2
14	712393	IR LAMP HOLDER

Material		Surface finish		Dimension		Note	
Drawn date	Approved by	Drawn by	Designed by	General Tolerance	Scale	Sheet	
2017-10-17	MF		AL	ISO 2768-m	1:10	3 (10)	
		Certified by				Status	
		Description				Article no	
		SPARE PART LIST CASSETTE FRONT				Approved	
		230V 3PH NA				701045	
						Rev 1	

This document is the property of Hedson Technologies and may not be copied without our written permission. The contents thereof must not be imparted to a third party nor be used for any unauthorized purpose. Contravention will be prosecuted.

Den här ritning är Hedson Technologies egendom. Den får inte vara sig i ursprungligt eller ändrat skick utan vårt medgivande kopieras eller mångfaldigas, förvisas för eller på annat sätt delgavs eller utlämnas till tredje person. Överträdelse här av beivras med stöd av gällande lag

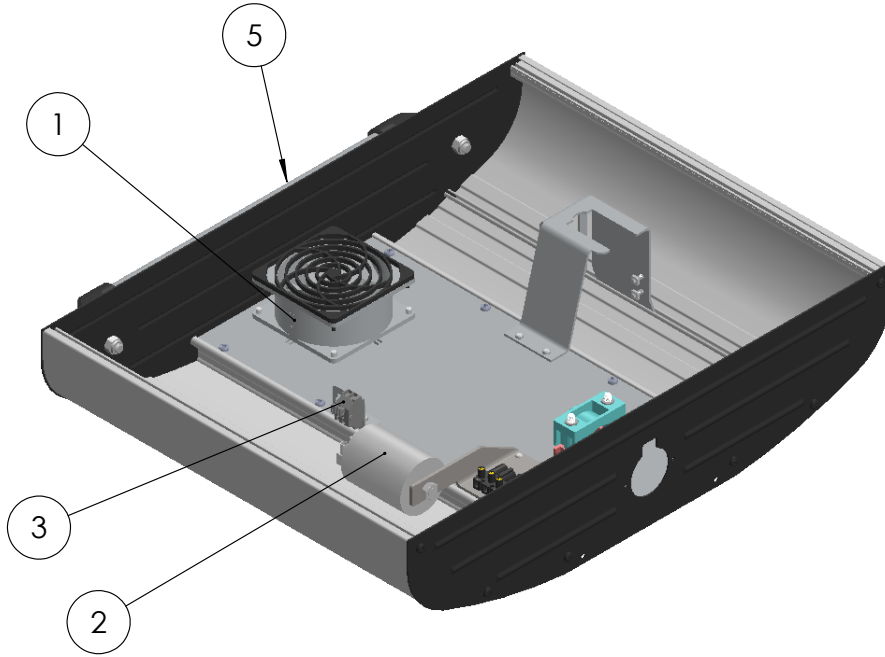

701045

POS.	PART.NR.	DESCRIPTION
1	714846	FAN WITH GRILLE
2	195804	IGNITER UV-LAMP
3	750692	INTERNAL WIRING KIT UV-LAMP
4	750705	INTERNAL WIRING KIT GLASSFILTER SAFETY SWITCH
5	713785	HANDLE

Material		Surface finish		Dimension		Note	
Drawn date 2017-10-17		Approved by MF		Designed by AL		General Tolerance ISO 2768-m	
Scale 1:5		Sheet 4 (10)		Certified by		Status Approved	
		Description SPARE PART LIST CASSETTE BACK 230V 3PH NA				Article no 701045	
		Rev 1					

This document is the property of Hedson Technologies and may not be copied without our written permission. The contents thereof must not be imparted to a third party nor be used for any unauthorized purpose. Contravention will be prosecuted.

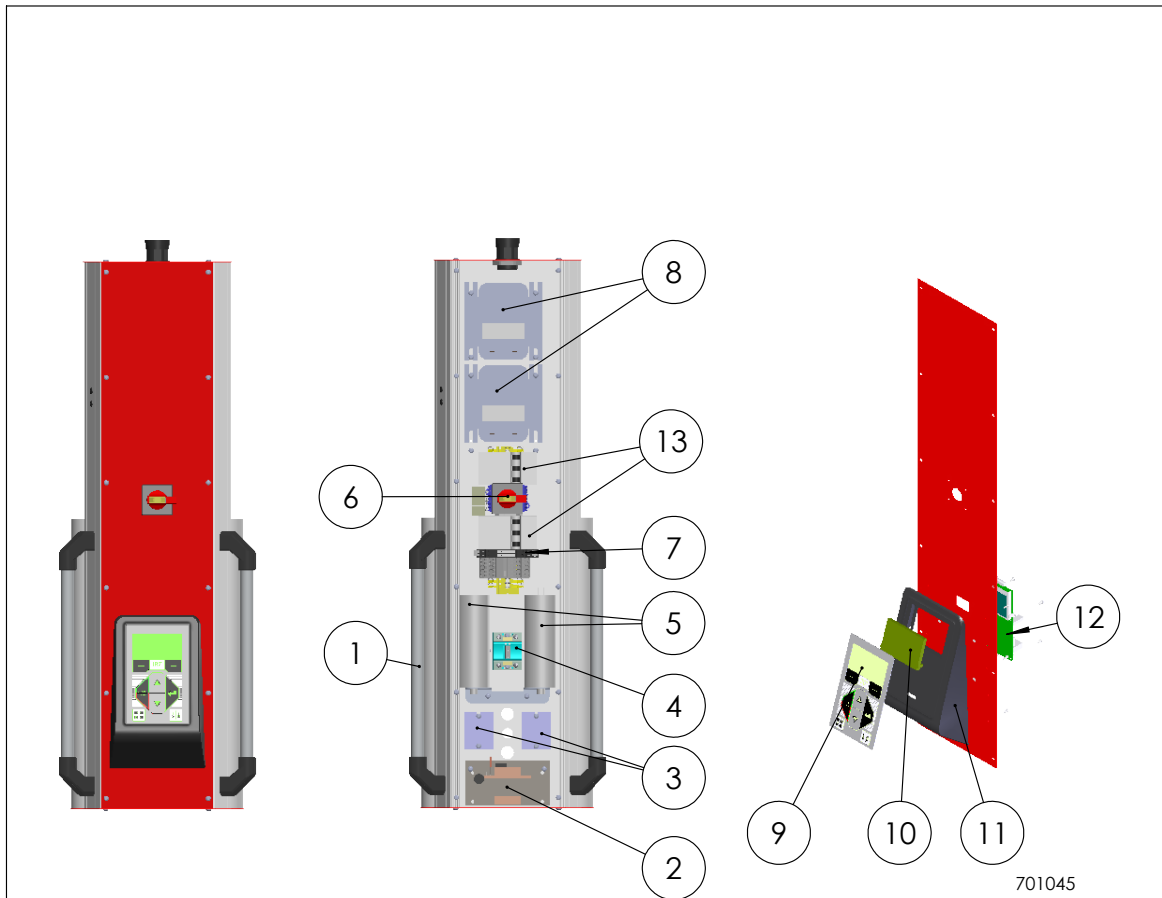

701045

Den här ritning är Hedson Technologies egendom. Den får inte vara sig i ursprungligt eller ändrat skick utan vårt medgivande kopieras eller mångfaldigas, förvisas för eller på annat sätt delgavs eller utlämnas till tredje person. Överträdelse här av beivras med stöd av gällande lag

POS.	PART.NO.	DESCRIPTION
1	713785	HANDLE
2	750300	TRANSFORMER
3	750227	SOLID STATE RELAY (IR)
4	193942	SOLID STATE RELAY (UV)
5	195671	CAPACITOR
6	713823	POWER BREAKER 32A
7	750433	RELAY (SAFETY SWITCH FILTER GLASS)
8	750721	BALLAST
9	750366	KEYBOARD
10	750220	DISPLAY
11	713755	DISPLAY UNIT COVER
12	750512	PCB IR/UV
13	126348	MCB (IRT 4-2/4-20 COMBI IR-UVA)

Material		Surface finish		Dimension		Note	
Drawn date	Approved by	Drawn by	Designed by	General Tolerance	Scale	Sheet	
2017-10-17	MF		AL	ISO 2768-m	1:10	5 (10)	
		Certified by				Status	
		Description				Article no	
		SPARE PART LIST CONTROL UNIT				701045	
		230V 3PH NA				Rev 1	

This document is the property of Hedson Technologies and may not be copied without our written permission. The contents thereof must not be imparted to a third party nor be used for any unauthorized purpose. Contravention will be prosecuted.

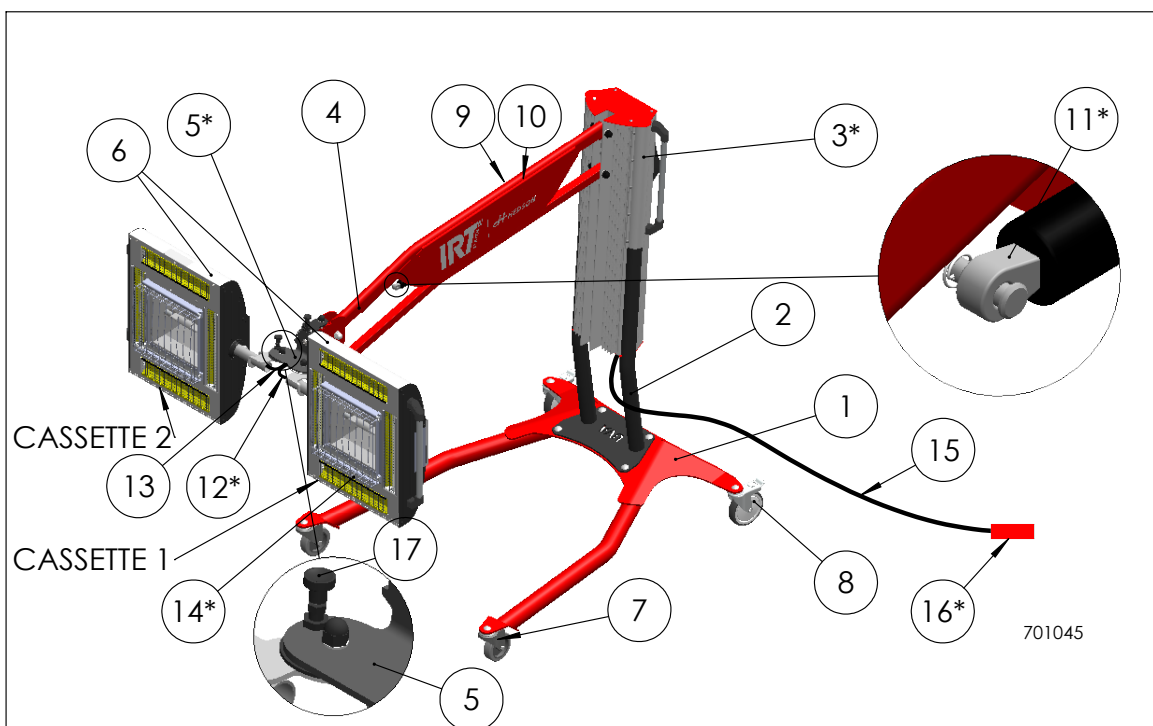

701045

Denna ritning är Hedson Technologies egendom. Den får icke vara sig i ursprungligt eller ändrat skick utan vårt medgivande kopieras eller mångfaldigas förvisas för eller på annat sätt delgivas eller utlämnas till tredje person. Överträdelse härav beivras med stöd av gällande lag

POS.	PART. NO.	DESCRIPTION
1	713472	FOOT
2	714455	PILLAR STAND (IRT 4-1/4-2 COMBI IR-UVA)
3	714963	CONTROL UNIT (IRT 4-1 COMBI IR-UVA)
3*	714962	CONTROL UNIT (IRT 4-2 COMBI IR-UVA)
4	713600	ARM COMPLETE (WITHOUT POS 9, 10 AND 11)
5	714835	CASSETTE ARM (IRT 4-1/4-10 COMBI IR-UVA)
5*	714736	CASSETTE ARM (IRT 4-2/4-20 COMBI IR-UVA)
6	714968	CASSETTE COMPLETE
7	410522	CASTOR DIA. 100mm
8	102258	CASTOR BRAKED 125mm
9	713783	PROTECTION PLATE RIGHT
10	713782	PROTECTION PLATE LEFT
11	714844	GASSPRING 1000N (IRT 4-1/4-10 COMBI IR-UVA)
11*	714845	GASSPRING 1600N (IRT 4-2/4-20 COMBI IR-UVA)
12	714985	HARNESS TO CASSETTE (IRT 4-1/4-10 COMBI IR-UVA)
12*	714961	HARNESS CASSETTE 1 (IRT 4-2/4-20 COMBI IR-UVA)
13	714962	HARNESS CASSETTE 2 (IRT 4-2/4-20 COMBI IR-UVA)
14	714839	PYROMETER KIT INCL LASER AND DISTANCE SENSOR (IRT 4-1/4-10 COMBI IR-UVA)
14*	714840	PYROMETER KIT INCL LASER AND DISTANCE SENSOR (IRT 4-2/4-20 COMBI IR-UVA)
15	711290	POWER CABLE 10m (IRT 4-1 COMBI IR-UVA)
15*	712167	POWER CABLE 5m (IRT 4-2 COMBI IR-UVA)
16	122825	POWER CONNECTOR (NEMA 6-30P IRT 4-1 COMBI IR-UVA)
16*	121833	POWER CONNECTOR (NEMA 6-50P IRT 4-2 COMBI IR-UVA)
17	120295	ADJUSTMENT BOLT

Material		Surface finish		Dimension		Note	
Drawn date 2017-10-17		Approved by MF		Designed by AL		General Tolerance ISO 2768-m	
		Certified by		Scale 1:20		Sheet 6 (10)	
		Description SPARE PART LIST MOBIL 230V 1PH NA				Status Approved	
						Article no 701045	
						Rev 1	

This document is the property of Hedson Technologies and may not be copied without our written permission. The contents thereof must not be imparted to a third party nor be used for any unauthorized purpose. Contravention will be prosecuted.

Den här ritning är Hedson Technologies egendom. Den får inte vara sig i ursprungligt eller ändrat skick utan vårt medgivande kopieras eller mångfaldigas, förvisas för eller på annat sätt delgavs eller utlämnas till tredje person. Överträdelse här av beivras med stöd av gällande lag

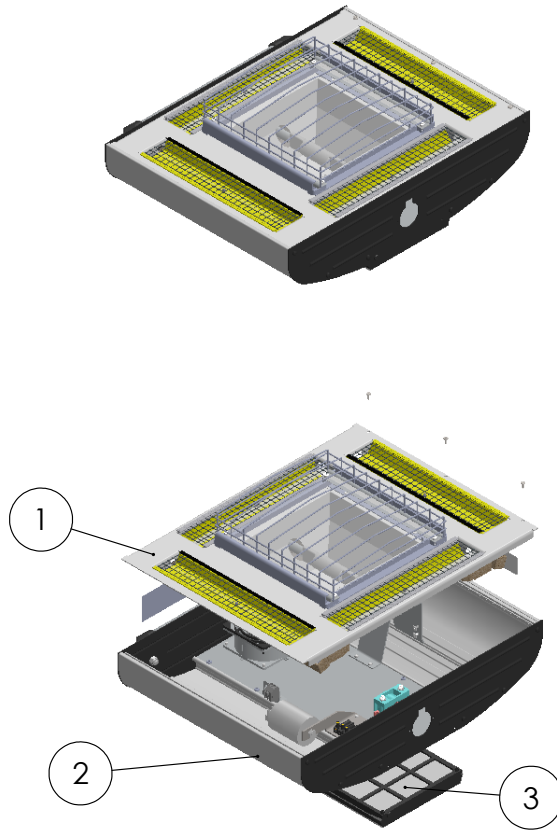

701045

POS.	PART.NR.	DESCRIPTION
1	714969	CASSETTE FRONT COMPLETE
2	714946	CASSETTE BACK COMPLETE
3	713576	AIR FILTER

Material	Surface finish	Dimension	Note
Drawn date 2017-10-17	Approved by MF	Drawn by	Designed by AL
Certified by		General Tolerance ISO 2768-m	Scale 1:10
		Description SPARE PART LIST CASSETTE 230V 1PH NA	
		Status Approved	Sheet 7 (10)
		Article no 701045	Rev 1

This document is the property of Hedson Technologies and may not be copied without our written permission. The contents thereof must not be imparted to a third party nor be used for any unauthorized purpose. Contravention will be prosecuted.

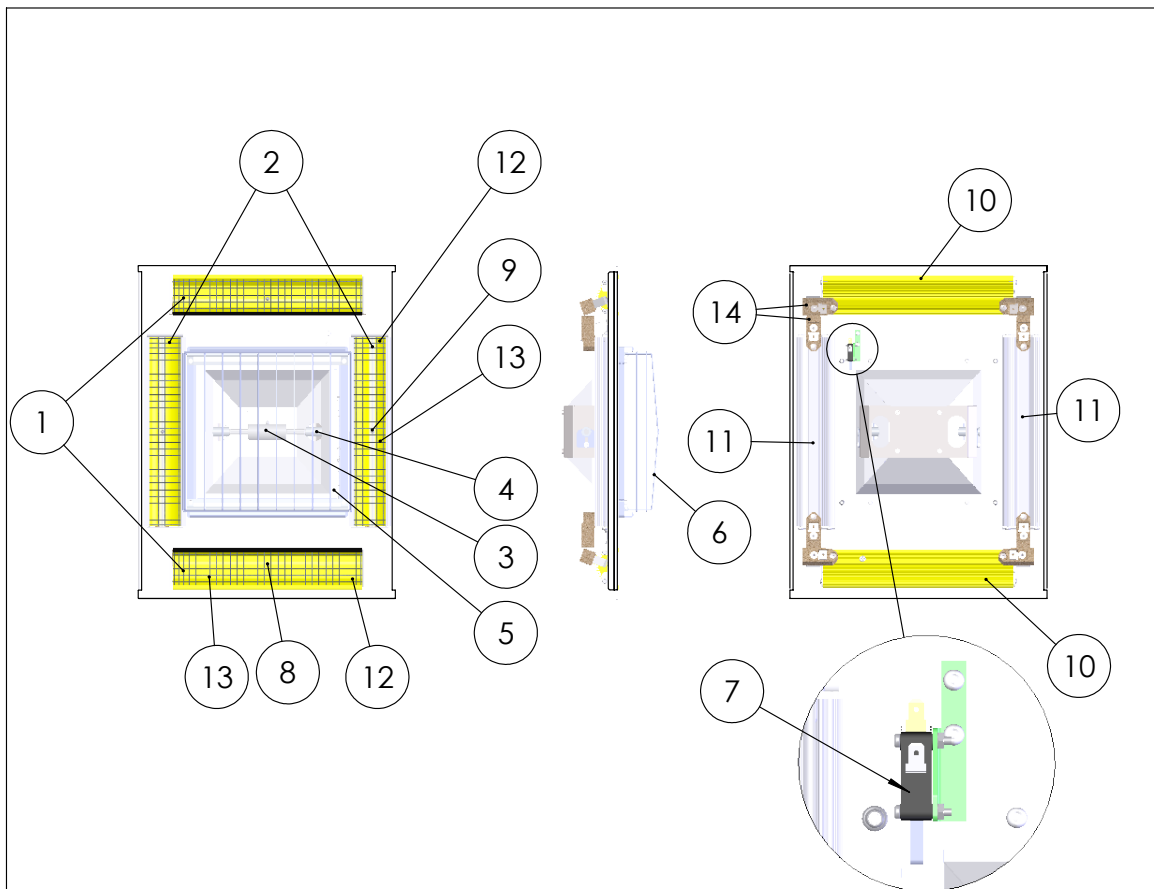

701045

Den här ritning är Hedson Technologies egendom. Den får inte vara sig i ursprungligt eller ändrat skick utan vårt medgivande kopieras eller mångfaldigas, förvisas för eller på annat sätt delgivas eller utlämnas till tredje person. Överträdelse här av beivras med stöd av gällande lag

POS.	PART.NO.	DESCRIPTION
1	713632	REFLECTOR FF1 1kW COMPLETE
2	713633	REFLECTOR FF2 2kW COMPLETE
3	714956	UV-LAMP REPLACEMENT KIT 230V NA
4	714917	UV LAMP HOLDER
5	714860	FILTER GLASS
6	714758	GRILLE
7	714753	SAFETY SWITCH FILTERGLAS
8	102700	IR LAMP 1kW
9	102699	IR-LAMP 2kW
10	713578	REFLECTOR FF1
11	713585	REFLECTOR FF2
12	104074	GOLD FOIL FF1/FF2
13	713801	PROTECTION MESH FF1/FF2
14	712393	IR LAMP HOLDER

Material		Surface finish		Dimension		Note	
Drawn date	Approved by	Drawn by	Designed by	General Tolerance	Scale	Sheet	
2017-10-17	MF		AL	ISO 2768-m	1:10	8 (10)	
		Certified by				Status	
		Description				Article no	
SPARE PART LIST CASSETTE FRONT				701045		Approved	
230V 1PH NA						Rev 1	

This document is the property of Hedson Technologies and may not be copied without our written permission. The contents thereof must not be imparted to a third party nor be used for any unauthorized purpose. Contravention will be prosecuted.

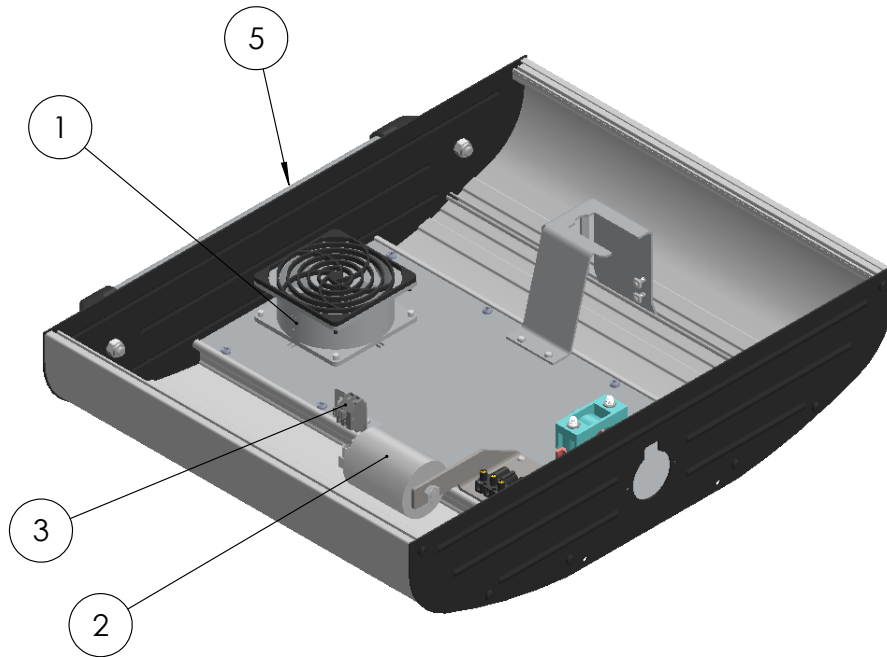

701045

Denne ritning är Hedson Technologies egendom. Den får inte vara sig i ursprungligt eller ändrat skick utan vårt medgivande kopieras eller mångfaldigas, förvisas för eller på annat sätt delgivas eller utlämnas till tredje person. Överträdelse här av beivras med stöd av gällande lag

POS.	PART.NR.	DESCRIPTION
1	714846	FAN WITH GRILLE
2	195804	IGNITER UV-LAMP
3	750692	INTERNAL WIRING KIT UV-LAMP
4	750705	INTERNAL WIRING KIT GLASSFILTER SAFETY SWITCH
5	713785	HANDLE

Material		Surface finish		Dimension		Note	
Drawn date 2017-10-17		Approved by MF		Designed by AL		General Tolerance ISO 2768-m	
Scale 1:5		Sheet 9 (10)		Certified by		Status Approved	
		Description SPARE PART LIST CASSETTE BACK 230V 1PH NA				Article no 701045	
		Rev 1					

This document is the property of Hedson Technologies and may not be copied without our written permission. The contents thereof must not be imparted to a third party nor be used for any unauthorized purpose. Contravention will be prosecuted.

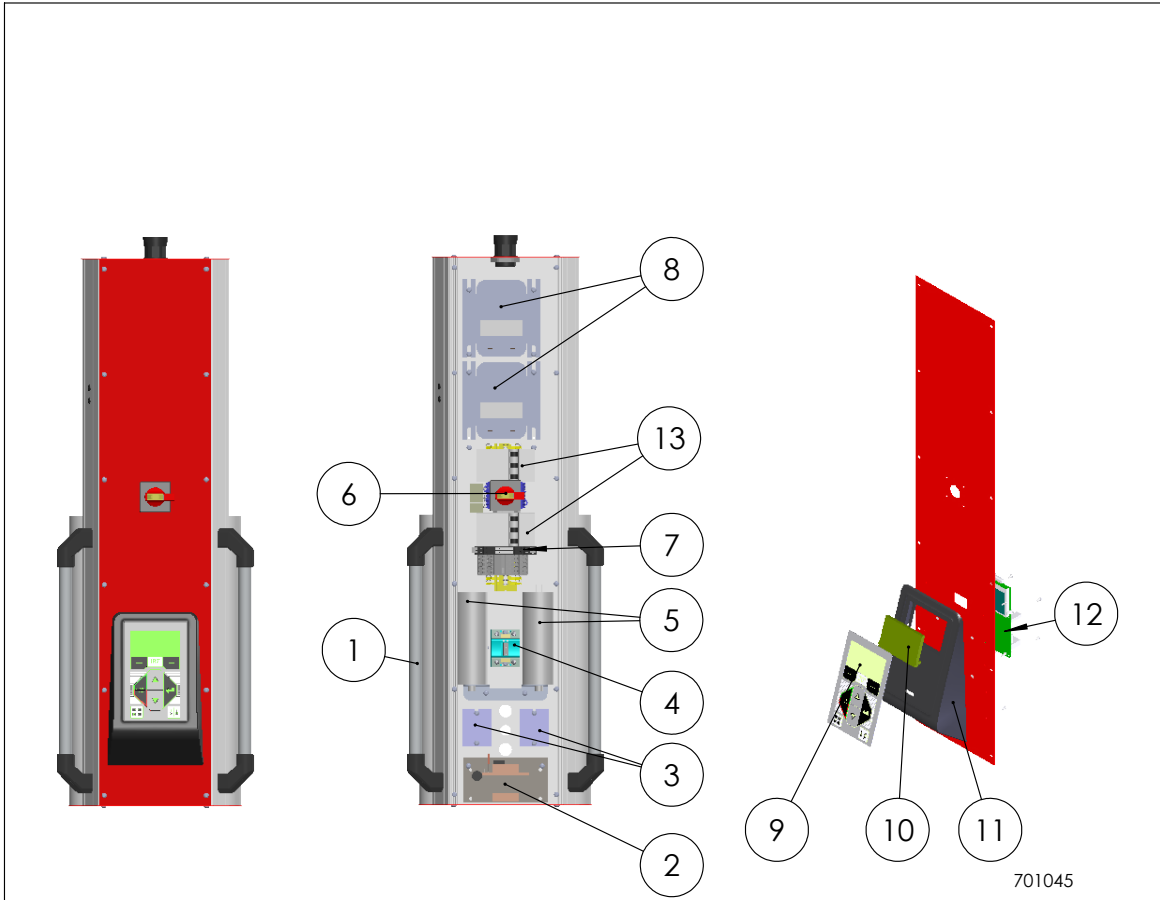

701045

Den här ritning är Hedson Technologies egendom. Den får inte vara sig i ursprungligt eller ändrat skick utan vårt medgivande kopieras eller mångfaldigas, förvisas för eller på annat sätt delgavs eller utlämnas till tredje person. Överträdelse här av beivras med stöd av gällande lag

POS.	PART.NO.	DESCRIPTION
1	713785	HANDLE
2	750300	TRANSFORMER
3	750227	SOLID STATE RELAY (IR)
4	193942	SOLID STATE RELAY (UV)
5	195671	CAPACITOR
6	713823	POWER BREAKER 32A (IRT 4-1 COMBI IR-UVA)
6*	713824	POWER BREAKER 63A (IRT 4-2 COMBI IR-UVA)
7	750433	RELAY (SAFETY SWITCH FILTER GLASS)
8	750721	BALLAST
9	750366	KEYBOARD
10	750220	DISPLAY
11	713755	DISPLAY UNIT COVER
12	750512	PCB IR/UV
13	126350	MCB (IRT 4-2/4-20 COMBI IR-UVA)

Material		Surface finish		Dimension		Note	
Drawn date	Approved by	Drawn by	Designed by	General Tolerance	Scale	Sheet	
2017-10-17	MF		AL	ISO 2768-m	1:10	10 (10)	
		Certified by				Status	
		Description				Article no	
		SPARE PART LIST CONTROL UNIT				701045	
		230V 1PH NA				Rev 1	

15. Weights and dimensions

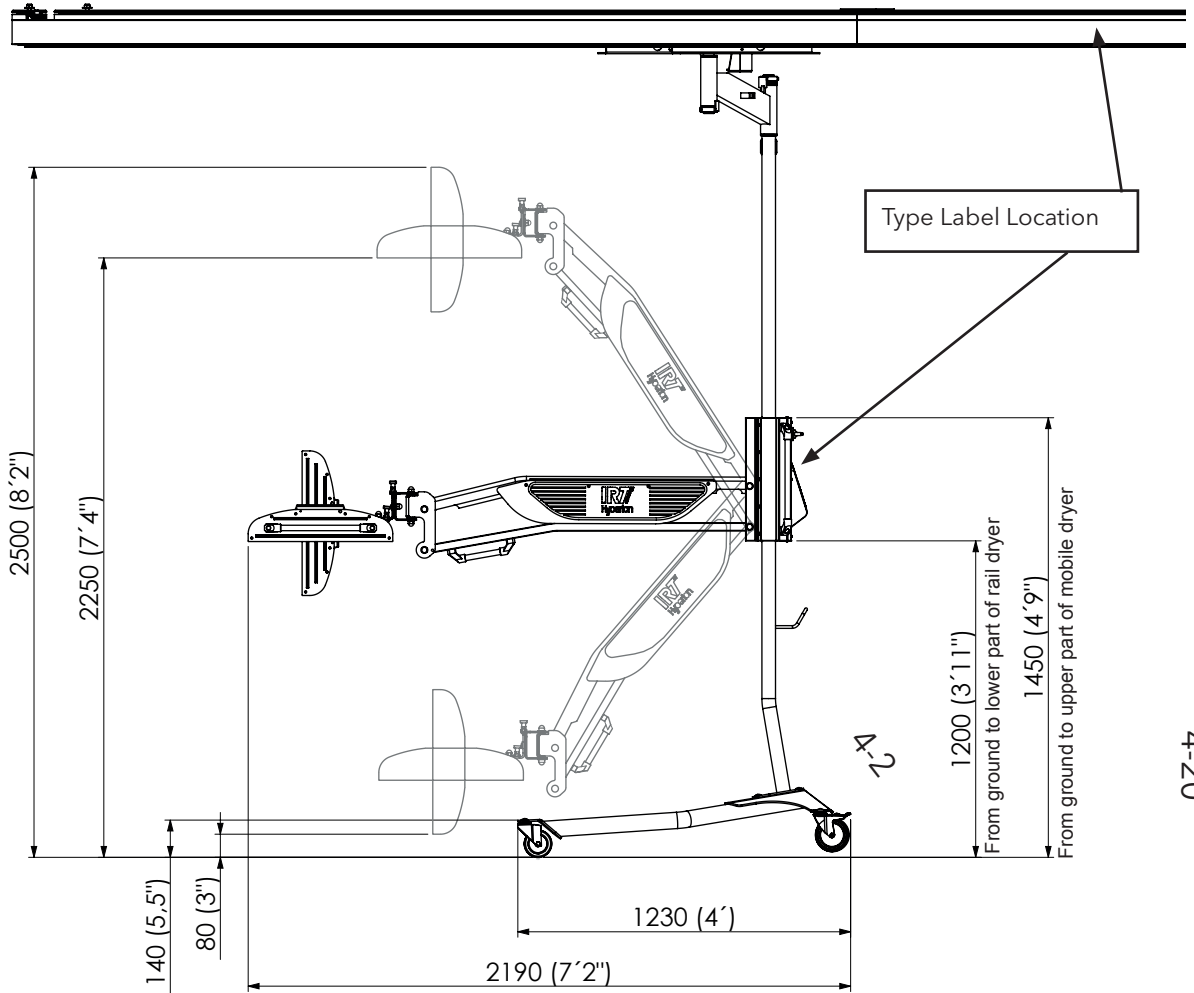

4-20

Weight

IRT COMBI 4-1 IR/UVA 70 kg

IRT COMBI 4-2 IR/UVA 85 kg

Assembly manual 714838

© Hedson Technologies N.A. Inc 2017
The manufacturer reserves the right to introduce technical modifications.



Intertek



— PERFORMANCE ABOVE ALL —

Hedson Technologies AB
Hammarvägen 4
232 37 ARLÖV, Sweden
Tel. +46 40 53 42 00
info@hedson.com
www.hedson.com

Hedson Technologies N.A. Inc
Phone 1-866-IRT-HEAT (478-4328)
www.hedsonna.com
sales@hedsonna.com