

IRT-UVA 1/2 PrepCure 4 Digital



TABLE OF CONTENTS

Safety instructions.....	3
1. Intended use of the product	4
2. Product description	4
3. Technical data	4
4. Instruction to the owner.....	4
5. Markings	5
6. Operation	5
7. Maintenance.....	5
8. Filter replacement.....	6
9. UV-lamp replacement	6
10. Trouble shooting.....	6
11. Declaration of conformity	6
12. Spare parts list.....	7
13. Electrical Diagram.....	8
14. Dimensions	10

IMPORTANT SAFETY INSTRUCTIONS

When using an electrical equipment, basic precautions should always be followed, including the following:

READ ALL INSTRUCTIONS BEFORE USING IRT-UVA 1/2 Prep-Cure 4 Digital



UV RADIATION CAN CAUSE PERSONAL INJURY AND PROPERTY DAMAGE!

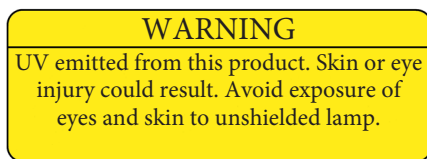

To reduce risk of injury, or property damage from UV radiation, read, understand, and follow the following safety instructions. In addition, make certain that anyone else that uses this heating equipment follows these safety instructions as well.

- The Equipment emits more than 0.1 $\mu\text{W}/\text{cm}^2$ and shall only be used in locations where access to the equipment and the emissions is restricted to qualified personnel.

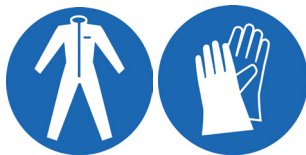

- *Wear protective clothing.* Hands, face and other parts of the body shall not be exposed to heat and radiation. Do not stay in front of the lamp cassettes during curing without safety equipment.



- Always wear eye protection. Failure to this may result in longterm injury to the eyes.
- If a person works around UV radiation while on medications, the medication should be checked to see if it would make the person more photosensitive.
- Do not look directly at the light source.
- Do not use if protective glass is broken or missing. This glass filters the light from unwanted radiation.



To reduce the risk of fire, electric shock, or injury:

- Do not leave equipment when plugged in. Unplug from outlet when not in use and before servicing.
- Do not allow to be used as a toy. Close attention is necessary when used by or near children.
- Use only as described in this manual. Use only manufacturer's recommended attachments.
- Do not use with damaged cord or plug. If equipment is not working as it should, has been dropped, damaged, left outdoors, or dropped into water, return it to a service center.
- Do not pull or carry by cord, use cord as a handle, close a door on cord, or pull cord around sharp edges or corners. Do not run equipment over cord. Keep cord away from heated surfaces.
- Do not unplug by pulling on cord. To unplug, grasp the plug, not the cord.
- Do not handle plug or equipment with wet hands.
- Turn off all controls before unplugging.
- Do not store, prepare or use solvent-containing materials within a 5 m/16 feet radius of the mobile dryer.
- Flammable materials should not be placed close to a drying device in use.
- Never direct the cassette towards highly combustible materials.
- The dryer must not be exposed to paint fog, sanding dust or solvents, due to fire and explosion risk. Furthermore, the lifetime of the dryer will otherwise be reduced.
- Allow for sufficient cooling time of the dryer.
- The mobile dryer is operated by highly dangerous electrical voltage.
- Before accessing live parts, remove the main connector from the wall socket. Only professional electricians may have direct access into the electrical equipment.
- If the supply cord is damaged, it must be replaced by the manufacturer, its service agent or similarly qualified persons in order to avoid a hazard.



Hot surface

The filter glass in front of the UV-lamp can become very hot and has a long cooling down time after operation.

SAVE THESE INSTRUCTIONS

1. Intended use of the product

This product serves exclusively to accelerate the curing of putty, filler, base and clear coats. The product must not be used for other purposes than the described curing processes.

This product should only be used with the filter glass intact.

A missing or broken filter glass will result in hazardous UVC and UVB radiation. For a worker working close to the operating lamp (1,5m) the daily limitation should be set to 1h/working day.

Only original spare parts shall be used to maintain this products high safety.

The Equipment emits more than 0.1 $\mu\text{W}/\text{cm}^2$ and shall only be used in locations where access to the equipment and the radiated emissions is restricted to qualified personnel.

The maximum ambient temperature during operation should not exceed 40°C.

Do not use the product in spray booths or within a distance of 5 m from other solvent based spraying activities in order to avoid explosion risks.

2. Product description

The easily manoeuvrable IRT-UVA PrepCure is equipped with one or two cassettes. The cassette is equipped with high efficiency UVA-lamps (1150 / 2300 W) which makes the curing extremely fast. The time can be set to 0-15 min.

UV curing

The ultraviolet light spectrum generated by a UV lamp interacts with special coating chemistries to produce a high-quality, durable curing. In many applications, UV curing can achieve the curing faster and therefore at a lower total cost than many other coating processes.

UV-coat contains less solvent than conventional paint and from that perspective has less negative environmental impact.

Most importantly to achieve a good and fast curing result there must be enough UV-A intensity. IRT UVA PrepCure has an outstanding intensity to achieve the best curing result.

Unique benefits of the UV cure coating

- Reduced amount of solvent
- Fast curing time
- Low-temperature processing
- Scratch resistant and chemical resistant

3. Technical data

Curing area

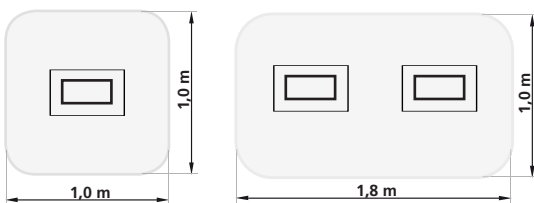

Curing area at 50 cm distance for a UVA 1 is 1,0x1,0 m (height x width) with an UV-A intensity of 15 W/m² at the outer edges and up to 100 W/m² at the center of the curing area. Curing area at 50 cm distance for a UVA-2 is 1,0 x 1,8 m (height x width) with an UV-A intensity of 15-100W/m².

Consult your paint supplier to find out what intensity your paint material needs.

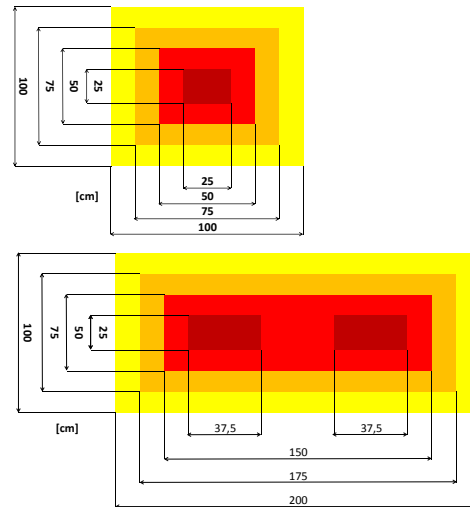

Intensity (W/m²):

	50 cm distance	35 cm distance
Yellow	15-46	15-46
Orange	31-73	62-146
Red	51-82	102-164
Dark Red	65-100	130-200

IRT-UVA-1/2 PrepCure 4 Digital is in excess of the Exempt Group and viewer-related risk is depending upon the use of the product.

	IRT-UVA-1 PrepCure 4	IRT-UVA-2 PrepCure 4
Voltage	230 V 1 ~/PE	
Frequency	50-60 Hz	
Current	5 A	10 A
Recommended fuse	15A	
H.I.D. UV bulb light	High pressure metal halide lamp	
Lamp wattage	1,15 kW	2,3 kW
Noise level	< 70 dB (A)	
Risk Group ANSI/IESNA RP27.3-07:	3 (RG-3)	

4. Instruction to the owner

The owner of the mobile dryer must produce clear operating instructions, adapted to local site conditions, and make these available to all users.

Mobile dryer users must adhere to these operating instructions.

This appliance is not intended for use by persons (including children) with reduced physical, sensory or mental capabilities, or lack of experience and knowledge, unless they have been given supervision or instruction concerning use of the appliance by a person responsible for their safety.

This product should only be used with the filter glass intact. A missing or broken filter glass will result in hazardous UVC and UVB radiation. For a worker working close to the operating lamp (1,5m) the daily limitation should be set to 1h/working day.

Only original spare parts shall be used to maintain this products high safety.

Dispose of spent items at the nearest environmental

protection facility for recycling.

The UV- radiation emission is: according to ANSI/IESNA RP27.3-07 = Ris Group 3 (RG-3)

As appropriate measures; Always wear eye protection during work in areas exposed to UV-radiation.

The lamp used in IRT UV-equipment have a spectrum that start below 250nm but is of an ozone free type. To ensure that the possible concentration of ozone is at a safe value make sure to always work in a well-ventilated environment.

5. Markings

Markings on control unit:



714485 Warning! UV RADIATION CAN CAUSE INJURY AND PROPERTY DAMAGE! Always wear eye protection, gloves and protective clothing.

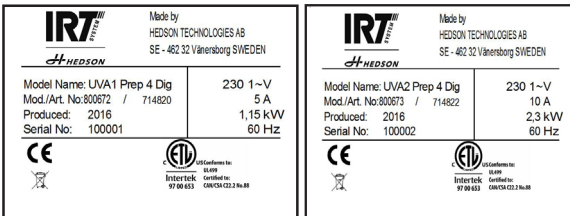

Machine sign

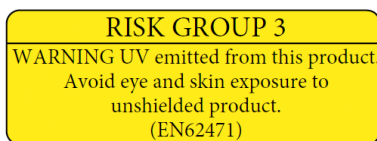

714526 WARNING UV emitted from this product. Avoid eye and skin exposure to unshielded product.

Markings on cassette:

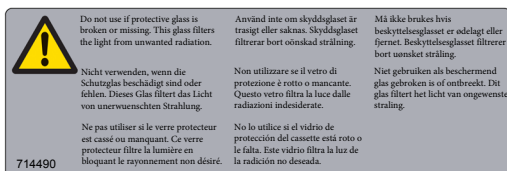

714490 Do not use if protective glass is broken or missing. This glass filters the light from unwanted radiation.

WARNING Eye damage may result from directly viewing the light produced by the lamp in this apparatus. Always turn off the lamp before opening this cover.

For replacement of lamp follow the instruction included in the UV-lamp replacement kit, part number 714927.

714852

714852 WARNING Eye damage may result from directly viewing the light produced by the lamp of this apparatus. For replacement of lamp follow the instruction included in the UV-lamp replacement kit, part number 714927.



410606 (Hot surface)

6. Operation

Turn the main switch on.

Set the timer to the recommended time by pressing (+) or (-) buttons. To start the unit, press the Start/Stop button. Also press Start/Stop button for an earlier termination of the curing.

To see the remaining life time of the UV-lamps select one of the lamps according to above and then press the button with the percent sign (%).

NOTE: The restart of a hot lamp normally takes 4-6 minutes pending on the duration time in the recent performed curing.

NOTE: When the curing process is terminated, do not turn off the main switch before the cassette has, by the fan, cooled down for about 5 minutes. Switching off the dryer too early will shorten the lifetime of the UVA-lamps.

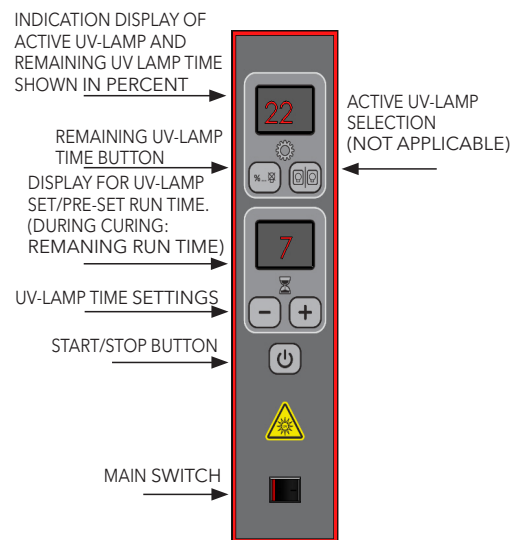

7. Maintenance

Before every usage,

check that:

- external cabling is not damaged
- protection glass in front of lamp is not cracked or removed
- protection glass is clean and free from spray fog that decreases the intensity

Weekly

Check that UV lamps light up during mobile dryer operation. Also, check that all cables are undamaged. A damaged cable can be a danger to life!

Quarterly

Change the air filter at least once per quarter. If the outer surface of the filter becomes very dirty, it must be changed sooner.

8. Filter replacement

1. Loosen the metal clips on the side plates of the cassette.
2. Remove the used filter.
3. Insert the new filter in such a way that the IRT logo is visible from the outside.
4. Push the long edges of the filter into the cassette grooves.
5. Replace the metal clips.

Attention: The filters are disposable and so should not be cleaned as this will result in the loss of their filtering capacity.

9. UV-lamp replacement

Please contact your distributor and order a UV-lamp replacement kit including instructions. After replacing the lamp a reset of the timer needs to be done.



Reset Lamp timer:

Make sure that the main switch [5] is turned off. Hold the Start/Stop button [1] and top right button [2] pressed in simultaneously while the main switch [5] is turned on. Keep the buttons pressed in until a confirmation message (L1--rESEt.) appears in the top display [4].

11. Declaration of conformity

We, Hedson Technologies AB
Box 1530
SE-462 28 VÄNERSBORG Sweden

declare under our sole responsibility that the product IRT-UVA 1/2 PrepCure 4 Digital

to which this declaration relates is in conformity to the applicable provisions of US Federal requirements, including the Code of Federal Regulations, CFR Title 21, --FOOD AND DRUGS CHAPTER I--FOOD AND DRUG ADMINISTRATION DEPARTMENT OF HEALTH AND HUMAN SERVICES SUBCHAPTER J--RADIOLOGICAL HEALTH.

UV-curing devices is not included in table 1 of 21 CFR 1002.1 and therefore not subject to a mandatory radiation safety performance standard contained in title 21 CFR Part 1040 (optical radiation) but complies with the general requirements in Title 21 CFR 1000 through 1005.

following the standards:

UL499 14th Ed. issued Nov. 7, 2014.
CSA C22.2 No.88 issued: 1958/09/01

Arlöv, Sweden, July 2016

HEDSON TECHNOLOGIES AB
Technology Division
Magnus Björnström
Magnus Björnström

CEO

10. Trouble shooting

Problem

The UVA lamps starts up but shuts down automatically after a while.

Possible solution

The lamp is worn out. Please contact your distributor and order a new one.

Problem

The lamp doesn't start.

Possible solutions:

- Ensure that required cooling time for lamps is fulfilled. Cooling time increases with dirty air filter.
- The lamp is worn out. Please contact your distributor and order a new lamp.
- Filter glass is broken.
- No power in wall socket, check fuse.

12. Spare parts list

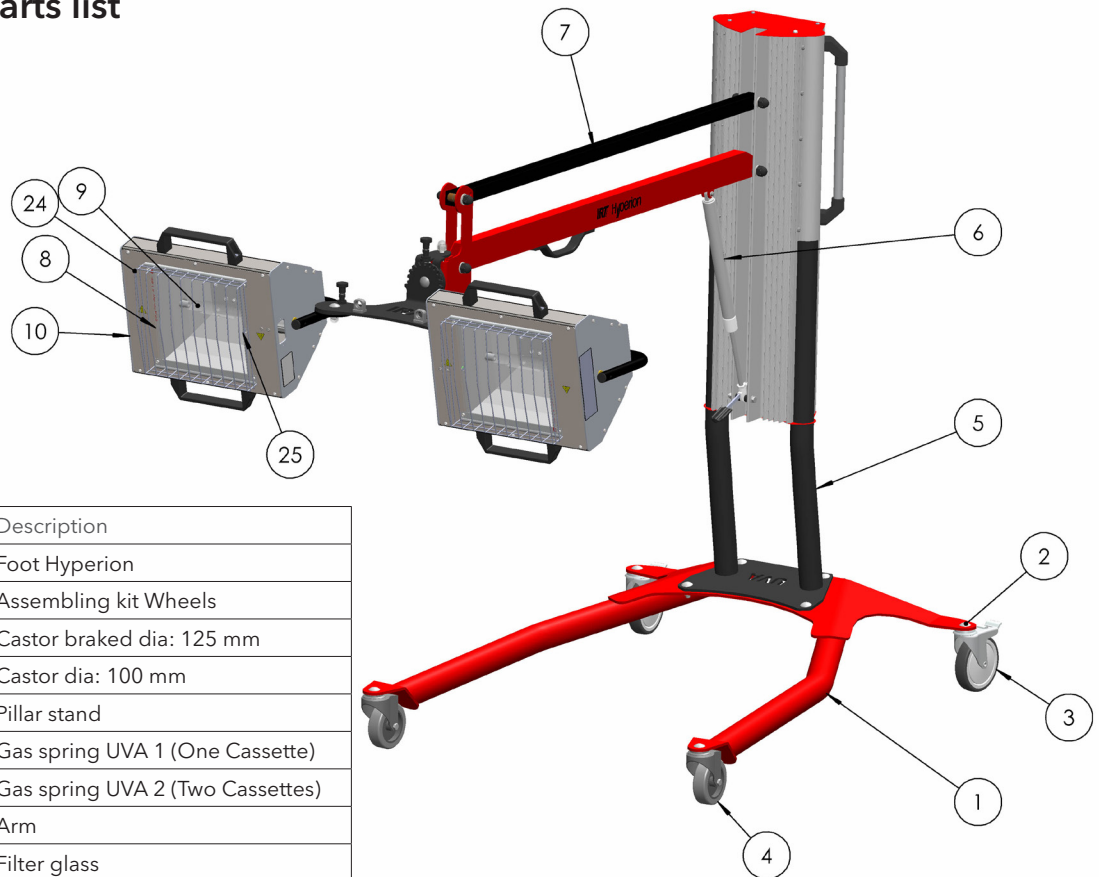

Pos.	Part.no	Description
1	713472	Foot Hyperion
2	714156	Assembling kit Wheels
3	102258	Castor braked dia: 125 mm
4	410522	Castor dia: 100 mm
5	714455	Pillar stand
6	714471	Gas spring UVA 1 (One Cassette)
6*	714472	Gas spring UVA 2 (Two Cassettes)
7	714456	Arm
8	714860	Filter glass
9	714927	UV-Lamp replacement kit
10	714750	Complete cassette
11	714914	Complete control unit UVA 1 (One Cassette)
11*	714916	Complete control unit UVA 2 (Two Cassettes)
12	750682	Harness, control unit to cassette (not in picture)
13	750607	Cordset (not in picture)
14	195804	Igniter (not in picture)
15	712894	Filter (not in picture)
16	714622	Filter Clip (not in picture)
17	750721	Ballast
18	195671	Capacitor
19	193942	Solid state relay
20	750500	Overlay
21	750650	Circuit board (Note! In order add comment; Single or double cassette coded)
22	420771	Main switch
23	129070	UV-protection glasses (not in picture)
24	714758	Protection net
25	714799	Safety switch filter glass
26	714924	Cooling fan (not in picture)

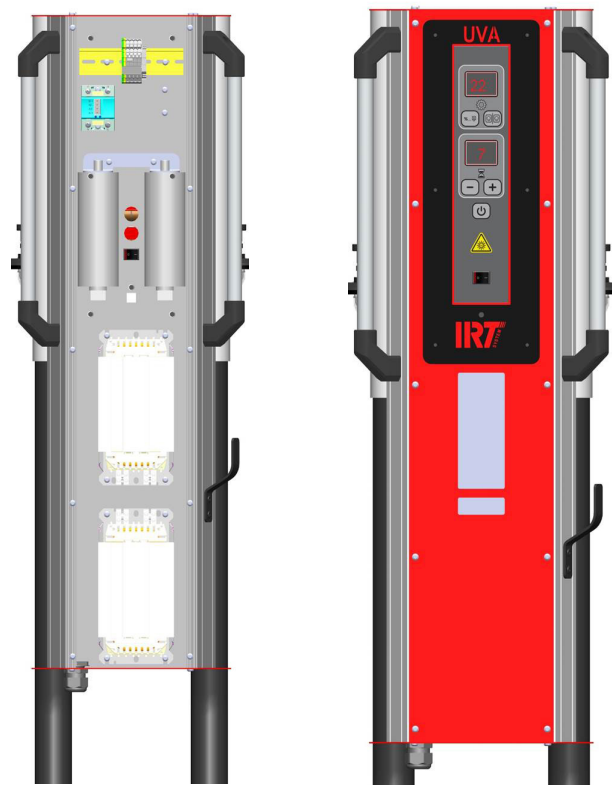

*) Option

13. Electrical Diagram

IRT UVA-1 PrepCure 4 230V 1 phase

THE INFORMATION CONTAINED HEREIN IS PROPRIETARY TO HEDSON TECHNOLOGIES AB AND IS NOT TO BE REPRODUCED, COMMUNICATED TO A THIRD PERSON, OR USED WITHOUT THE EXPRESS WRITTEN PERMISSION OF HEDSON TECHNOLOGIES AB.

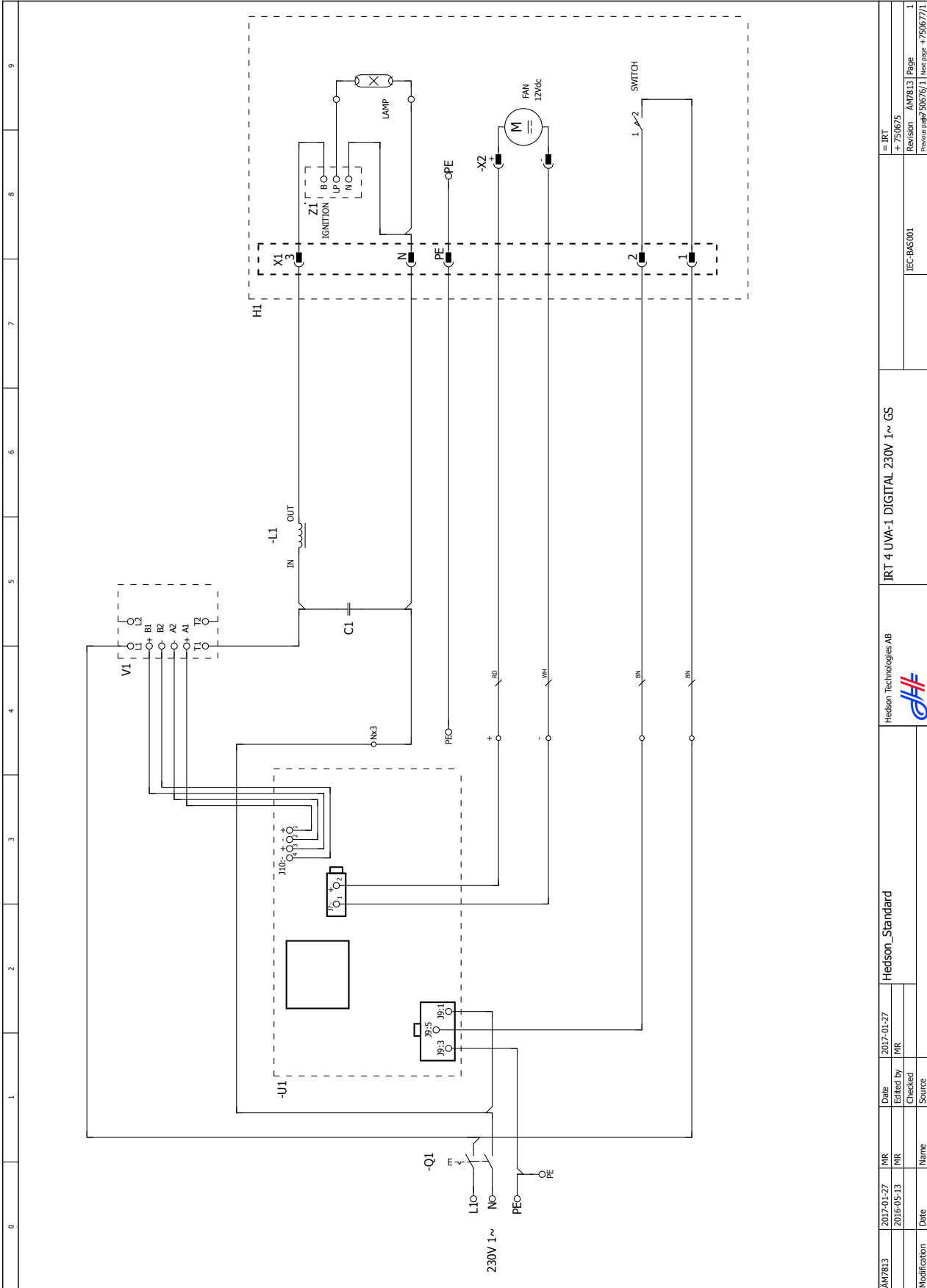

AM7813	2017-01-27	MR	2017-01-27	Hedson_Standard		IRT 4 UVA-1 DIGITAL 230V 1~ GS		IRT	1
	2016-05-13	MR	MR					HEC-BMS001	1
Modification		Date	Name	Checked		Source		Revision AM7813 Page	
								Previous page #758677/1 Next page #758677/1	

IRT UVA-2 PrepCure 4 230V 1 phase

THE INFORMATION CONTAINED HEREIN IS PROPRIETARY TO HEDSON TECHNOLOGIES AB
AND IS NOT TO BE REPRODUCED, COMMUNICATED TO A THIRD PERSON, OR USED
WITHOUT THE EXPRESS WRITTEN PERMISSION OF HEDSON TECHNOLOGIES AB.

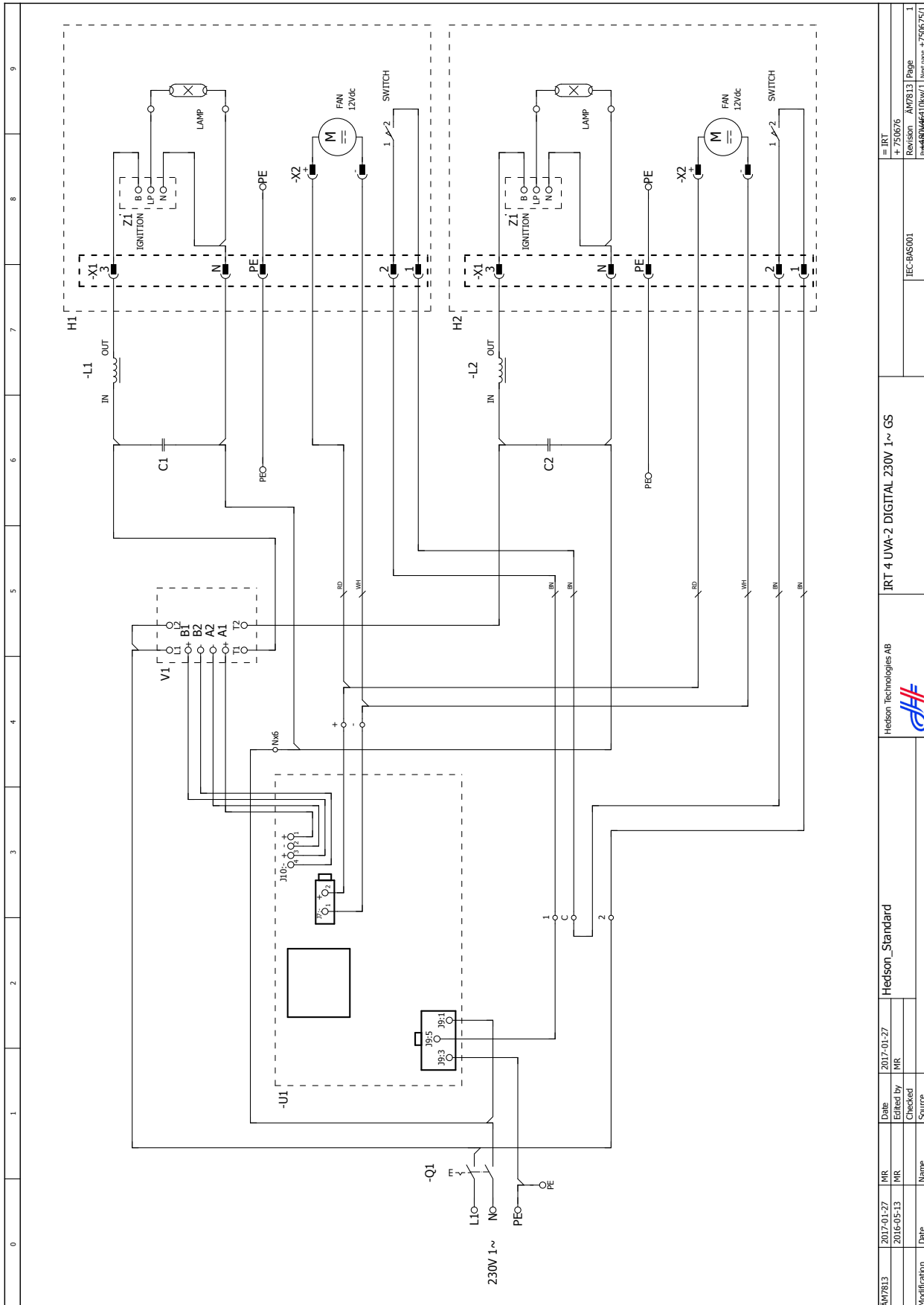

AN7813	2017-01-27	RR	2017-01-27	Hedson_Standard	IRT 4 UVA-2 DIGITAL 230V 1~ GS	TEC-BA5001	IRT + 750676
Modification	Date	Name	Date				Revision
	2016-05-13	RR					AN7813
							Page
							1
							Page
							1
							Page
							1

14. Dimensions

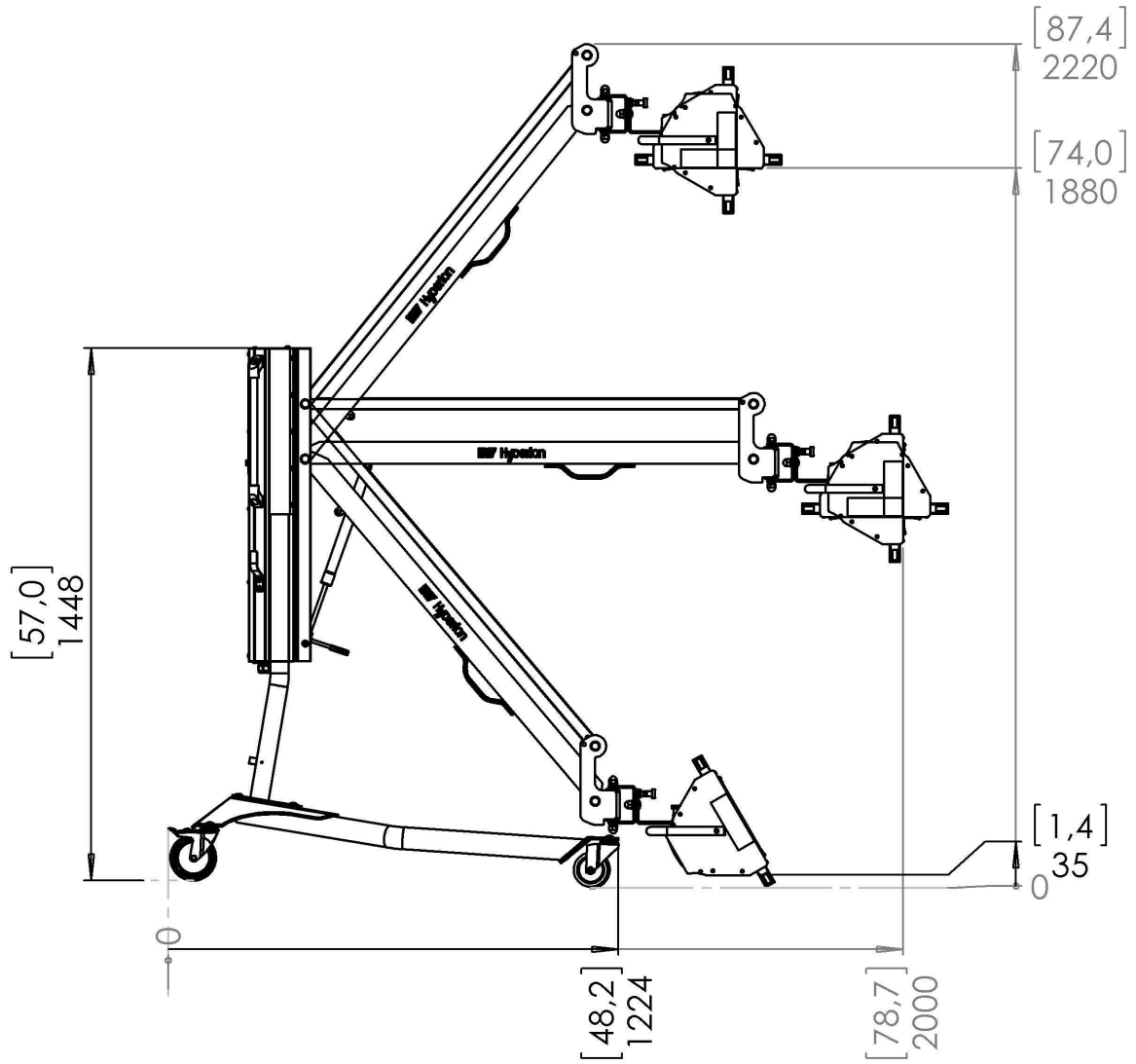

© Hedson Technologies N.A. Inc 2016
The manufacturer reserves the right to introduce technical modifications.



— PERFORMANCE ABOVE ALL —

Hedson Technologies AB

Hammarvägen 4
232 37 ARLÖV, Sweden
Tel. +46 40 53 42 00
info@hedson.com
www.hedson.com

Hedson Technologies N.A. Inc

Phone 1-866-IRT-HEAT (478-4328)
www.hedsonna.com
sales@hedsonna.com