

Operating manual and test record  
for  
service lift

Machine type	Article No.	Serial No.
K 1200-M	HM1100-01	
K 1200-M	HM1100-04	





---

## Table of contents

1	Operation and Safety Inspection .....	5
2	General information.....	6
2.1	Hazard warnings .....	6
2.2	Limitation of liability .....	6
2.3	Copyright.....	7
2.4	Terms of guarantee.....	7
2.5	Customer service .....	7
3	Master data sheet.....	8
4	Product description.....	9
4.1	Intended use .....	9
4.2	Product structure .....	10
4.3	Technical data.....	11
4.4	Product designation .....	11
5	EC Declaration of Conformity.....	12
6	General safety instructions.....	13
6.1	Operator's duty of care.....	13
6.2	Operator's duties.....	13
6.3	Basic safety measures .....	14
6.4	Requirements of operating personnel .....	15
7	Transport and preparation.....	16
7.1	Transport inspection.....	16
7.2	Disposal of the packaging materials.....	16
8	Installation and Assembly.....	17
8.1	Environmental conditions for assembly.....	17
8.2	Assembly Instructions .....	18
8.3	Operating instructions for handle and wheel (Special equipment HM1100-01) .	20
9	Operation .....	22
9.1	Description of Control Elements.....	22
9.2	Commissioning.....	23
9.3	Description of safety catch .....	23
9.4	Adjustment possibilities of the swivel arm (HM1100-01).....	24

---

9.5	Operating .....	25
9.5.1	Use of the lifting platform: .....	25
9.5.2	Lifting the platform: .....	26
9.5.3	Lowering the lift platform: .....	26
9.5.4	Exiting the service platform.....	26
9.6	Working on the lifted vehicle .....	27
9.7	End of work .....	27
10	Troubleshooting.....	28
10.1	Possible problems and their resolutions.....	28
11	Maintenance.....	29
11.1	Air bags characteristics and durability .....	30
11.2	Notice about filter regulator and air line.....	30
11.3	Notice about the sliding area of the scissors .....	30
11.4	Lubrication and test points .....	31
12	Safety Inspection.....	32
12.1	Regular safety check.....	33
13	Disassembly and Disposal .....	34
13.1	Disassembly.....	34
13.2	Disposal .....	34
14	Additional information.....	35

# 1 Operation and Safety Inspection

Carried out by the manufacturer to check the following details:

Following plates present:

- Nameplate
- Operating instructions (abbreviated)
- Lifting capacity
- Bar mains pressure
- Raise "up", - lower "down"
- Company logo
- CE marking

Operation and safety checked:

- Safety valve set to 3.5 bar operating pressure**

Inspected:

- Unladen function test
- Safety catch function
- The control valve automatically goes into the 0 position
- No damage to the surface of the air bags
- Secure fit of all supporting screws
- Safeguard of the scissor pins
- Condition of the pneumatic lines (proper position and do not leak)
- Support arms

Serial No.: See cover sheet

Date: \_\_\_\_\_

Name: \_\_\_\_\_

Herkules Hebetchnik GmbH  
Falderbaumstraße 34  
D - 34123 Kassel  
Tel.: +49 (0) 561/58907-0  
Fax: +49 (0) 561/58907-34

## 2 General information

The operating instructions (and test log book) contain important information concerning the installation, and ensure safe, proper, and economical operation as well as preservation of operational safety. Observance of these operating instructions will help you to avoid danger, reduce repair costs and downtime as well as to increase the life of your service lift.

As evidence of regular **safety checks** this test log book contains a form. This should be used to provide documented details of tests. (It is advisable to make a copy of the form before starting to fill it out.)

### Installation and testing

Safety-related work and safety inspections may only be performed by suitably trained personnel. In this documentation, personnel are designated as expert and qualified persons.

## 2.1 Hazard warnings

To identify hazardous areas and important information, the following symbols with the described definitions are used. Please pay special attention to text sections marked with these symbols.



Signifies danger for life and limb, meaning improper execution of the process referred to by the symbol may be fatal!



Signifies a notification of a key function or an important notice!

## 2.2 Limitation of liability

All details and indications in this operating manual were compiled taking into account the applicable standards and regulations, and the latest technology as well as our many years of insight and experience. The manufacturer accepts no liability for any damage caused by:

- Failure to adhere to the operating manual
- Improper use
- The intervention of non-qualified staff
- Arbitrary alterations
- Neglecting maintenance

## 2.3 Copyright

These operating instructions are to be treated as confidential and are solely intended for personnel working with the machinery. Transfer of the operating manual to third parties without the written consent of the manufacturer is prohibited.



**Text, drawings, images and other illustrations are copyrighted and intellectual property rights apply.**

## 2.4 Terms of guarantee

The terms of guarantee are included as a separate document in the sales brochures.

## 2.5 Customer service

For technical information, please contact our customer service centre as follows:

<b>Customer service:</b>	Herkules Hebetchnik GmbH Falderbaumstraße 34 D - 34123 Kassel Tel.: +49 (0)561 58907-0 Fax: +49 (0)561 58907-34 E-mail: info@herkules.de
--------------------------	---

### 3 Master data sheet

Name; Type: .....

Serial No.: See cover sheet

Manufacturer: **HERKULES Hebetchnik GmbH**  
**Falderbaumstr. 34**  
**D-34123 Kassel**

**Intended use:**

The lift with air bag and scissor system is a lifting machine for lifting vehicles with a permissible load capacity (see technical data) of a maximum load distribution of 3:2 in the driving direction or 2:3 against the driving direction.



**Any construction-related modifications as well as basic repairs are to be recorded on this master sheet!**

**Changes to the construction, testing by experts, re-commissioning**  
(Date, type of change, expert signature)

.....  
Name

.....  
Address of assessor

.....  
Location

.....  
Date

.....  
Signature of assessor



## 4 Product description

### 4.1 Intended use

The lift is exclusively intended for lifting vehicles (passenger cars) with a maximum nominal load (**see chapter on Technical data**).

Lifting individuals and other objects is prohibited.

Working under a lifted vehicle and during the lifting and lowering movement is not permitted.

Operation may only be performed by persons who have read and understood the operations manual and who are more than 18 years of age.

Lifting vehicles is only allowed at the lifting points specified by the respective vehicle manufacturers.

The scope of intended use also includes the reading of the current operating manual as well as compliance with all the indications included in the same – particularly safety instructions.

The scope also extends to ensuring that all inspection and maintenance operations are implemented within the prescribed time periods.

If the vehicle lift system is not used according to its intended use, safe operation of the system cannot be guaranteed.

In the event of any accident resulting in personal injury or damage to property resulting from improper use, the operator of the lifting system shall be responsible and not the manufacturer!

The product HM1100-04 described in these operating instructions can be used in explosion hazardous areas and are subject to the Directive 94/9/EC. Measures to protect against explosion hazards are required. See **Chapter "general safety information"** and **Chapter "Installation"** for further information.



**The marking of the equipment is Ex II 3G c IIA T4**

The lifting platform is part of the machinery group II, category 3; used in general industry in Area 2 for gases of explosion group IIA

c = constructional safety

T4 = up to 135 ° C surface temperature

Version as a category 2 is available upon request

## 4.2 Product structure

The vehicle lift HM consists of a pneumatically operated lifting base and swivel arms from which the vehicle to be lifted is loaded directly from the respective lifting point.

The air bag performs an axial stroke movement that is carried out laterally by the scissors. The scissors also restrict the lift height of the service lift. A safety catch prevents the service lift from sinking in the case of deflation.

The vehicle is completely lifted by means of the four adjustable swivel arms.

The operation of the service lift ensues with an operating unit that is connected to the lift via two pneumatic tubes (air bags / safety catch).

Technical data about the service lift is available in **the Technical data Chapter**.

You will find reference to professional assembly in the **Mounting Chapter**.

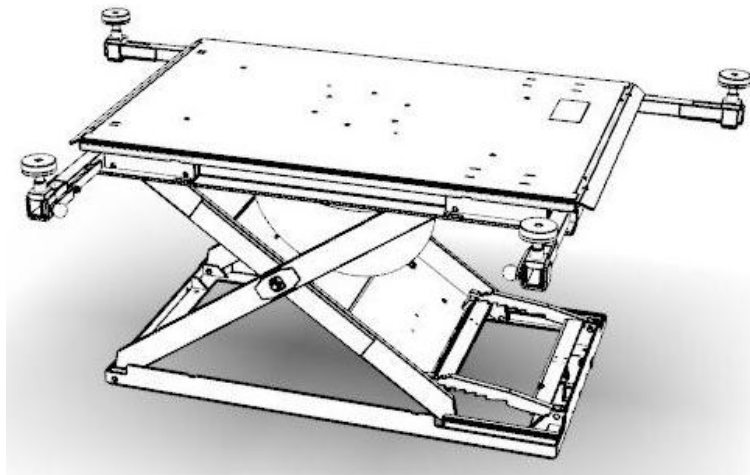

Diagram 1: Product HM1100-01

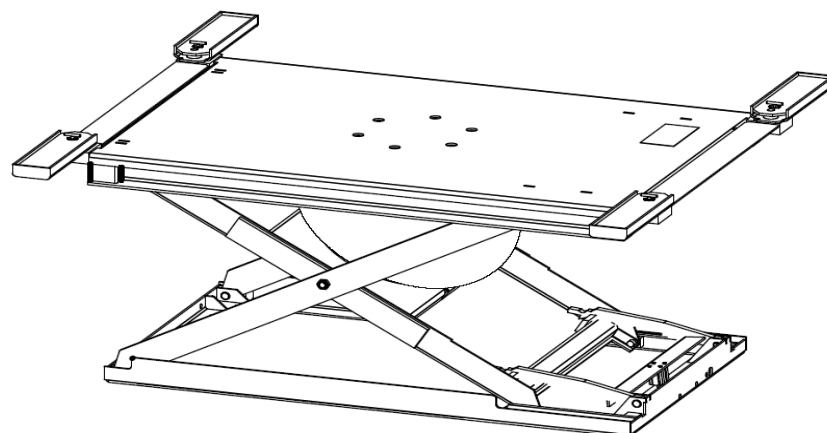

Diagram 2: Product HM1100-04

### 4.3 Technical data

<i>Technical changes reserved.</i>	HM1100-01	HM1100-04
Lifting capacity of the service lift	2800 kg	
Empty weight of the service lift	approx. 500 kg	
Maximum load distribution	3:2 in or against the driving direction	
Lifting time of the service lift	approx. 15 sec.	
Lowering time of the service lift	approx. 20 sec.	
Effective stroke of the service lift	825 mm	
Height of the service lift	930 mm	
Insertion height minimum/ overhead height	105+5 mm	no
Length of the base body	1705 mm	1797 mm
Width of the base body	1126 mm	1126 mm
Length of the support arms	2297 mm	2429 mm
Width of the support arms	1832 mm	1702 mm
Gear	pneumatic (2 air bags)	
Operating pressure for the safety valve	3.5 bar	
Pneumatic connection to supply system $P_{max}$	8 bar (provided by the customer)	
Noise pollution under	70 dB(A)	
Dimension sheet	K 1208-M-001-3	K 1208-M-004-3
Assembly plan		K 1208-M-017-3Bl.1
Base safety frame		K 1208-M-017-3Bl.2
Pneumatic circuit layout	K 1208-008-4 part 1	
Replacement Parts	K 1208-008-4 part 2	
Operating unit	K 1201-036-4 part 1	
Replacement parts operator control module	K 1201-036-4 part 2	
<b>Safety devices</b>		
Safety catch	yes	
Safety valve	yes	

### 4.4 Product designation

The details of the lifting platform are stated on the type shield on the machine frame as well as in the EC Declaration of conformity.

Details Nameplate

Article No.		Year of construction	
Machine type		Operating pressure	
Serial No.		Vers.	
Lifting capacity		Empty weight	

## 5 EC Declaration of Conformity

set out in Annex II A of the EC Machinery Directive  
(2006/42/EC)

The manufacturer	<b>Herkules Hebetchnik GmbH</b> <b>Falderbaumstraße 34</b> <b>D - 34123 Kassel</b>			
	<b>Herkules Hebetchnik GmbH</b>			
is responsible for the documentation and declares that the following machine described,	<b>the service lift</b>	<b>machine type</b> <b>K1200-M</b> <b>K1200-M</b>	<b>Art.- No.</b> <b>HM 1100-01</b> <b>HM 1100-04</b>	<b>Serial No.:</b> <b>See cover sheet</b> <b>See cover sheet</b>
the health and safety requirements fulfills the following EC standards :	<b>EC -Machinery Directive 2006/42/EC</b> <b>Directive 94/9/EG</b> <b>Ex II 3G c IIA T4</b>			
EC type examination	certificate No.			
K1200-M-01 K1200-M-04	44 205 10 377983-001			
inspecting authority	TÜV Nord Cert GmbH			

**Any construction-related modifications, which affect the technical data specified in the operating instructions and thus significantly alter the intended use of the machine, shall render this declaration of conformity null and void!**

Kassel, 27.07.2010

Location, Date



René Bartsch, executive direct

## 6 General safety instructions

### 6.1 Operator's duty of care

The lifting platform HM was designed and built taking a hazard assessment into account and following careful selection of the harmonised standards to be met, as well as additional technical specifications. It thus corresponds to the state of the art and guarantees the utmost level of safety.

However, this safety level can only be reached during practical operation, when all measures required have been implemented. The Due diligence is required on the part of the operator of the lifting platform, to plan these measures and ensure their implementation.

**The operator must, in particular, ensure that**

- The lifting platform is only used as intended (**see chapter on Product description**).
- The service lift only be used in a fully functional and fault-free state and will be checked regularly for operational functionality with special attention to safety equipment.
- The placement of the service lift is located and designed so that the operator is able to observe all movements of the load as well as have an overview of the area under the lift and its load. The operator is responsible for supplying adequate lighting.
- Access to the danger area (area under the lifting platform and under the load) by individuals is forbidden. Operations in the danger area are prohibited. Maintenance operations are excluded, (**see Chapter on Maintenance**).
- The operating instructions are to remain fully readable and available in the area in which the lifting platform is used.
- The lifting platform is only used by individuals having read and understood the operating instructions.
- Personnel are to be regularly instructed of all relevant information regarding work safety and environmental protection and familiar with the operating instructions and the safety notices therein.
- Only qualified individuals and experts may repair the lifting platform.
- None of the safety and warning notices linked to the lifting platform are to be removed and must remain readable.
- No interference with the service lift (for example, repairs) should take place without adhering adequately to protective measures (safeguard the base from sinking with a service support).

### 6.2 Operator's duties

The operating safety ordinances are intended for the operators of work equipment used in vulnerable areas.

The operator must take a risk assessment of the area where the work equipment (service lift) will be used. The dangers that arise during the use of the work equipment related to the substances and working environment should be detected and taken into account.

The operator shall take the measures necessary and choose operating equipment suitable for the conditions prevailing at the workplace and assure the safety and health of employees.

For the execution of risk assessment and decision on suitable equipment, the operator must apply country-specific guidelines and standards.

## 6.3 Basic safety measures



When operating the service lift, the statutory accident prevention regulations in accordance with BGV A1 (General requirements) apply. Regulations BGR 500 (operators of work equipment) can be used for information purposes.



Make sure that the front wheels are in the straight-ahead position. Before lifting, prevent the vehicle from rolling away. Pull the hand brake and shift the car into reverse or first gear. For vehicles with automatic transmission shift the car into the P position.



The operator is to monitor the vehicle during lowering and lifting.



Service lift parts such as air bags or air bags must be protected while working with high temperatures (welding, grinding, etc.) and from mechanical and chemical damage.

Compliance with the following points is particularly emphasised:

- The service lift is only to be used for lifting passenger cars.
- The total weight of the lifted car may not exceed the stipulated lifting capacity, whereby a maximum load distribution of 3:2 in the driving direction or 2:3 against the driving direction is permitted.
- While operating the service lift, instructions in the operator's manual are to be complied with.
- Only persons who are 18 years old or older and instructed in the use of the service lift are permitted to use it.
- During lifting and lowering movements, no person other than the operator may stand in the way of the area of movement for loading and service lift.
- The transport of passengers on the service lift or in the car being lifted is prohibited.
- Climbing on the service lift or in the car being lifted is prohibited.
- Following any modifications to the construction and repairs to load-bearing parts, the service lift must be inspected by an expert. Changes and repairs must be recorded on the master data sheet.
- Rubber pads must be placed on the largest contact surface. It is not allowed to stack them.
- In the event of modifications (i.e. repairs) appropriate safety measures must be met. (Safeguard the base from sinking with a service support.)
- Sufficient clearance between low lying vehicle parts and the service lift should be ensured before lifting begins.



**Not complying with the safety regulations can cause serious injuries as well as damage to the lifted vehicle.**

## 6.4 Requirements of operating personnel

The lifting platform must only be used by individuals who have been suitably trained, instructed and authorised. These persons must be familiar with the operating manual and proceed in accordance with the same. The respective authorisations of the operating personnel are to be clarified.

Moreover, for the following activities, specific qualifications are required:

Operation	Execution
Installation	Herkules service assemblyman / qualified person
Starting up	Herkules service assemblyman / qualified person
Briefing	Herkules service assemblyman / qualified person
Fault clearance	Herkules service assemblyman / qualified person
Servicing	Herkules service assemblyman / qualified person
Maintenance	Herkules service assemblyman / qualified person
Repairs	Herkules service assemblyman
Disassembly	Herkules service assemblyman / qualified person

Operating individuals in training should only operate the lifting platform when supervised by an experienced person. Evidence of completed and successful training should be confirmed in writing.

All control and safety installations must, generally speaking, only be operated by suitably trained persons.

All individuals engaging in activities involving the lifting platform must read the operating instructions and sign to confirm that they have understood them.

## 7 Transport and preparation

### 7.1 Transport inspection

Check the order upon receipt of delivery for damages caused during transport. If there is identifiable damage, proceed as follows:

- Leave the goods and packaging in an unchanged state. Do not attempt to use the product.
- Immediately contact Herkules customer service.

**Customer service:** Herkules Hebetchnik GmbH  
Falderbaumstraße 34  
D - 34123 Kassel  
Tel.: +49 (0)561 58907-0  
Fax: +49 (0)561 58907-34  
E-mail: info@herkules.de



**Do not send back damaged goods before receiving confirmation from the customer service centre!**

### 7.2 Disposal of the packaging materials

The packaging material must be disposed of in accordance with the current environmental - and disposal guidelines.



## 8 Installation and Assembly

The following important safety instructions must be observed during the assembly of the service lift. Adhering to safety instructions helps to avoid life-threatening injuries, personal damages, as well as damage to machinery.

- The installation work must only be performed by suitably-trained persons and with compliance of the safety instructions during the process.
- Before commencing the installation work, the lifting platform must be investigated for damage in transit.
- Always ensure that only authorised persons enter the working space and that no other persons are exposed to any risk from the installation work.
- All machine connections (tubes) are laid out so that there is no risk of stumbling.
- Also read the **Chapter "General Safety Instructions"**.

### 8.1 Environmental conditions for assembly

The service lift is only suitable for use in dry, closed, indoor rooms.

The ground where the car lift is to be assembled should be horizontal and flat (according to DIN 18202), and the load capacity of the floor must be able to support the total weight of the service lift.

The operator is solely responsible for the selection of the installation location.

The service lift must only be used within a temperature range of 5°C to 65°C. During the selection of the assembly location bear in mind the measurements of the service lift that are outlined in the **chapter on Technical data** as well as the **chapter on Additional information** (take note of the measurements with a lifted vehicle as well).

Adequate ceiling height must be present (at least the total height of the service lift plus the vehicle height). Care must be taken that the minimum distances specified are adhered to (according to country-specific regulations and workplace ordinances) with regard to distance between walls and equipment respectively. It should be noted that the service lift must not block any emergency escape routes. Adequate lighting must be present at the assembly site (according to country-specific regulations and workplace ordinances).

A compressed air supply R1/2" of 8 bar mains pressure must be available at the service lift assembly location.









**Care must be taken in selecting the assembly location so that the operator has an unobstructed view of the service lift and the car being lifted.**

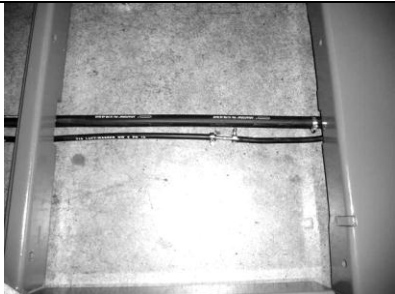

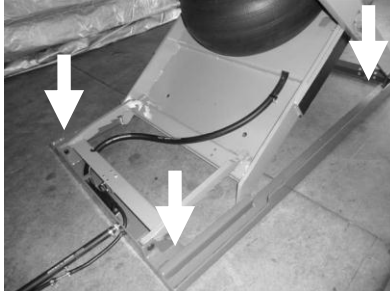

**Only use dehumidified, non lubricated compressed air! A filter regulator must only be installed in the mains connection (air filter and water separator)!**

## 8.2 Assembly Instructions

No		Description	Material requirements
1		<ul style="list-style-type: none"> <li>• Packaging units</li> <li>• Check the contents of the packaging</li> </ul>	1 platform base 1 accessories box  detailed assembly please see <b>chapter on Additional Information</b>
3		<ul style="list-style-type: none"> <li>• screw in hose nozzle</li> </ul>	1 hose nozzle 1/2"
4		<ul style="list-style-type: none"> <li>• Connect the hose lines onto the platform side</li> </ul>	1 rubber hose 16 mm 1 rubber hose 8 mm 1 hose connector 6 mm 2 hose clamp 10-16 1 hose clamp 16-25
5		<ul style="list-style-type: none"> <li>• Connect the hose lines onto the operator control module.</li> <li>• connect the compressed-air line (provided by the customer)</li> </ul>	1 operator control module 1 hose clamp 10-16 1 hose clamp 16-25
6		<ul style="list-style-type: none"> <li>• Move the service lift into the top end position. (Operating control unit: open the shut-off valve / hand lever to the "ON" position)</li> </ul>	

No		Description	Material requirements
7		<ul style="list-style-type: none"> <li>mount end bracket (on both sides)</li> </ul>	<p>2 end bracket                      4 hexagonal screws M12x40                      4 M12 nuts                      8 13 mm washers</p> <p><i>not applicable for HM1100-04</i></p>
8		<ul style="list-style-type: none"> <li>mount the swivel arms</li> </ul>	<p>4 swivel arms</p> <p><i>not applicable for HM1100-04</i></p>
9		<ul style="list-style-type: none"> <li>adjust and straighten the service lift</li> <li>secure the service lift (wells 16 mm)</li> </ul>	<p>4 hexagonal screws 12x100                      4 13 mm washers                      4 S16 dowels</p>
10		<ul style="list-style-type: none"> <li>install hose lines (in necessary shorten)</li> <li>mount operating control unit (mounting material: provided by the customer)</li> </ul>	

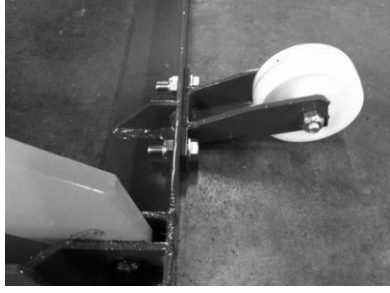
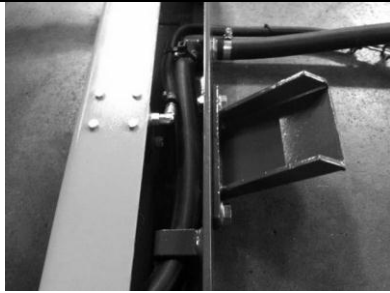
### 8.3 Operating instructions for handle and wheel (Special equipment HM1100-01)

No	Wheel drawbar	Description	Material requirements
1		<ul style="list-style-type: none"> <li>Move the service lift into the top end position. (Operating control unit: open the shut-off valve / hand lever to the "ON" position)</li> </ul>	
2		<ul style="list-style-type: none"> <li>mount wheel support (on both sides)</li> </ul>	2 wheel support 4 hexagonal screws M12x70 4 M12 nuts 8 13 mm washers
3		<ul style="list-style-type: none"> <li>mount hitch arm attachment bracket</li> </ul>	1 hitch arm attachment bracket 2 hexagonal screws M12x30 2 M12 nuts 4 13 mm washers
4			



The service lift may only be transported in its compacted state!

## 8.4 Grounding, electrostatic charge

If the lifting platform HM1100-04 is used in potentially explosive areas, all metal parts are grounded to prevent an electrostatic charge. The required material can be ordered if needed as an optional accessory from the Herkules Hebetchnik GmbH.



**All installed and removable parts of the lifting platform must be grounded for safety reasons. The grounding must be reliable and durable and able to withstand the expected loads. It is important to ensure a positively locking connection of the parts.**



**Metal parts of the machine are considered to be conductive and grounded to each other by means of electrical bonds to prevent any kind of electrically insulating layers. Paint-, powder coating, rust and grease are regarded as insulating layers.**



**Optional accessories grounding (article number: 805-173)**

### Hints for grounding:

- Pneumatic lines from the lifting platform must be grounded through hose clamps.
- The grounding line of the lower frame of the lifting platform must operate for its own grounding connection (Metal structure of the spray booth) is properly connected and grounded.
- All components of the lifting platform must be inspected during the installation and after any maintenance of adequate grounding.
- During operation of the lifting platform is to ensure that wear, tear, dirt, dust deposition or changes in the chemical and physical properties do not affect the explosion protection.
- Consult a qualified electrician if you do not understand the grounding instructions.

## 9 Operation

It is essential that the following safety instructions be followed while operating the service lift and the guidelines in the Chapter on **General safety instructions** be observed. Adhering to safety instructions helps to avoid life-threatening injuries, personal damages, as well as damage to machinery.

The lifting platform may only be used / deployed in accordance with its intended use. Please ensure that you are aware of what to do in the case of an accident or emergency before using the lifting platform.



**Individuals working with the lifting platform must wear safety shoes and be familiar with the operating instructions.**

### 9.1 Description of Control Elements

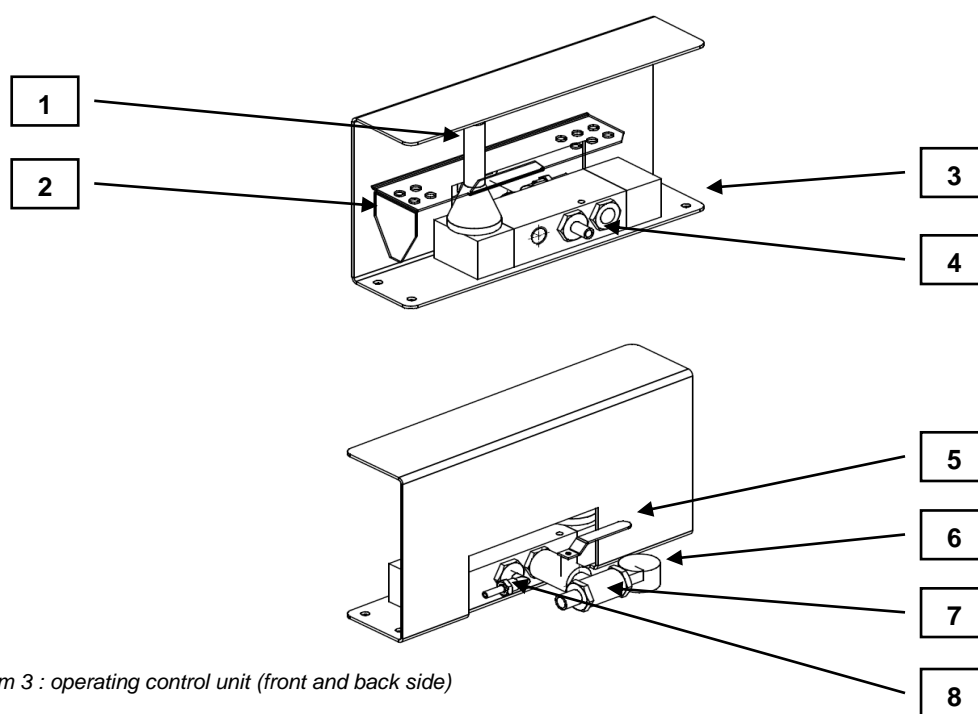

Diagram 3 : operating control unit (front and back side)

No.	Description	Additional information
1	hand lever	
2	foot pedal	optional accessory / special accessory
3	mounting points (4 parts)	mounting material not enclosed in the delivery contents
4	connector for compressed air supply	NW 7.2
5	main tap	
6	pressure gauge	air bags pressure display (max. 3.5 bar)
7	connector for hose line	16 mm (air bags)
8	connector for hose line	6 mm (safety catch)

The service lift is actuated with either the hand lever valve or the foot pedal. The control valve has three settings (with relevant markings): lift, 0-position, and lower. A stable framework protects the control valve. The pressure gauge shows the amount of pressure in the air bags.

## 9.2 Commissioning

Read the following functional checklist before using the service lift:

- Make sure that no persons or objects are present in the area of operation of the service lift.
- Secure the compressed air supply.
- Open the main tap on the operating control unit.
- Confirm that the operating control unit switch is in the lifting position - 'lift' until the service lift reaches the upper end limit.
- Confirm that the operating control unit switch is in the lowering position - 'lower' until the service lift reaches the lower end limit.
- Repeat lifting and lowering movements several times without load.
- The safety catch should lock into place at the end of each lift movement or in the intermediate position on both sides in the gear teeth.

Observe the operating instructions for the respective work places on the service lift. Only the operating personnel may stand in the vicinity of the service lift while in use.

Also read the **Chapter "General Safety Instructions"**.

## 9.3 Description of safety catch

- During lifting the safety catch is swivelled down. The catches of the safety catch slide on both sides of the detents of the inner scissoring. After the lifting motion the safety catch should be fully engaged on both sides to ensure safety.

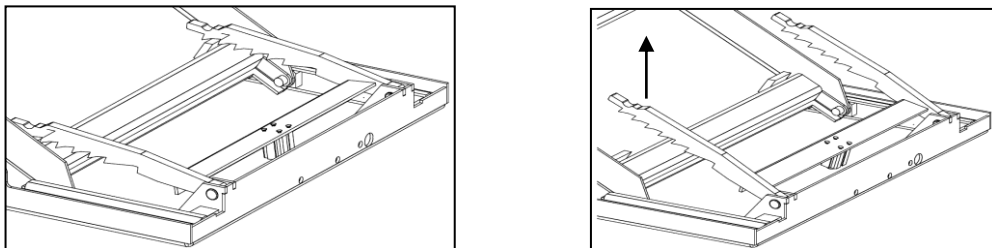

Diagram 4 / 5: safety catch engaged / safety catch lifted during lowering operation

- The safety catch is lifted up by means of the cylinder during lowering movement. At the end of the lowering movement or by interruption of the movement, the safety catch automatically drops and thereby grips into the detents of the service lift.



**Should the service lift not lower:**

**In this case briefly lift the service lift until the drop is free. Afterwards repeat the lowering movement.**

## 9.4 Adjustment possibilities of the swivel arm (HM1100-01)

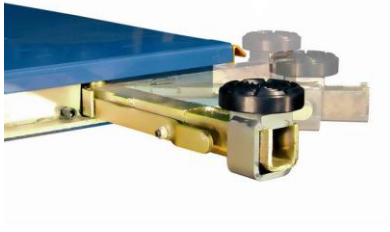
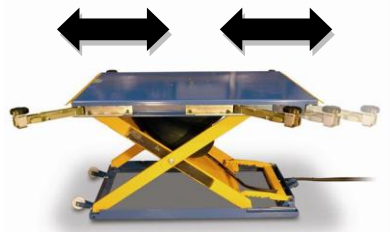
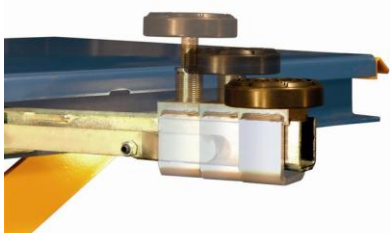
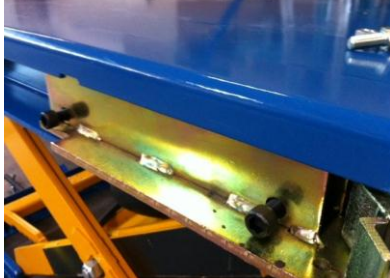
No		Description	Remark
1		<ul style="list-style-type: none"> <li>Rotation radius of the swivel arm</li> </ul>	<p>After completion of positioning ensure that the locking lever is properly engaged.</p>
2		<p>position the swivel arm (horizontal)</p>	<p>The horizontal movement is limited through the end face closing edge (they serve as end stop for the swivel arm)</p>
3		<ul style="list-style-type: none"> <li>position swivel arms</li> </ul>	<p>Infinite height adjustment through threads.</p>
4		<ul style="list-style-type: none"> <li>Adjust the tilt angle of the swivel arm</li> </ul>	<p>The tilt angles can be adjusted through both cylinder screws.</p>



Lifting of vehicles is only allowed at the lifting points specified by the respective vehicle manufacturers. Not complying with the safety regulations can cause serious injuries as well as damage to the lifted vehicle.



## 9.5 Operating

The safety guidelines in the **chapter "General safety instructions"** should be carefully read before operating and must be strictly adhered to during operation.

### 9.5.1 Use of the lifting platform:



*Diagram 6: HM1100-01 in initial state*

- Be sure that the lifting platform is completely retracted and that the swivel arm is folded in. (See **Diagram 6: HM1100-01 in initial state**)
- Remove back-up pads / rubber pads
- Load the service lift with a vehicle (in the direction of the arrow). Make sure that the vehicle is centred in both length- and width-wise on the platform.
- Secure the vehicle from rolling away by engaging the hand brake and shifting into gear.

## 9.5.2 Lifting the platform:

- Position the back-up pads / rubber pads of the swivel arm below the designated lifting points of the vehicle (see chapter "**Adjustment possibilities of the swivel arm**").



**Lifting vehicles is only allowed at the lifting points specified by the respective vehicle manufacturers. Not complying with the safety regulations can cause serious injuries as well as damage to the lifted vehicle.**

- Make certain that the lift platform can be safely raised.
- Switch the gear lever of the control valve to "lift " and hold it until the vehicle is lifted about ten centimetres above the swivel arm.
- Before lifting is carried out, ensure that the vehicle is securely on the lift platform.
- Proceed with lifting until the desired height is achieved. After the desired height is achieved, put the gear lever into the 0 position (neutral). The lift platform remains at this height. After releasing the gear lever, the lever automatically returns to the 0 position (neutral) and lifting ceases. Lifting automatically stops once the maximal lift height is achieved.



**Care must be taken during lifting, that the safety catch is securely engaged in the gear teeth on each side after each lifting movement (especially between movements smaller than the lift max.) This is noticeable through a clearly audible "clicking" sound.**

## 9.5.3 Lowering the lift platform:

- Areas subject to danger must be monitored before lowering and no persons or objects may be in the operation area of the service lift before lowering takes place.
- Switch the gear lever of the operating unit to "Lower".
- Lowering ends when the service lift has returned to its initial position. Stopping the lowering movement is possible at all times by switching the gear lever to the '0' position (neutral). Releasing the gear lever automatically causes the lever to switch back to the '0' position and thus interrupts the lowering movement.

## 9.5.4 Exiting the service platform

- Make sure that the service platform is completely retracted.
- Put the swivel arms in their initial position.
- Remove back-up pads / rubber pads.
- Carefully remove the vehicle from the service platform.

## 9.6 Working on the lifted vehicle

- Follow the legal regulations for the prevention of industrial accidents.
- Make sure that no one is in the space under the lifted vehicle.
- It is not allowed to put spare parts or tools on the lifted vehicle or lifting platform.
- Pay attention to the shift of the center of gravity when installing or dismantling heavy parts to or from the vehicle.
- Respect the weight shifting when install or dismantle heavy parts. Thereby the vehicle can tilt over the lifting platform.

## 9.7 End of work

After completing work with the service lift the following points should be adhered to:

- The service platform must be in the lower end limit.
- Close the main tap of the operating control unit.
- Guard the main tap from unauthorized use with a padlock (not included in delivery).

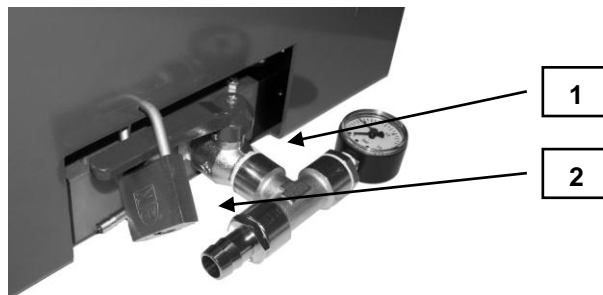

Diagram 7: Operating unit is safeguarded from unauthorized use

No.	Description
1	Main tap locked
2	Padlock (not included in delivery)

### Requirements of padlocks:

- padlock width: 38-43 mm
- closed shackle height: 28-35 mm
- shackle diameter: max. 6 mm

## 10 Troubleshooting

To avoid machine damage or life-threatening injuries while resolving faults with the lifting platform, the following points must be observed at all times:

- Only attempt to repair a malfunction if you are suitably qualified to perform such work.
- Protect the service lift from unintentional restart by disabling the compressed air supply.
- Secure the upper frame in the lifted position with a stand or a proper support.
- Also read the **chapter "General Safety Instructions"**.

### 10.1 Possible problems and their resolutions

Malfunction	Source of fault	Rectification of errors
Malfunction while lifting	Pressure gauge of the maintenance unit without bar mains pressure.	Make sure there is a mains pressure of $P_{max} = 8$ bar. Open the shut-off valve.
	Hose lines squashed, bent, or damaged.	Check the hose lines and if necessary replace them with new ones.
	Gauge pressure 1 bar above allowable pressure of the safety valve	Check the safety valve for contamination and replace if necessary.
Malfunction while lowering	Lift platform is resting on top of an obstacle	Raise the lift platform, remove the obstacle, and then continue lowering.
	Safety catch engaged	For bar mains pressure $P_{max} = 8$ bar make sure the gear lever is switched to "Lift" until the safety catch is free. Afterwards repeat the lowering movement.



If, despite the above measures, the lifting platform cannot be lifted or lowered, the customer service department must be notified.

**Customer service:**

Herkules Hebetchnik GmbH  
 Falderbaumstraße 34  
 D - 34123 Kassel  
 Tel.: +49 (0)561 58907-0  
 Fax: +49 (0)561 58907-34  
 E-mail: info@herkules.de



When replacing defective parts, always only use original spare parts from the manufacturer.

## 11 Maintenance

Maintenance work should be carried out at the specified maintenance intervals and only by qualified persons. Neither water nor flammable liquids may be used during the cleaning process.

To ensure durability and continuous operation of the service lift, the following points should be observed:



- Only spare parts from the original manufacturer and suitable tools may be used.
- Regular maintenance intervals must be observed.
- For all maintenance work not outlined or explained in this instruction manual, please contact your supplier or customer service of the manufacturer.

Only perform maintenance when the lift achieves a max. (unloaded), the lift platform is braced with service supports, and the compressed air supply is disabled!

Maintenance intervals	Points to follow	Comments
Monthly	<p>All moveable parts such as pivot bolts, sliding pads, and sliding surfaces should be check for wear and tear, cleaned, and lubricated.</p> <p>Check air bags and air tubes for any damages. Visually inspect and check for leaks. Examine the surface of the air bags for impurities, then clean, and maintain.</p> <p>Inspect valves for functionality and check for leaks.</p> <p>Check that the dowels are properly fixed. If necessary re-install or renew the support.</p> <p>Inspect the maintenance unit (filter regulator, provided by the customer), and consult the product manufacturer's instructions.</p>	<p>Only use lubricants that contain no adhesive-repelling substances in the area to be lubricated.</p> <p>Only suitable care and cleaning agents are to be used on rubber surfaces.</p>
Yearly	Regular safety check (In accordance with §10 ( 2 ) German Plant Health and Safety regulations)	For test protocol see <b>Chapter Regular safety check.</b>
Replace the safety valve	After every 2 years of operation.	
Every 6 years of operation	Replace the complete air hoses.	

## 11.1 Air bags characteristics and durability

The air bags are a flexible element developed and designed specifically for use in lift platforms. The rubber covering reduces the aging process and should be especially carefully checked. Experience shows that well kept air bags have a life expectancy of over 20 years.

Tips for a long operating life:

- Use dry as well as non lubricated compressed air.
- Protect from UV radiation (i.e. through welding or the use of a UV dryer).
- Avoid the use of chemical agents.
- Protect the unit from damage (grooving, etc.).
- Adhere to maintenance and care instructions (see **Chapter Maintenance**).

Damaged air bags must be replaced. Only original parts from the manufacturer are permitted to be used.

## 11.2 Notice about filter regulator and air line

The filter regulator is not included in the scope of delivery of the lift platform. A filter regulator must be installed in the mains connection (provided by the customer). Only dehumidified, non lubricated compressed air should be used. Follow maintenance and cleaning of the filter regulator, consult the information and instructions of the filter regulator manufacturer.

## 11.3 Notice about the sliding area of the scissors

Due to the design principles of the sliding surfaces of the scissors, great force is exerted. This force can lead to scoring on the sliding surfaces. However, the function of the service lift will not be compromised. The maintenance intervals and instructions outlined in the **Chapter Maintenance** are to be observed.

## 11.4 Lubrication and test points

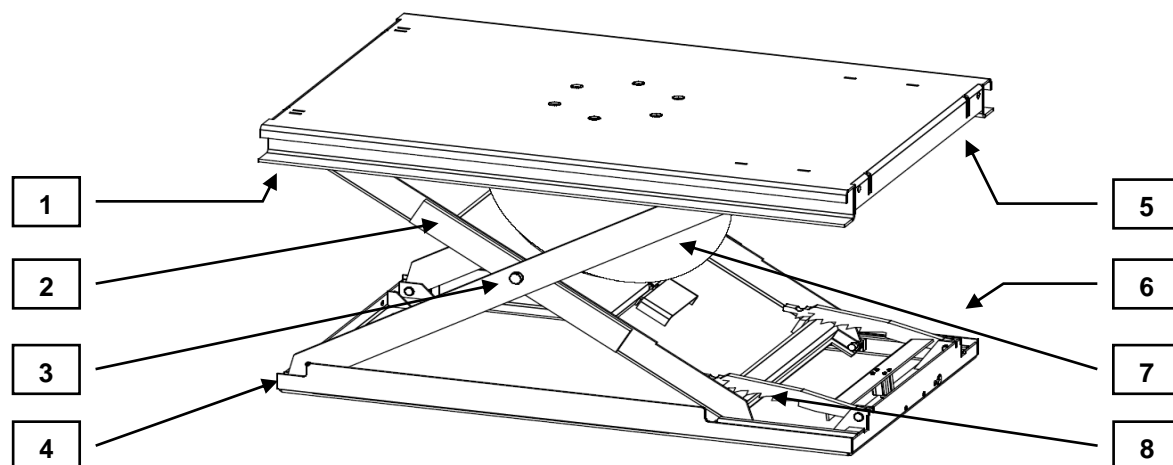

Diagram 8: Lubrication and test points

No.	Description	Lubrication and test points
1	bearing pin overhead (right and left)	<ul style="list-style-type: none"> <li>- Check the safety washers from both of the bearing pins for proper fit.</li> <li>- lubricate bearing pin</li> </ul>
2	sliding surfaces of the scissors (right and left)	<ul style="list-style-type: none"> <li>- Check the sliding surfaces of the scissors for wear.</li> <li>- lubricate sliding surfaces</li> </ul>
3	scissor pins (right and left)	<ul style="list-style-type: none"> <li>- Check that the scissor pins are properly fixed.</li> <li>- Check the safety nuts.</li> </ul>
4	bearing pins below (right and left)	<ul style="list-style-type: none"> <li>- Check the safety washers from both of the bearing pins for proper fit.</li> <li>- lubricate bearing pin</li> </ul>
5	sliding pads and guide rails above (right and left)	<ul style="list-style-type: none"> <li>- Check sliding pads for damage and wear.</li> <li>- Lubricate sliding pads and guide rails.</li> </ul>
6	bearing pin safety catch (right and left)	<ul style="list-style-type: none"> <li>- Check the safety washers from both of the bearing pins for proper fit.</li> <li>- lubricate bearing pin</li> </ul>
7	air bags	<ul style="list-style-type: none"> <li>- Check air bags for damage.</li> <li>- Check the screws on the air bags reinforcement both above and below for proper fit.</li> <li>- Treat the surface of the air bags with the appropriate rubber care product.</li> </ul>
8	sliding pads and guide rails below (right and left)	<ul style="list-style-type: none"> <li>- Check sliding pads for damage and wear.</li> <li>- Lubricate sliding pads and guide rails.</li> </ul>

## 12 Safety Inspection

Safety inspection is required to guarantee the operational safety of the service lift.

### It should be performed:

Before starting up the lifting platform for the first time by the manufacturer.

The use of which can be found under the section "operation and safety inspection" (**Chapter operation and safety inspection**).

After the first commissioning, check at regular intervals in accordance to §10 (2) BetrSichV (German Plant Health and Safety Regulations)!

The use of which can be found under the section "regular safety check" (**Chapter regular safety check**).

Document the condition of the service lift in a separate copy and attach it to the operating instructions and inspection log.



**Regular safety checks must be performed by a suitably-trained person. It is advisable to also implement maintenance at the same time.**



## 12.1 Regular safety check

(In accordance with §10 ( 2 ) German Health and Safety regulations !)

<b>Device type</b>	
<b>Serial number</b>	

Inspection step	OK	Not OK	re-examination	Remark
Nameplate				
Sign with lifting capacity				
Sign with bar mains pressure				
Operating instructions (abbreviated)				
Designation lift - lower				
Secure fit of all supporting screws				
Safeguard of the scissor pins				
condition of the pneumatic lines				
safety valve set to 3.5 bar operating pressure				
Pressure gauge bar mains pressure $P_{max} = 8$ bar				
Control lever returns automatically to the '0' position when released				
Safety catch function				
Swivel arm function				
Condition of the end bracket (end stop swivel arms) (only HM1100-01)				
Condition of the air bags				
Condition of the supporting structure				
Functionality of the service lift with vehicle				

Inspection result	
	Start-up not permitted, verification required
	Start-up possible, faults to be rectified by: .....
	No fault, start-up possible immediately

Safety inspection performed on: .....

Name and address of qualified personnel .....

.....  
Signature of competent person

.....  
Signature of operator

**With the required rectification of faults**

.....  
Signature of competent person

.....  
Signature of operator

## 13 Disassembly and Disposal

### 13.1 Disassembly

To correctly disassemble the system, perform the steps in the assembly instructions found in **Chapter Assembly instructions** in the reverse order.

The safety regulations in **Chapter General Safety Instructions** must be observed when disassembling the system.

### 13.2 Disposal

The service lift must be disposed of in accordance with the current environmental and disposal guidelines.

## 14 Additional information

### Spare parts platform-main body K1208

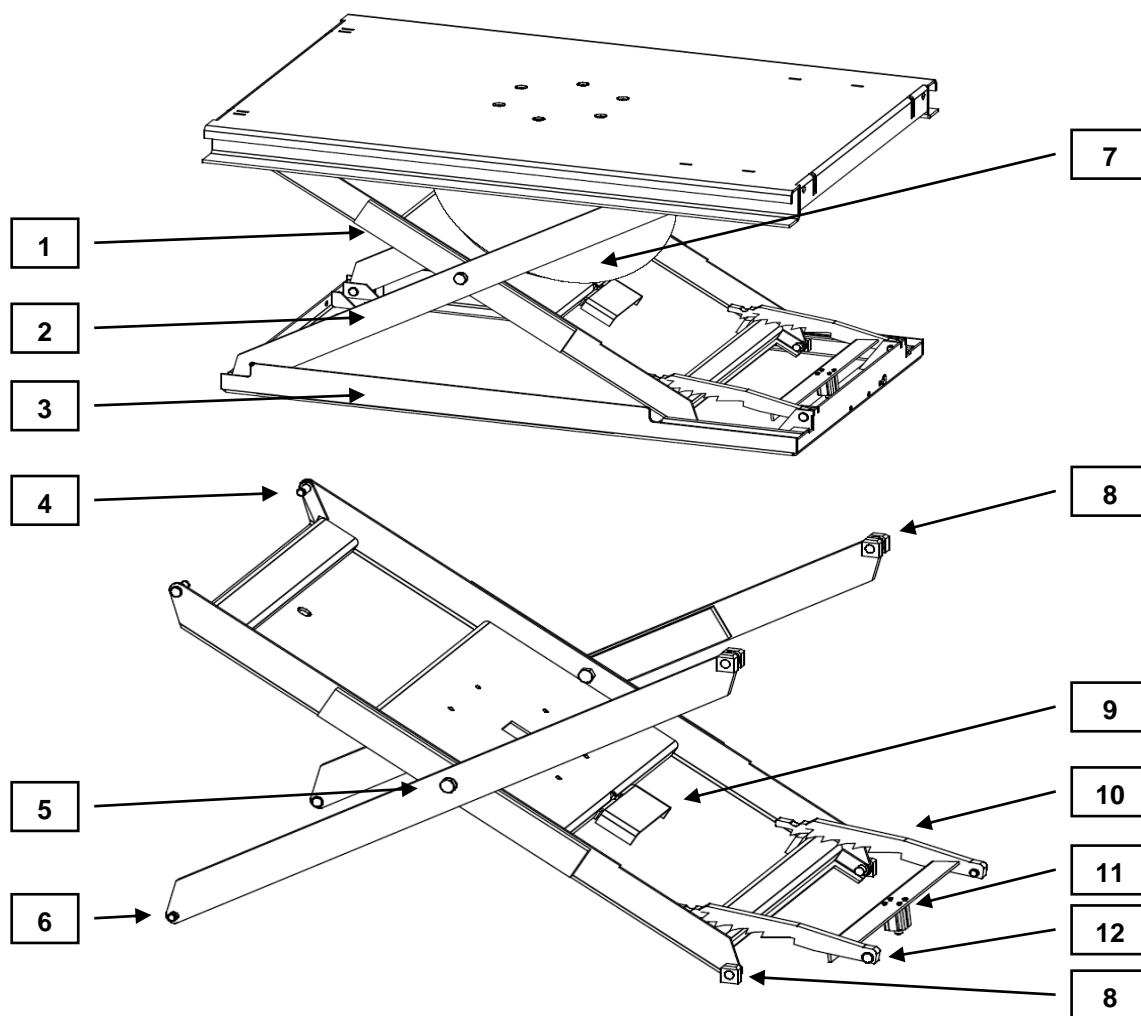

No.	Description	Item number
1	Internal scissor K1208	15357
2	Set external scissor K1208	15359 und 15361
3	Lower frame K1208	15354
4	Thrust bearing bolt (at the top) K1200	690-147
5	Middle bolt K1208	500-661-1
6	Thrust bearing bolt (below) K1200	690-139
7	Double air bag K1208	15733
8	Sliding piece	695-000
9	Safety valve (set up on 3.5 bar)	700-171
10	Anti-drop safety device K1200 / K1208-DUO	15362
11	Pneumatic cylinder drop safety	710-124
12	Anti-drop safety bolt	690-140
/	Hose package	3000-0003

**Scope of delivery of HM1100-01**

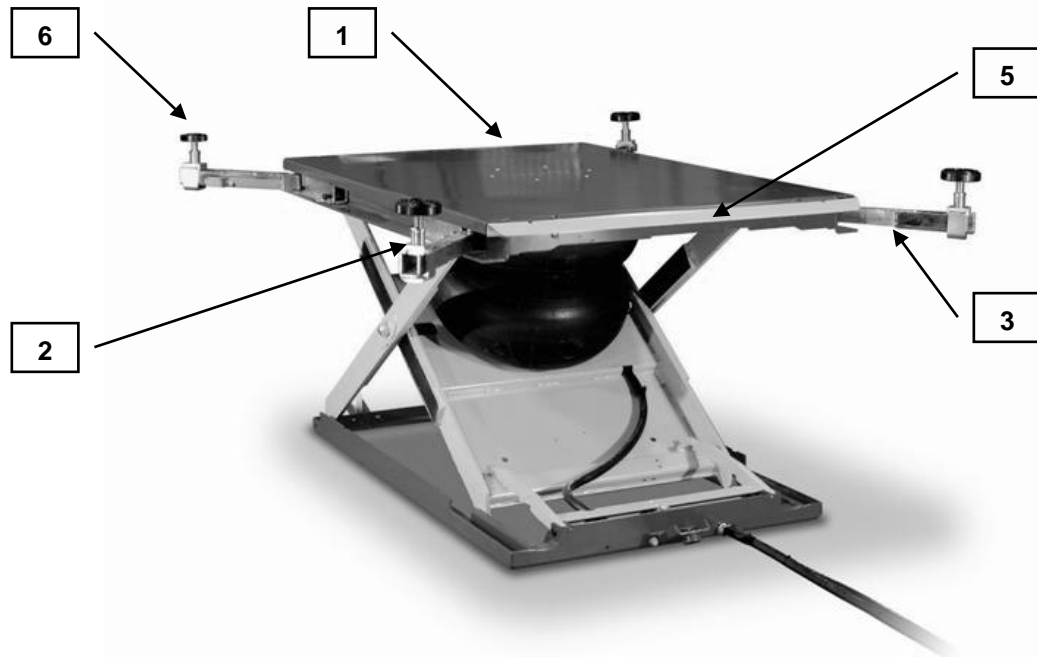

Diagram 9: HM1100-01

No.	Description	Article number	Number
1	lifting base	K1208	1
2	swivel arm (left)	15790	2
3	swivel arm (right)	15789	2
4	hand valve	300-249	1
5	end bracket / deflector	15606	2
6	swivel arms with rubber pad	15848	4
7	hexagonal screw DIN 933 M12x40	500-177	4
8	hexagonal safety nut DIN 985 M12	600-114	4
9	13 mm washers	650-113	8
10	13 mm washers	660-113	4
11	hexagonal wooden screw DIN 571 12x100	505-125	4
12	dowel S 16	810-155	4
13	hose nozzle 1/2" a x 16 mm	730-048	1
14	hose clamp 10-16x9	720-361	3
15	hose clamp 16-25x9	720-121	2
16	cable ties	810-109	10
17	rubber hose 6 mm	720-106	5 m
18	rubber hose 16 mm	720-113	5 m
19	brass hose connector 6 mm	730-318	1
20	Operating instructions HM	760-065	1

Scope of delivery of HM1100-04

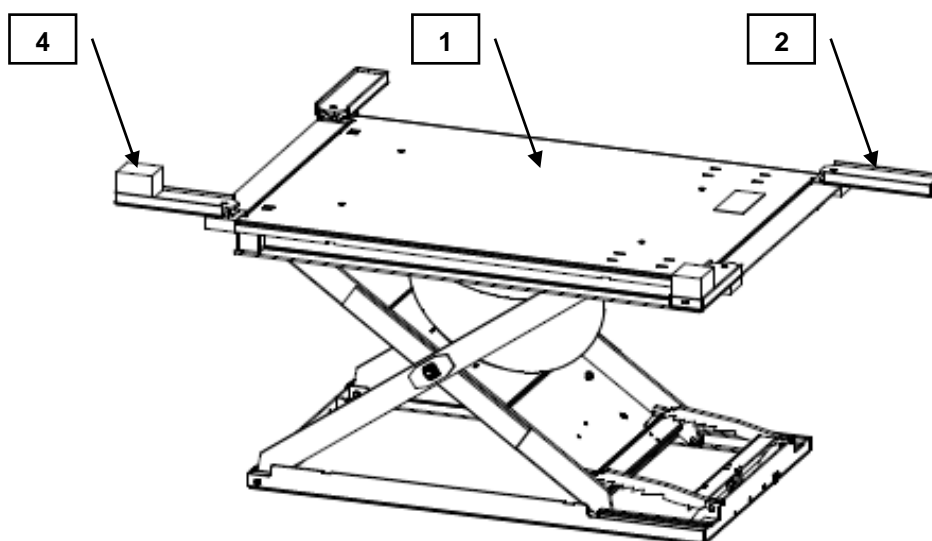

Diagram 10: HM1100-04

No.	Description	Article number	Number
1	base platform HM1100-04	GHM1100-04	1
2	support arm	15522	4
3	hand valve	300-249	1
4	rubber pad L 120 x B 100 x H 80 mm	800-105	4
5	13 mm washers	660-113	4
6	hexagonal wooden screw DIN 571 12x100	505-125	4
7	dowel S 16	810-155	4
8	hose nozzle 1/2" a x 16 mm	730-048	1
9	hose clamp 10-16x9	720-361	3
10	hose clamp 16-25x9	720-121	2
11	cable ties	810-109	10
12	rubber hose 6 mm	720-106	5 m
13	rubber hose 16 mm	720-113	5 m
14	brass hose connector 6 mm	730-318	1
15	Operating instructions HM	760-065	1

Pneumatic plan

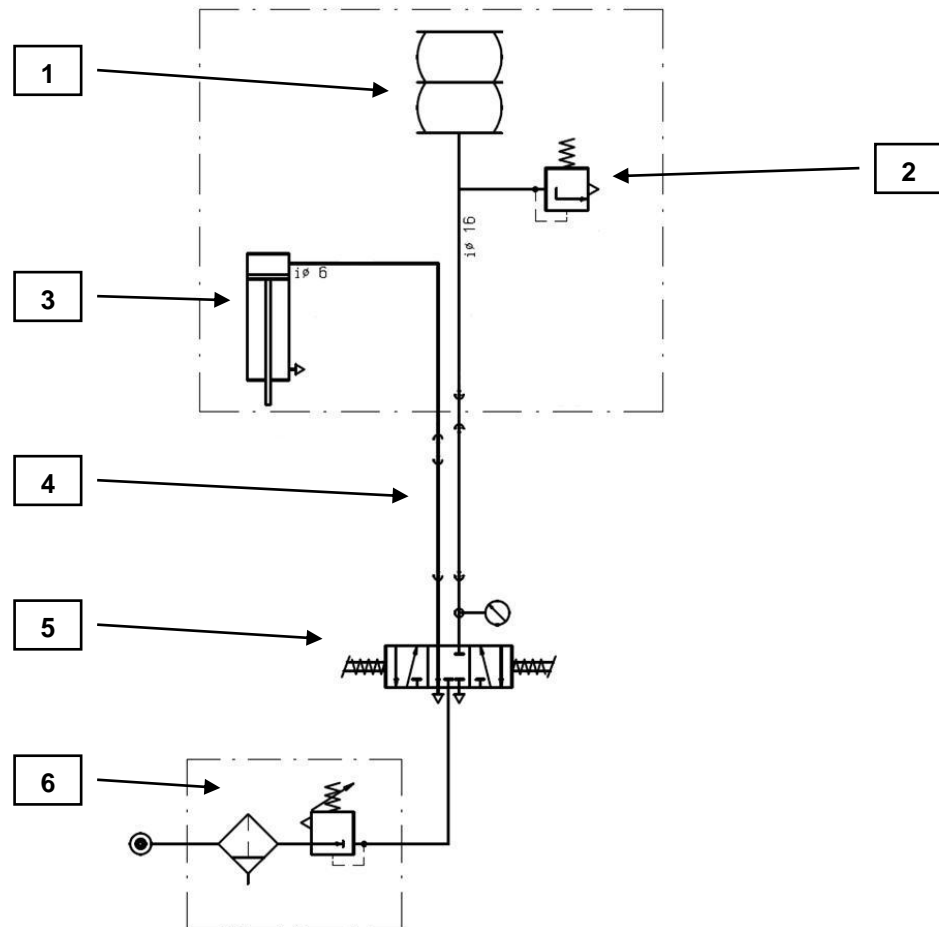

Diagram 11: Pneumatic plan K1208

No.	Description	Article number	Number
1	air bags double lever		1
2	safety valve (set to 3.5 bar)	700-171	1
3	pneumatic cylinder safety catch	710-124	1
4	hose packet (incl. connection materials)	3000-0003	
5	manual operating control unit (optional foot pedal)	300-249	1
6	maintenance unit (from the customer)	/	

Dimension sheet HM1100-01

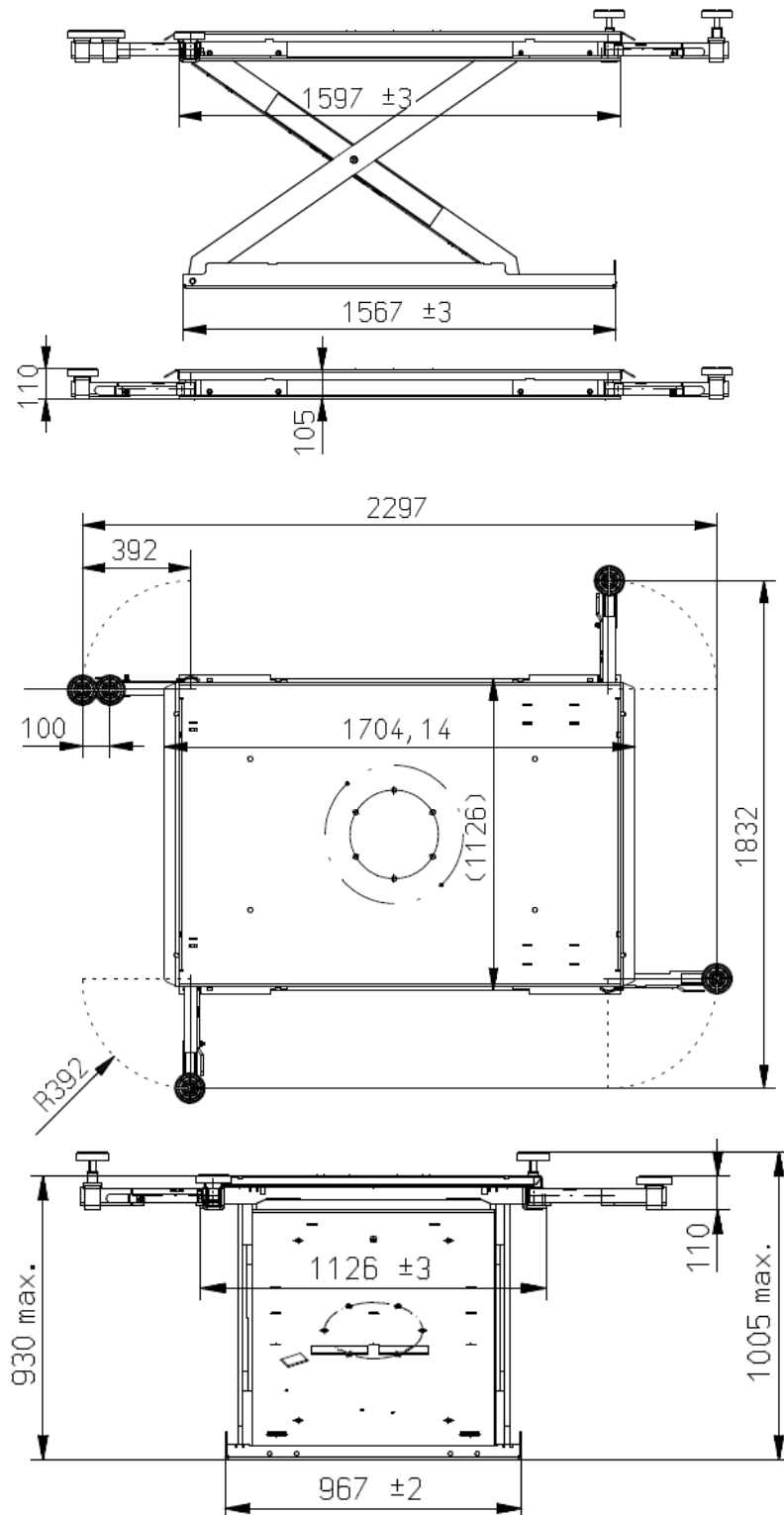

Diagram 12: Dimension sheet HM1100-01

Dimension sheet HM1100-04

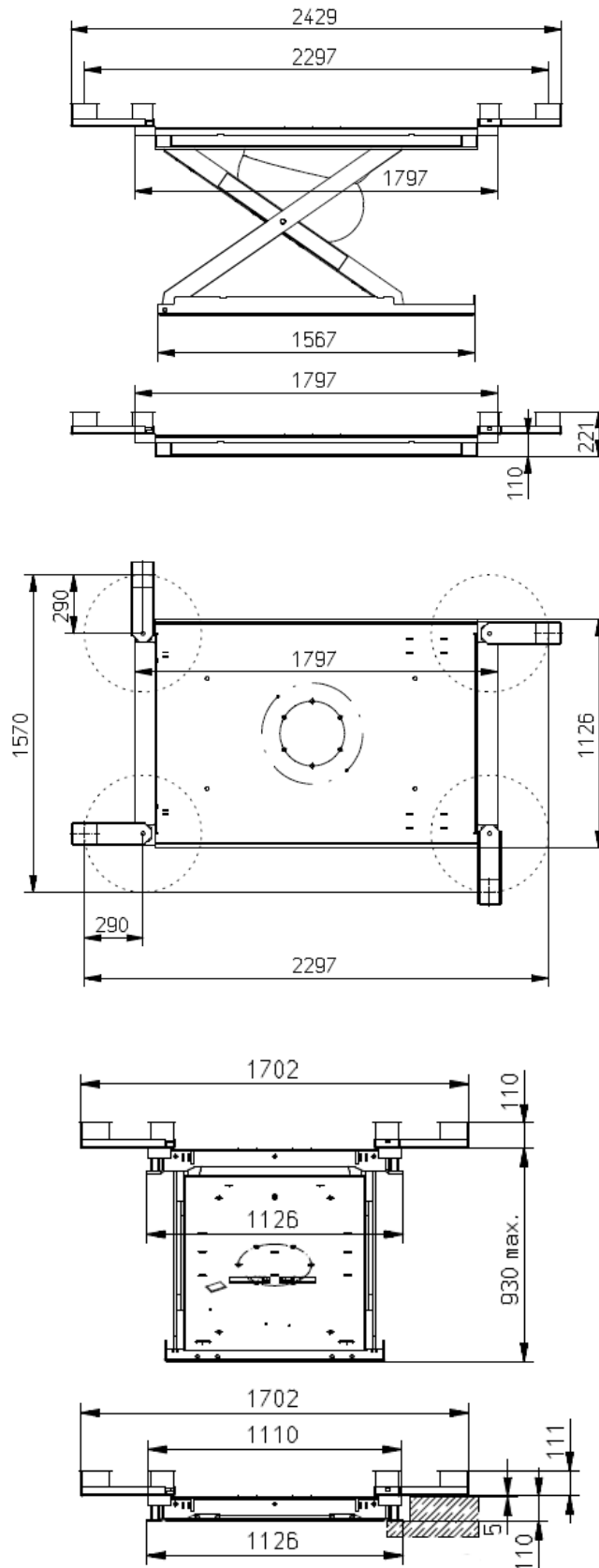

Diagram 13: Dimension sheet HM1100-04



Foundation plan HM1100-04

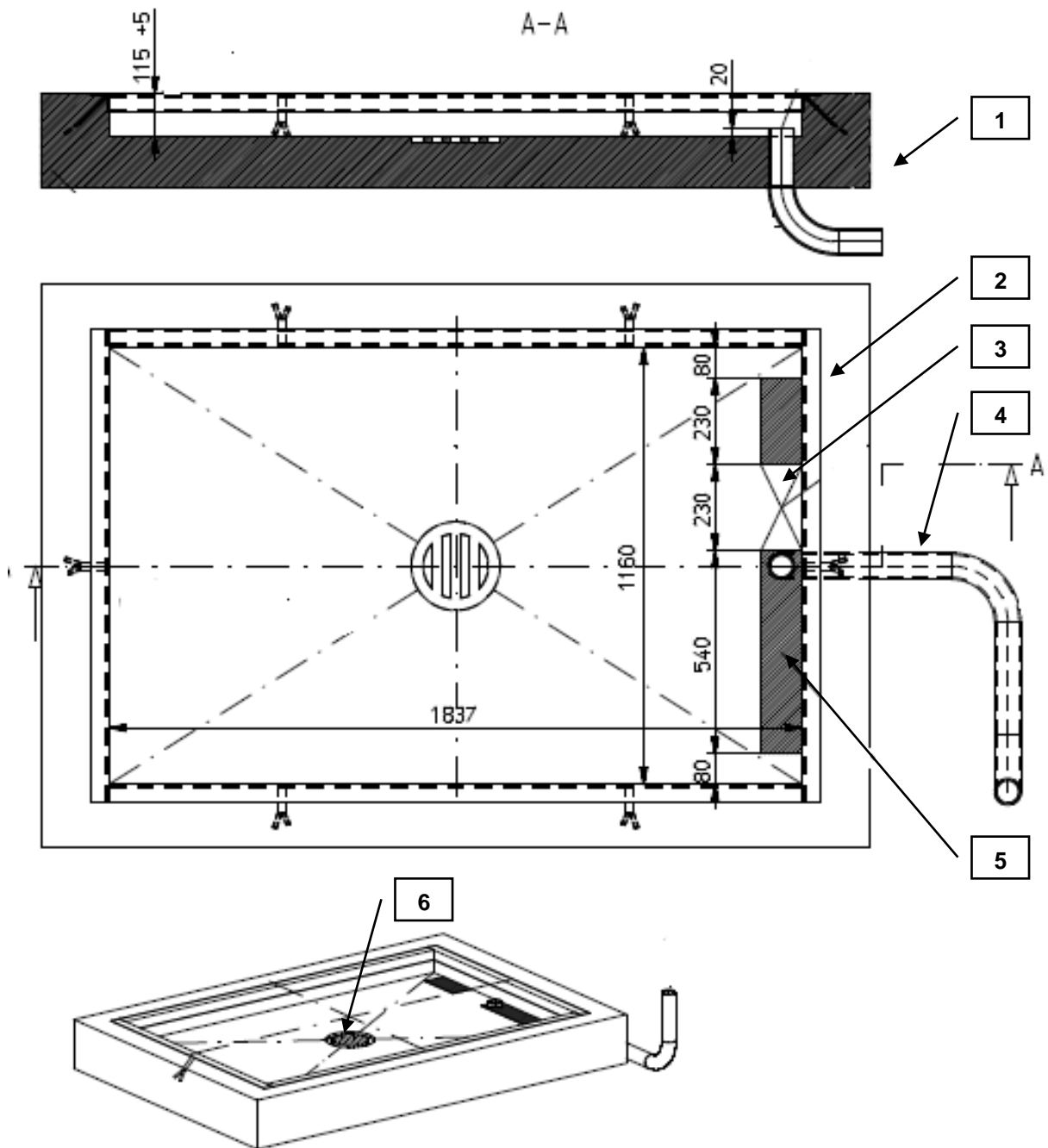

Diagram 14: Assembly plan / pit design for concrete mounting of HM1100-04

No.	Description
1	Concrete min. B 15 / min. strength 16 cm. Structural engineering calculations must be carried out on site.
2	Fundamental safety frame (not enclosed in the delivery contents).
3	Avoid placing the duct in this area.
4	The inner diameter of the tube should be a minimum of 70 mm.
5	The optimum area for ducts.
6	Recommendation: The gradient of the water outlet should be a minimum of 1%.

Fundamental safety frame K1208

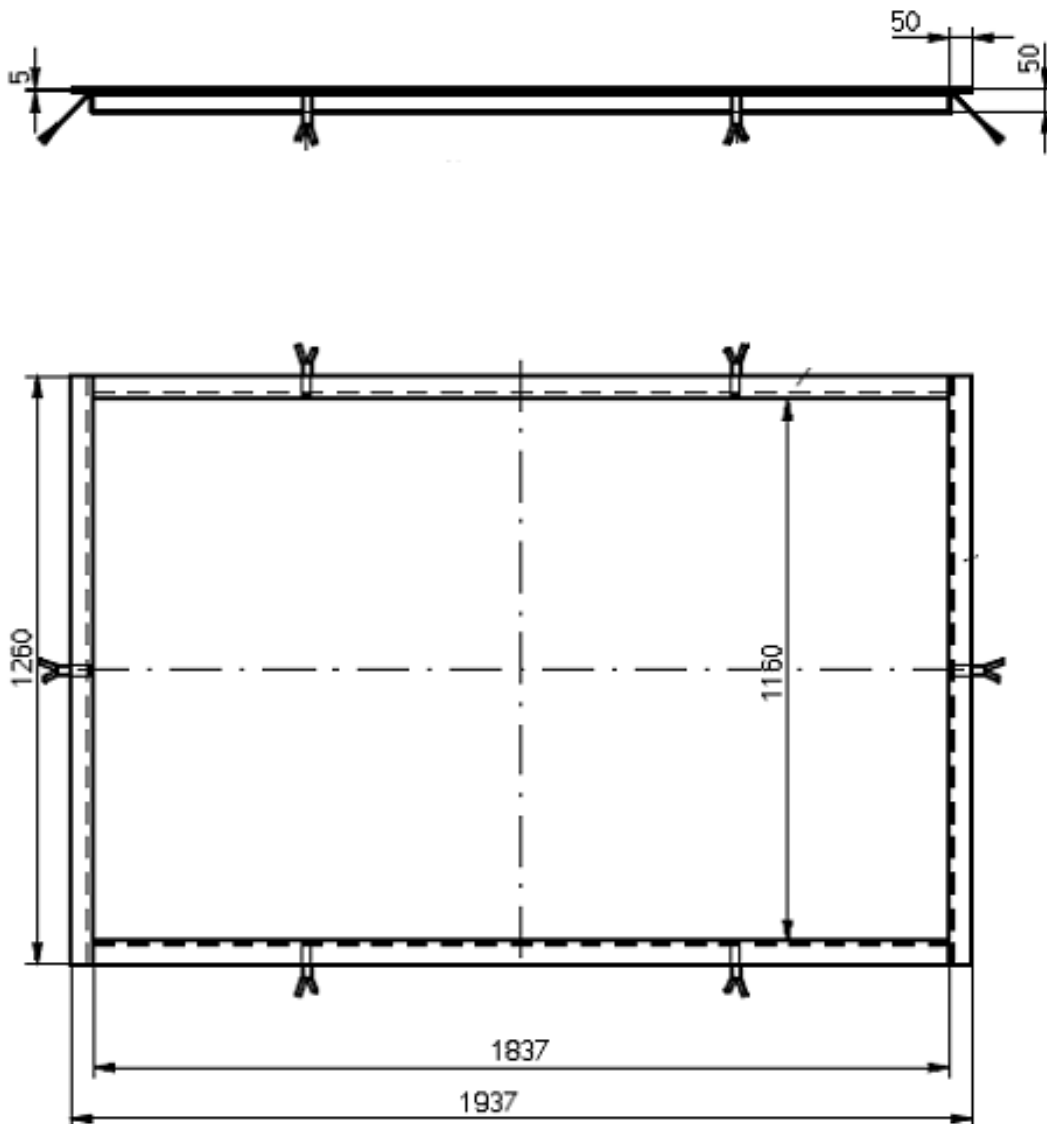

Diagram 15: Fundamental safety frame K1208

Article	Article number
fundamental safety frame primed for HM1100-04	300-317
fundamental safety frame zinc plated for HM 1100-04	300-318

**Notes:**