

OPERATION MANUAL

## IRT PowerCure

Infrared-drying arch for vehicles



## 1. Introduction to PowerCure

(Original language)

Manufacturer:

HEDSON TECHNOLOGIES AB

Box 1530, SE-462 28 VÄNERSBORG, Sweden

Tel. +46 521 281230 www.hedson.com

This product conforms with the following standards or other normative documents:

SS-EN 60204-1, EN 12100-1, EN12100-2

EN 61000-6-3, EN61000-6-2,

EN 1539, EN 13355,

SS-EN ISO 9001

SS-EN ISO 13857

under the terms of the following directives

Machinery Directive 2006/42/EC

Directive 2014/30/EU on Electromagnetic Compatibility

The product is intended for the installation in spray or combined spray and dry booths for passenger cars or similar motor vehicles. These booths must be conform to the European product standard EN 12215 (spray booths) and EN 13355 (combined spray and drying booths).

The control system of the IRT PowerCure comprises the following functions:

- Inhibition of spraying during the drying process
- Securing ventilation of the booth during the drying process
- Ventilation of the booth before the drying process
- Surveillance of the parking position and doors

The integrated control system is not intended to cover all safety orientated controls of the combined spray and drying booths. In particular, the control system cannot replace the ventilation monitoring in the spraying operation.

The device may be operated only with a fully functional original control system. This is the only way to ensure that the dryer cannot be switched on together with the operation of a spray gun.

The system should not be used for transportation or lifting purposes.

## 2. Contents

1.Introduction to PowerCure .....	2
2.Contents .....	2
3.Product description .....	3
4.Safety instructions .....	3
5.Control of the arch .....	4
6.Start-up / Operation .....	6
7.Care and maintenance .....	6
8.Installation and transport .....	8
9.Specifications .....	9
10. Spare parts list.....	9
11.Electrical schedules .....	10
12.Certificate of conformity .....	11
1.ANNEX I, Acceptance test .....	12

### 3. Product description

The IRT PowerCure generates infrared radiation, which heats the coating directly on a vehicle. The arch is motorized and automatically moves along the wall rails in the booth. By means of movable side panels, all exterior surfaces on a vehicle can be cured.

The curing process can be adjusted individually to the vehicle's dimensions and the properties of the used paint. The settings can be saved and recalled via the easy-to-use control system again.

The possibility for programmed radiation exposure of only the necessary surfaces of the vehicle leads to time and energy savings. Thereby, it helps you to run your workshop cost-effective and environmental friendly.

#### Technical data

Rated voltage:	400V~3Ph/PE ±5%
Nominal frequency:	50 Hz
Nominal power:	60 kW
Weight Arch:	285 kg
Weight Rails:	7 kg/m
Sound Pressure Level:	≤ 70 dB(A) at 1 m
Sound power level:	≤ 70 dB(A) at 1 m
Curing temp.:	Max. 170°C
(curing surface)	
Ambient temp.:	Max. 70°C
(in parked position)	
Ambient temp.:	Max. 40°C
(during operation)	

#### 3.1 Layout

Mounting dimensions and vehicle dimensions: see picture below (700908, 700909), all measurements are in mm.

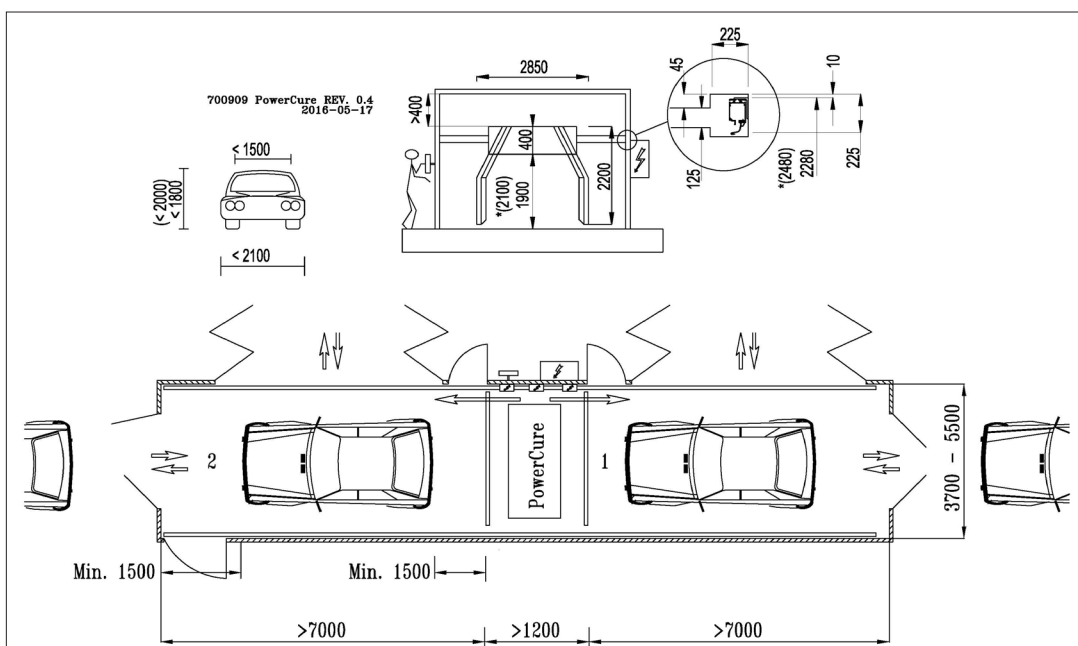
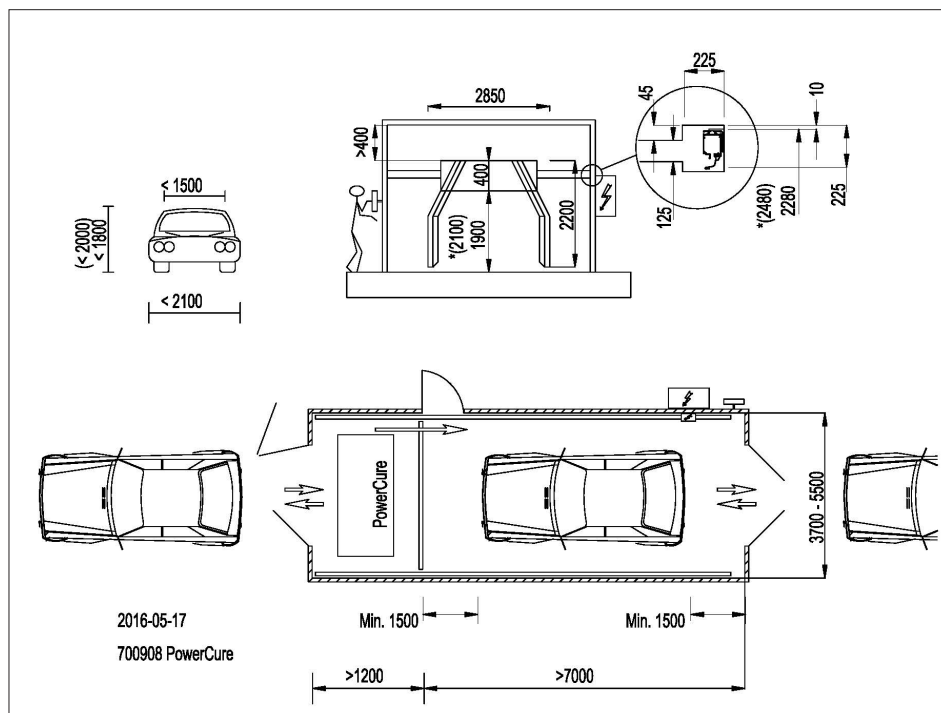

\*Top side rail

### 3.2 Training instructions for operators

Instructions to the owner: in order to meet safety requirements, the owner of the paint curing system must ensure the instructions on arch usage and function are available to those working with the arch. The instructions must be understandable and written in a language that the user understands. These instructions should also be accessible at the work site in a place that is publicly known.

## 4. Safety instructions

### 4.1 General

The facility works with 400 V 3 ~ / PE 50 Hz, which constitutes a lethal voltage! Contact and changes to the electrical equipment must only be performed by electrically qualified persons.

The booth must have technical ventilation (booth aspiration) with an air velocity of at least 0.15 m/s - also during the drying process. The air volume flow has to be sufficient in order to avoid solvent concentrations above 25 % of the lower explosion limit (LEL).

Intensive heat radiation; the paint curing arch must not be used to warm up parts of the body (such as the hands or face) and neither for warming up paint in cans or other containers.

Temperature-sensitive plastic parts must be adequately protected before the curing process starts.

Crushing hazard; Stay outside the booth during movement of the arch. Before starting the process the operator must make sure that there is no other person in the booth. As the arch does not have any proximity sensors, ensure that there are no items within the traversing range and that, during drying, the arch does not collide with the vehicle. For example, markings on the floor could facilitate the correct positioning of the vehicle.

Risk of slipping, tripping or falling; It is the responsibility of the owner to identify the risk of slipping, tripping and falling.

#### 4.1.1 Stop in emergency situation

Equipped with emergency stop at the location of the operator panel. This will disconnect the power to the arch and spray valve.

#### 4.1.2 Breakdown - to release a person caught in the equipment

If a person is caught in the equipment push the emergency stop and push the equipment by hand to release the person.

#### 4.1.3 Operation

No person may be in the spray booth when the PowerCure is in use. The operator must make sure the area is cleared before starting the machine. Before first start up, after installation and service, carry out the acceptance test in accordance with Annex I.

#### 4.1.4 Cleaning

Cleaning of the sensor may be performed with a damp cloth. Do not use running water or flammable liquids.

#### 4.1.5 Disposal

Dispose of used items at the nearest environmental facility for recycling.

### 4.2 System safety

Emergency stop next to the operator panel.

### 4.3 Safety features

Safety switches on all entry doors terminates the process when triggered. Interlocking with exhaust air pressure switch. Double spray valve, monitored by pressure switch. Double main contactors and safety relay. If these protection measures are inactivated or if persons are in the spray booth during operation of the PowerCure, there are risks of clamping/crushing injuries and burns.

## 5. Control of the arch

### 5.1 Operation panel

Switch on the arch via the man switch. The arch is controlled from the control panel which is designed too help you operate the curing process in a simple and convenient way. The panel has a main menu with four different options and various settings (see below).

These are:

Automatic: Preprogrammed programs, see 5.1.1.

Manual: Make your settings manually, see 5.1.7.

Help: Search for help, see 5.1.10.

Setup: Setting tools for the panel, see 5.1.11.

#### 5.1.1 Automatic

The automatic curing option allows you to easily select the desired curing program, and you can then use the same settings on several occasions.

#### 5.1.2 Selection of surface to be cured

Select the drying surface of the vehicle by pressing the respective point. A red mark appears at the selected area. You can cancel your selection by repressing.

#### 5.1.3 Operation mode and choice of booth

Under the option "Booth", you can choose which booth to use for curing. If the workshop only has one booth, the system will display the options "IRT sun" or "spray gun". This is to ensure that you can alternate between curing and painting. If the dryer is intended for two booths, you can chose between the operation modes curing and painting after you have chosen the booth.

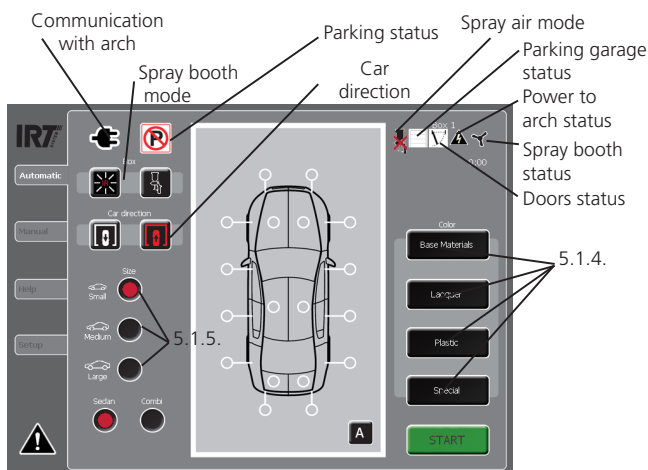

Single booth

### 5.1.4 Selection of coating materials and colour group

Select the type of paint in the menu on the right side panel and select the paint's more specific colour in the dropdown menu.

### 5.1.5 Car size

Select the approximate size of the car to be cured in the size-menu on the panel's left side.

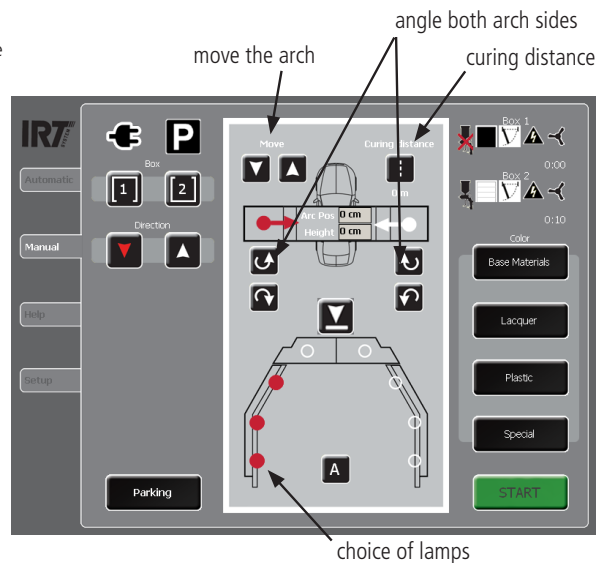

### 5.1.7 Manual

When you select Manual in the main menu on the left you will see options to turn and move the arch manually. After you've done your manual selection, complete the process in the same order as in Section 5.1.4. by selecting the function, curing surface and paint materials.

Curing distance; The curing distance is counted from the start position where the arch has been placed. When you press the curing distance, a number pad pops up where you can choose the travel distance of the arch.

**Note!** When you choose to use this feature, the turn function will be disabled.

Turning and moving; In order to move the arch inside the booth, use the top arrows on the panel. The arch symbol indicates how far from the parking area you have moved the arch. To turn the arch sides, use the rotation arrows on the panel. Every time you make a change, the angle is indicated on the screen.

To return the arch to the parked position, press the "Park" button in the lower left corner on the panel.

Please be careful to avoid collision with the vehicle or other items in the booth, especially during manual turning.

Start the curing process by pressing **START**.

**Warning!** Make sure that no one is inside the booth, and that no combustible material is lying on the floor.

### 5.1.8 Lamp selection

Use the panel picture of the arch to select which lamps you want to use during the curing process. By pressing the "A" button, you can quickly select all lamps.

### 5.1.9 Saved settings

All your manual settings (except for colour selection) will be saved, so they turn up automatically when you are finished and want to start a new process.

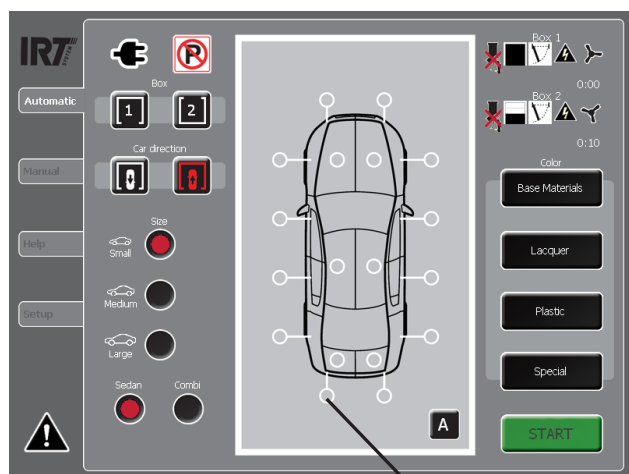

Double booth

### 5.1.6 Saved settings

All your settings (except for colour selection) will be saved, so they are automatically selected when you are finished and want to start a new process.

### 5.1.10 Help

When you select Help from the main menu on the left, you will find this manual in an electronic format.

### 5.1.11 Setup

Setup on the main menu contains various settings to facilitate the use of the panel;

- Show cursor
- View arch status (during curing)
- Automatic lamp test

The configuration options for "Drying recipes" and "Car size" are only available using a PIN code for the advanced user.

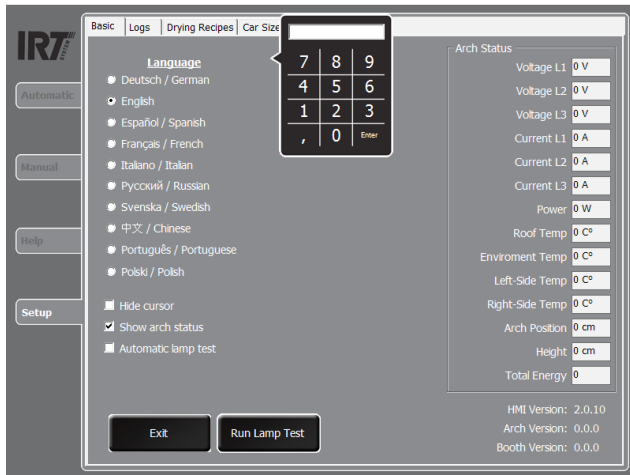

### 5.1.12 Logs

#### Statistics

Statistics of cured sessions. Start, RunTime, Used energy, Time, colour selection, part selection.

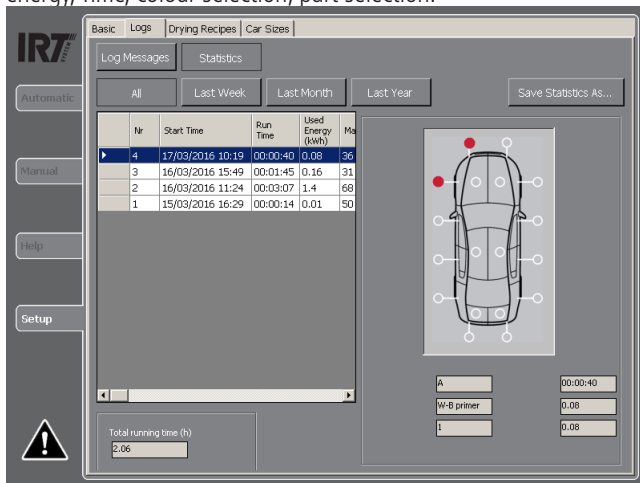

#### Log Messages

List of error messages.

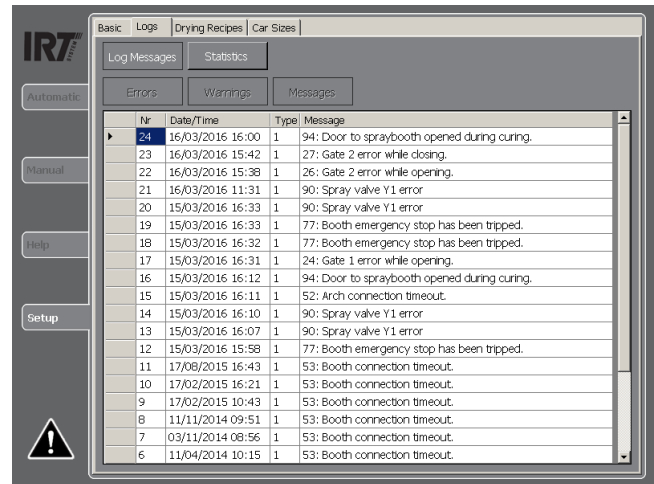

## 6. Start-up / Operation

### 6.1 Before start (Automatic mode)

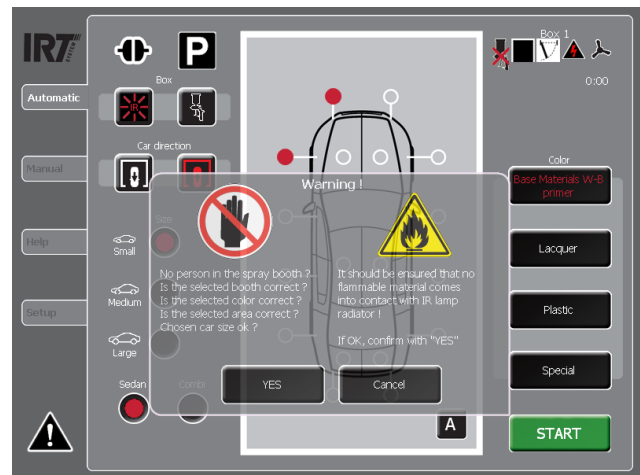

**Please note!** Starting is only possible when the arch is in the parked position. Make sure that no one is inside the spray booth before start.

### 6.2 Start-up

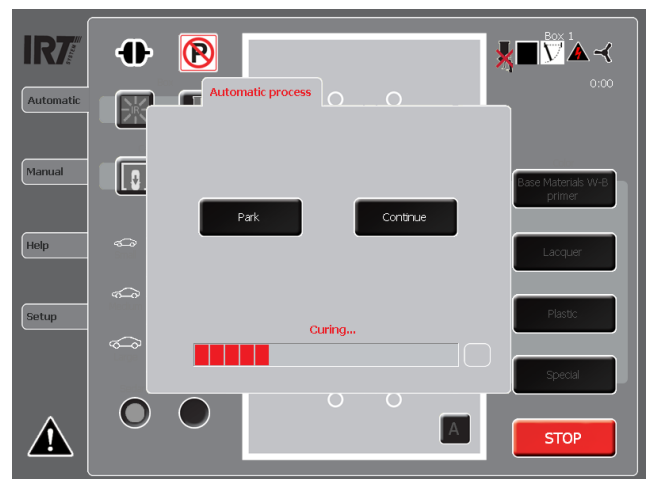

Starting the arch; Carefully check that all settings are properly selected before pressing the **START** button to begin the curing process. The drying process will start time-delayed only if the air in the booth has been changed by the forced ventilation (this takes about 180 seconds)

**NOTE:** If you have more than one spray booth, you must specify which booth you want to use. Make this selection in the upper left corner of the panel.

**Warning!** Make sure that no one is inside the booth, and that no combustible material is lying on the floor.

### 6.3 Operation

Arch position; The symbol P in the upper left corner indicates that the arch is in its parked position. While curing or when the arch is moving, a progress indicator is displayed and the parking symbol is crossed out.

The contact icon in the upper left corner indicates the status of the communication between the arch and equipment outside the booth.

### 6.4 Stop

Stopping the arch; To stop or pause the curing process, press **STOP** in the lower right corner of the panel. When this feature is used, a new menu box is displayed. Press Continue to continue the curing process, or Park to stop it altogether. If you press park, the paint curing arch will return to its parking position.

### 6.5 Resetting after emergency stop

Twist the emergency button and reset the alarm on the operations panel.

### 6.6 Operational data

Machine status; The status of the machine is indicated by the symbols in the upper right corner of as follows:

- Curing / Spraying
- The roller door between the booth and the parking space is open/in motion/closed
- The entry door to the booth is open/closed
- Power to the booth is on/off
- Ventilation for the booth is on (fan symbol rotates)/ off (fan symbol does not rotate)

### 6.7 Operation interference

See illustrations on page 4-5.

## 7. Care and maintenance

### 7.1 General

**NOTE!** All maintenance and repairs should only be performed by trained and qualified personnel and only when the machine is in a non-energized state. Switch off power supply and lock the main switch. Break the air supply and vent out the pressurized air.

Use a four-legged ladder / platform at the service of the parts situated in the roof part of the arch. It is the responsibility of the user to ensure this.

Maintenance work is only to be carried out at the stipulated intervals by suitably trained personnel. Do not use running water or flammable liquids. Abide by the following points to ensure a long service life and continuous operation of the

PowerCure:

- Only original spare parts may be used
- Adhere to the maintenance intervals
- Contact the manufacturer's customer service department regarding any maintenance work that is not listed or shown in this or the extended service manual (701035).

### 7.2 Trouble Shooting

#### Drying does not start

- Check alarms
  - Roller door in wrong position (down) (closed) (indicated on the panel)
  - No power supply, turn on the main switch and check the fuses.
  - Check the fuses in the monitoring cabinet and arch.
- Note! This may only be performed by qualified personnel.
- Entrance doors to spray booth are not closed.
  - Ventilation time still counting.

#### No compressed air in the booth before/after drying;

- Check alarms
- Select "Spraying" as described in the 5.1.3 Operation mode and choice of booth".
- The arch is not in the parked position. (Indicated on the control panel)
- Roller door at the parking position is not completely closed. (Indicated on the control panel)
- Check the voltage supply. (Indicated on the control panel)

### 7.3 Maintenance schedule

#### Monthly or after 400 curing, whichever comes first

- Check that the gold foil of the reflectors is not damaged or heavily soiled and that all light lit up during operation. Damaged or soiled foils should be replaced to maintain proper heat distribution.
- Check that the PowerCure Arch is moving smoothly, tension the spring at the driving wheel if necessary.

#### Quarterly or after 800 curing, whichever comes first

- Check that the gold foil of the reflectors is not damaged or heavily soiled and that all light lit up during operation. Damaged or soiled foils are replaced to maintain proper heat distribution.
- Check that the PowerCure Arch is moving smoothly, tension the spring at the driving wheel if necessary.

#### Yearly or after 2500 curing, whichever comes first

- Check that the gold foil of the reflectors is not damaged or heavily soiled and that all light lit up during operation. Damaged or soiled foils are replaced to maintain proper heat distribution.

- Replace the driving wheels on both sides and Control the travel of the arch. Part number for order: 713967. Loosen the tension spring at the driving wheel on both sides and check that the arch is still is traveling smoothly before tensioning the travel wheel again. The force needed to push the arch by hand should not exceed 200N (20kg).
- Check that the PowerCure arch park perpendicular (90 degrees angled) to the rails. If not adjust the parking sensor position until it park completely perpendicular to the rails. Control also that the sensors work properly and are well fixed and clean.
- Check the roller port sensors work properly and are well fixed and clean
- Check the ventilation sensor work properly and are well fixed and clean.

### Tools for Service and maintenance

The following tools are needed for the installation:

Tool	Size	Qty
Socket wrench kit	metric	1
Box-end wrench	10 mm	1
Box-end wrench	13 mm	2
Box-end wrench	18 mm	2
Screwdriver Philips	2	1
Screwdriver flat	2, 3, 4, 6 mm	1 ea
Allen key	4, 5, 8 mm	1 ea
Pointed pliers		1
Cutting pliers		1
Multimeter		1
Measuring tape	(Booth width)	1
Level instrument (laser)	(Booth length)	1
Ladder, fourlegged	Suitable for working height 2,5 m	1
Forklift	>350 kg	1
Protection gloves		2 pairs

### Replacing the IRT lamps

**WARNING!** Before any intervention in the system, the voltage must be disconnected. Do not remove the protective cover of the lamp until the IRT lamp is mounted.

1. The protective grille is attached at both ends with screws. Loosen them until the fastening plates become loose (see Figure 7.1).

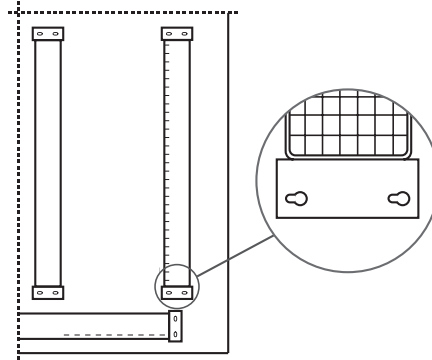

Figure 7.1.

2. Push the protective grille to the side and remove it.
3. The lamps are secured by a screw at each end. Loosen them so far as to free the lamp ends (see Figure 7.2)

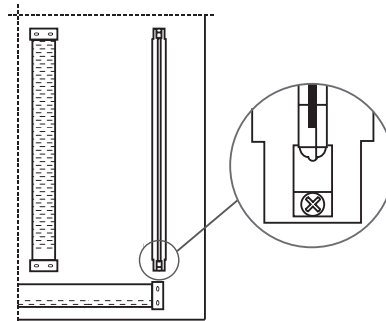

Figure 7.2

4. Pry up the lamp holder using a screwdriver. The lamp can now be removed and replaced (see Figure 7.1.3).

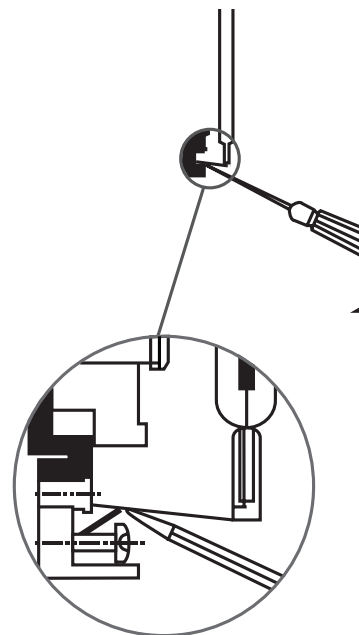

Figure 7.3

**IMPORTANT!** Never touch the glass or reflectors with your hands.

5. Install the new lamp in the upper bracket. Make sure the holder goes in as far as possible under the square washer.



6. Tighten the screw. Bend the bracket at the lower end of the lamp by hand and attach it the same way as the upper one.
7. Center the IRT lamp in the reflector body both longitudinally and laterally.
8. Remove the protective cover from the IRT lamp.
9. Refit the protective grille.

**Tightening the drive wheel**

If the drive after a while begins to slip:

1. Check that the wheel and the aluminum rail are clean
2. Make sure the rails are still properly aligned
3. Increase the wheel pressure against the rail

Tension the spring using an 18 mm key until the drive wheel is not slipping.

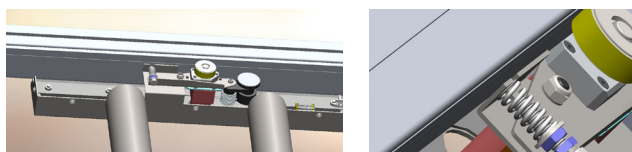

(For extended service, see «IRT PowerCure» art nr 701035)

## 8. Installation and transport

### 8.1 Installation

The control panel must be located outside the booth in a place with full visibility into the booth (e.g. close to an inspection window). In case that the arch is intended for the use in two booths, both booths must be completely visible (e.g. by mounting on a swinging arm). In such a case the booths must be clearly and good visibly assigned to the respective selection possibility in the control panel ("1" or "2")

**Note:** The parked paint curing arch must not limit any escape route!

The booth must have the needed spatial capacities for parking the arch in a position protected from spraying fog. This might be for example a port between two subsequent booths. Otherwise the lifetime of both the IR-lamps and the arch in general will be significantly reduced.

**Electric installation**

The electrical installation must be performed by an electrically qualified installer or by someone under his supervision and monitoring.

Before you start the installation, read necessarily the assembly instruction manual (document 701001) and follow all described advices and specifications.

**NOTE**

The installation must comply with applicable regulations.

Check items prior to start up

1. Installation verification of the mechanical part by the responsible installer (Annex I, Mechanical Part).
2. Inspection of the power supply and electric installation (Annex I, Electric part).
3. Prepare a log of the results from initial commissioning and submit one copy to both the workshop management and the system supplier

### 8.2 Transport

Transport of crates to site of installation with the help of fork lift.

## 9. Specifications

### 9.1 Technical information

See chapter 3. Product description

### 9.2 Noise and vibration

See chapter 3 Product description

## 10. Spare parts list

### 10.1 Spare parts list

Mechanical spare parts			
Part No	Description	Req. No. In Stock	Drawing (see 701035 Extended service and maintenance manual)
713967	Driving Wheel Ø57 Mm	2	713599
800196	Reflector Complete	1	713590/ 713700
710695	Protection Net	2	713599
Electrical			
102701	Irt-Lamp 790 3 Kw	2	713590/ 713700
180521	Limit Switch Irt-7000	2	713599
713547	Transport Motor Unit	1	713599
750409	Op Powercure	1	
193092	Distance Sensor Laser Ifm	1	713700
129027	Fan	1	713700/ 713590
122437	Sensor Ind	1	713700
750300	Transformer 230/400/480 Vac/12Vdc	1	713700
195368	Contactactor 80A 230V	1	750410
180520	Voltage Suply Unit	1	750410
129014	Plc Ethernet Bc9100	1	750410
129015	I/O D-In 8Ch	1	750410
129024	I/O D-In 4Ch	1	750410
129026	I/O Power Measure	1	750410
195392	Relay 2- Pol 24 V	1	750410
129022	I/O D-Out 8Ch	1	750410
713534	Turning Drive Unit	1	713534
193942	Solid State Relay	1	750410
For other electrical parts see Electrical Diagram			
Expandable Parts			
713967	Driving Wheel Ø57 Mm	2	
102701	Irt-Lamp 790 3 Kw	2	
713248	Protection Foil Operation-panel	2	

## 11. Electrical drawing

See 750410 - PowerCure

## 12. Certificate of conformity

We,

### **HEDSON TECHNOLOGIES AB**

Hammarvägen 4  
SE-232 37 ARLÖV  
Sweden

declare under our sole responsibility that the product:

IRT PowerCure

that this declaration relates to conform with the following standards or other normative documents:

SS-EN 60204-1, EN 12100-1, EN12100-2

EN 61000-6-3, EN61000-6-2,

EN 1539, EN 13355,

SS-EN ISO 9001

SS - EN ISO 13857

under the terms of the following directives

Machinery Directive 2006/42/EC

Directive 2014/30/EU on Electromagnetic Compatibility

Arlöv, Sweden March 3rd, 2016

HEDSON TECHNOLOGIES AB

Technology Division



Magnus Björnström

CEO

# 1. ANNEX I, Acceptance test

Acceptance test carried out by the responsible assembler / electrician prior to commissioning.

System	Type
Ref.	Software version
Issued by	Date

Copy for the system supplier

## 1.1 Mechanical part

### Monitoring device and operator station

- Located outside and near the booth.
- The inside of the booth is visible from the control panel.

### Rails

- Same height (horizontal  $\pm 2$  mm) \*
- Steady and securely fastened.
- Satisfactory strength.
- Contact rails well protected by labyrinth seal.
- The arc moves freely throughout the area.

### Warning signs

- Signs «Unauthorized persons may not enter» mounted on all entry doors.

### Parking position

- Parking position sensor is functioning and properly installed.
- Parking arch is steadily and firmly secured
- The arch is easy to drive in.
- The arch is well protected in the parked position.
- Temperature switch mounted

### Negative pressure switch in exhaust air duct

- Adjusted for proper operation.
- Max 2 m hose length.
- No formation of water pockets in the hose.

### Safety

- Emergency stop installed at operator's panel.
- Entry door switches mounted on all entry doors.

\*) Floors often incline more than 2 mm Use a spirit level (preferably with a laser)

## 1.2 Electrical part

### Visual inspection

- Power supply properly fused.
- The main cable to the monitoring unit 4 x .....mm<sup>2</sup>.
- Protected main terminals.
- Sealed lead-ins.
- PE and other terminals securely connected.
- Correctly connected bus bar (PE!).
- Conductor rail IP 4 x.
- Correctly connected arch (PE!).
- Correctly connected operator panel (PE!).

Measurements according to EN 60204-1 / VDE 0113-1, Chapter 18.

Carrying out with measuring instrument (manufacturer, Type, Series-No.):

- ..... Value: .....
- ..... Value: .....
- ..... Value: .....

### Funktion test with power

- Main switch on.
- Exhaust air on.
- Solenoid valve on (spray air on) with the arch in the parked position and spraying selected.
- Solenoid valve off (spray air off) when IR curing is selected
- Fans of the arch start when lamps light up.
- Position switch in the parking position securely fastened.
- All lamps can be switched on
- The arch's two sides can be rotated in both directions
- The arch can run over the full surface, without jerking or the drive wheel slipping at high / low speed
- Emergency stop
- Entry doors switches



701006 Rev 6

**HEDSON TECHNOLOGIES AB**

Hammarvägen 4, SE-232 37 ARLÖV, Sweden  
Tel. +46 40 53 42 00  
Fax +46 40 43 29 01  
[www.hedson.com](http://www.hedson.com)

**HEDSON TECHNOLOGIES AB**

Box 1530, SE-462 28 VÄNERSBORG, Sweden  
Tel. +46 521 281000  
Tel. +46 521 66909  
[www.hedson.com](http://www.hedson.com)