

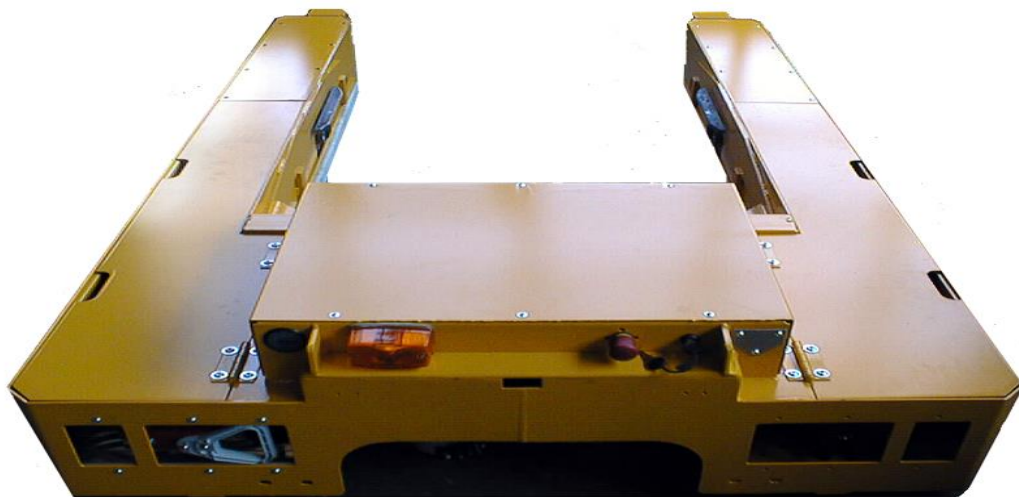

# Operating Instructions and Inspection Log for Transmobil

Machine-Type	Article-No.	Serial-No.
Transmobil	HLT-03	



Herkules Hebeteknik GmbH  
Miramstraße 68b  
D - 34123 Kassel  
Tel.: +49 (0)561 58907-0  
Fax: +49 (0)561 58907-34  
Email: info.de@hedson.com  
Internet: www.hedson.com



760-079\_HLT-03\_2017.11\_3.1\_ENG  
Translation of german original version



---

## Table of Contents

1	Function and Safety Check .....	5
2	General Information.....	6
2.1	Hazard Indications.....	6
2.2	Limitation of Liability .....	6
2.3	Copyright.....	7
2.4	Terms of Guarantee .....	7
2.5	Customer Service.....	7
3	Product Description .....	8
3.1	Intended Use .....	8
3.2	Product structure .....	9
3.3	Technical Data .....	10
3.4	Product Designation.....	10
4	EC Declaration of Conformity .....	11
5	General Safety Instructions .....	12
5.1	Operator´s Duty of Care .....	12
5.2	Operator´s Duties .....	12
5.3	Basic Safety Measures.....	13
5.4	Requirements of Operating Personal .....	14
6	Transport and Preparation.....	15
6.1	Transport Inspection.....	15
6.2	Disposal of the Packaging Materials .....	15
7	Operation.....	16
7.1	Description of Control Elements.....	16
7.2	Commissioning.....	17
7.3	Operate .....	18
7.3.1	Turn On .....	18
7.3.2	Control.....	18
7.3.3	End of Work.....	18
7.4	Lift and Carry of the HLS-Lifting Platform.....	19
7.5	Battery.....	20
7.6	Charging Transmobil.....	21
8	Troubleshooting.....	22
8.1	Possible problems and their resolutions.....	22

---

---

8.2	Reading the Error Code .....	23
8.3	Check Radio Remote Control Fuse.....	23
9	Maintenance Battery .....	24
10	Safety Inspection.....	25
10.1	Regular Safety Check .....	26
11	Disassembly and Disposal .....	27
11.1	Disassembly.....	27
11.2	Disposal .....	27
12	Additional Information.....	28

---

# 1 Function and Safety Check

**carried out by the manufacturer to check the following details:**

**Following plates present:**

- Nameplate
- Lifting capacity
- Company logo
- CE- marking
  
- Operating Instruction! (present)**

**Operation and safety checked:**

- Functional test without load
- Function test with lifting platform and vehicle

**Tested:**

- All bearing screws are firmly seated
- Steering drive function
- Wheel drive function
- Brake function
- Radio remote control function
- Electrical system and battery function
- Condition of load-bearing structure

Manuf. no.: \_\_\_\_\_

Date: \_\_\_\_\_

Name: \_\_\_\_\_

Herkules Hebeteknik GmbH  
Miramstraße 68b  
D 34123 Kassel  
Tel.: +49 (0) 561/58907-0  
Fax: +49 (0) 561/58907-34  
Email: info.de@hedson.com

## 2 General Information

The operating instructions (and test log book) contain important information concerning the installation, and ensure safe, proper, and economical operation as well as preservation of operational safety. Observance of these operating instructions will help you to avoid danger, reduce repair costs and downtime as well as to increase the life of your service lift.

As evidence of regular **safety checks** this test log book contains a form. This should be used to provide documented details of tests. (It is advisable to make a copy of the form before starting to fill it out.)

### Installation and testing

Safety-related work and safety inspections may only be performed by suitably trained personnel. In this documentation, personnel are designated as expert and qualified persons.

### 2.1 Hazard Indications

The following symbols are used to indicate danger points and to highlight important information. An explanation is given of their meanings. Please pay particular attention to areas of the text containing a symbol of this nature.



**This describes a hazard to life or severe injury. There is a severe hazard of mortal injury if the procedure described is not carried out correctly.**



**This indicates a key function or an important note!**

### 2.2 Limitation of Liability

All details and indications in this operating manual were compiled taking into account the applicable standards and regulations, and the latest technology as well as our many years of insight and experience. The manufacturer accepts no liability for any damage caused by:

- Failure to adhere to the operating manual
- Improper use
- The intervention of non-qualified staff
- Arbitrary alterations
- Neglecting maintenance

---

## 2.3 Copyright

These operating instructions are to be treated as confidential and are solely intended for personnel working with the machinery. Transfer of the operating manual to third parties without the written consent of the manufacturer is prohibited.



**Text, drawings, images and other illustrations are copyrighted and intellectual property rights apply.**

## 2.4 Terms of Guarantee

The terms of guarantee are included as a separate document in the sales brochures.

## 2.5 Customer Service

For technical information, please contact our customer service centre as follows:

<b>Customer Service:</b>	Herkules Hebetchnik GmbH Miramstraße 68b D – 34123 Kassel Tel.: +49 (0)561 58907-0 Fax: +49 (0)561 58907-34 Email: <a href="mailto:info.de@hedson.com">info.de@hedson.com</a>
--------------------------	--

## 3 Product Description

### 3.1 Intended Use

The Transmobil is a rail-independent electric vehicle for the transporting vehicle lifting platforms with and without cars.

The Transmobil is designed for the acceptance of lifting platforms with a load of up to 2500kg. The applied load shall not exceed the allowable capacity of the Transmobil 2500 kg + lifting Platform.

The transporting of persons or other objects is not allowed (even on the lift or in the car).

Intended use includes also reading the manual, and complying with all information contained therein - especially the safety instructions.

That include that all inspections and maintenance are carried out in the prescribed time intervals.

If the Transmobil not used in accordance with this provision no safe operation is ensured.

For all personal and property damage resulting from improper use, is not the manufacturer, but the operator responsible.



## 3.2 Product structure

The transportation system includes an Transmobil and a HLS-lifting platform. The cars remain on a lifting platform throughout the movement, making it possible to move them quickly and safety to the next work station

The Transmobil consists of a U-shaped frame with four pick-up points to accept the lifting platform, an electric steering drive with four batteries, and a remote control unit. The shape of the Transmobil is designed to suit the HLS lifting platform. In order to pick up the lifting platform, the Transmobil is moved to beneath the raised platform. The lifting platform is then moved until the upper frame settles onto the four pick-up points on the Transmobil, and the lower frame is raised.

The Transmobil is operated via the remote control unit. The operator can change the position of the Transmobil using the remote control, so is able safely to control it at all times, without danger to himself.

When using the Transmobil, be aware of any ambient influences that could have an effect on the electronics.

The Transmobil is also equipped with a number of safety features. These include the key-operated switch, EMERGENCY OFF switch and the warning lights.

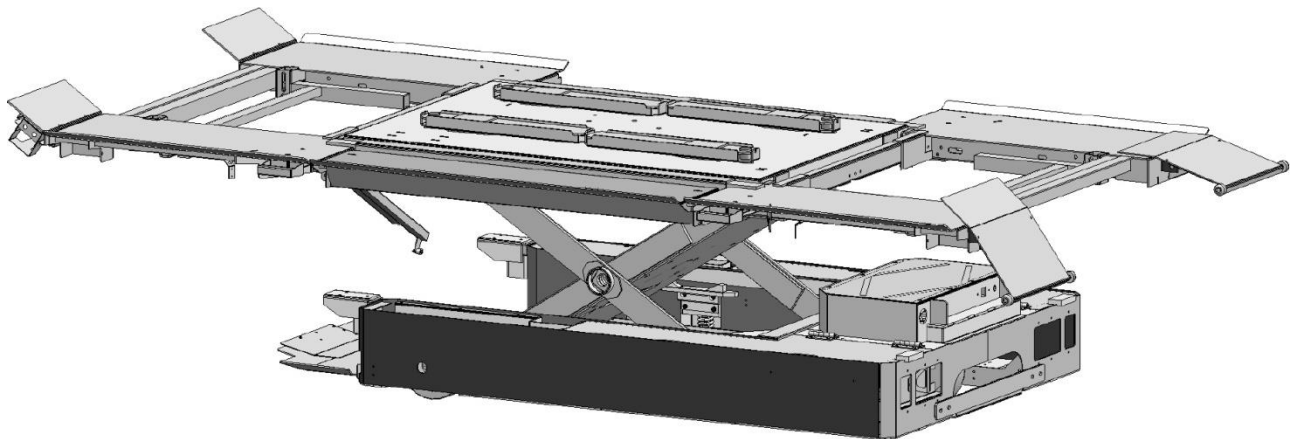

*Image1: Transmobil HLT-03 with lifting platform in accept position*

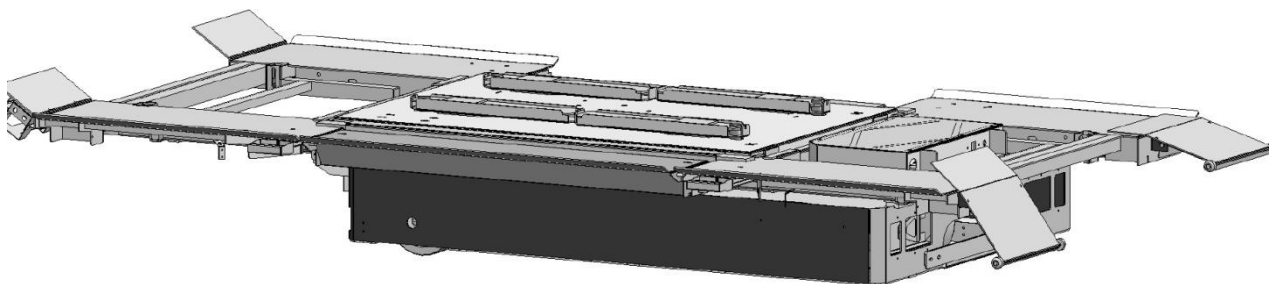

*Image 2: Transmobil HLT-03 in driving position*

### 3.3 Technical Data

Technical changes reserved.

<i>Subject to technical changes.</i>	<b>HLT-03</b>
Load capacity	HLS lifting platform + 2500kg payload
Height of structure	456 mm
Length	2319 mm
Width	1450 mm
wheelbase	1583 mm
Gauge	1233 mm
Total weight	approx. 600kg
Drive power provided by 4 batteries, each	12V
Steering drive	via gear motor and brake
Mains voltage for battery charger, supplied by customer	230V
Noise load below	70dB(A)

<b>Safety devices</b>	
Brakes	yes
Key-operated switch	yes
EMERGENCY OFF switch	yes
Warning lamps	yes
Signal horn	yes

### 3.4 Product Designation

The details of the lifting platform are stated on the type shield on the machine frame as well as in the EC Declaration of conformity.

Details Name Plate	Article No.		Year of construction	
	Machine type		Operating pressure	
	Serial No.		Vers.	
	Lifting capacity		Empty weight	

## 4 EC Declaration of Conformity

The manufacturer	<b>Herkules Hebetchnik GmbH</b> <b>Falderbaumstraße 34</b> <b>34123 Kassel</b>			
Responsible for documentation	<b>Herkules Hebetchnik GmbH</b>			
is responsible for the documentation and declares that the following machine described,	<b>Transport System</b>	<b>Machine- Type</b> <b>Transmobil</b>	<b>Art.- No.</b> <b>HLT-03</b>	<b>Serial- No.</b> <b>See cover page</b>
complies with the Health and Safety requirements of the following EC directives:	<b>EC Machinery Directive 2006/42/EC</b> <b>EMC Directive 2014/30/EU</b> <b>Low Voltage Directive 2014/35/EU</b>			

Kassel, 19.09.2017

Location, Date



Dirk Meinzer, Managing Director

## 5 General Safety Instructions

### 5.1 Operator's Duty of Care

The Transmobil has been designed and built to comply with the results of a hazard analysis, carefully selected harmonised standards to which the device must comply, and other technical specifications. It therefore corresponds to the latest state of technology and ensures the maximum level of safety.

This level of safety can be achieved in operation only if all the necessary procedures have been undertaken. The operator of the Transmobil has a duty of care to plan for these procedures and to ensure that they are complied with.

In particular, the operator must ensure the following:

- that the Transmobil is used only for the intended purpose (see section entitled "Product Description").
- that the Transmobil is operated always in perfect and properly functioning condition, and that in particular the safety devices are regularly checked for correct function.
- that the operating instructions are kept in a legible condition, and that they are available, complete, at the location where the Transmobil is deployed.
- that only sufficiently qualified and authorised staff are allowed to use, operate and repair the Transmobil.
- that these persons receive regular instruction in all matters concerning work safety and environmental protection, and that they are fully aware of the operating instructions, and in particular, the safety information contained therein.
- that the Transmobil will not be operated in a potentially explosive area
- the ground strap is properly attached so that electro-static discharge is ensured. (the ground strap must be in contact with the ground).
- that the safety and warning notices attached to the Transmobil are not removed, and that they remain legible at all times.

### 5.2 Operator's Duties

The operational safety regulations provide a number of measures for the operator of work equipment for use in hazardous area.

The operator must conduct a risk assessment of the area in which the working equipment is to be used. It should be recognized and addressed the hazards that can be caused when using the work equipment in association with the working substances and the work environment.

The operator shall take the necessary measures and selects the one manufacturing resources which are suitable for the conditions in the workplace and ensure that the intended use is safe and hygienic.

For the implementation of risk assessment and the selection of suitable equipment, the operator must use the country-specific regulations and standards.

## 5.3 Basic Safety Measures



When handling the Transmobil you must observe all statutory accident prevention regulations, with regard to BGV A 1 (General regulations) [Germany] and BGV A 2 (Electrical Equipment and Operating materials) [Germany]



The Transmobil must not be allowed to stand in paint-spray cabins during the painting and drying processes, due to the risk of explosion. Before the Transmobil is moved into it, the paint-spray cabin must be well ventilated.

We draw your attention in particular to the following regulations:

- The total weight (the HLS-lifting platform complete with car) must not exceed the prescribed load capacity, and the overall centre of gravity must be above the running wheels.
- The ground on which the Transmobil operates must be even and dry. If the Transmobil will be operated on a sloped base (such as a ramp), please get in touch with the manufacturer.
- Always observe the operating instructions when operating the Transmobil.
- Only people who are over the age of 18 and who have received full instruction in operating the Transmobil are authorised to use it without supervision.
- The operator must watch the HLS lifting platform (complete with lifting table and car where appropriate) throughout the entire lifting, movement, and descent procedure.
- before accepting the lifting platform it must be ensure that the wheel-free function of the lifting platform (see separate manual HLS lifting platform) is not active.
- The intermediate tracks of the lifting platform must be raised (see separate manual HLS lifting platform).
- Apart from the operator, no person is allowed to be within the working area of the lifting platform during the lifting or descent procedures.
- The Transmobil can only be driven under the lift by the ramp side.
- No person may be carried on the Transmobil (the lifting platform or inside the vehicle).
- Climbing onto the lifting platform or onto the lifted vehicle is prohibited.
- When moving the Transmobil, always act with great care, anticipating any hazards.



**Disregarding the instructions may lead to serious personal injury and damage to the Transmobil or the lifting platform and load.**

## 5.4 Requirements of Operating Personal

The Transmobil must be operated only by persons who are trained, instructed in its use, and authorised to do so. Such persons must be well aware of the operating instructions and must act accordingly. The various levels of authority of operating personnel must be set out clearly.

Moreover, for the following activities, specific qualifications are required:

Operation	Execution
Installation	Herkules service assemblyman / qualified person
Starting up	Herkules service assemblyman / qualified person
Briefing	Herkules service assemblyman / qualified person
Fault clearance	Herkules service assemblyman / qualified person
Servicing	Herkules service assemblyman / qualified person
Maintenance	Herkules service assemblyman / qualified person
Repairs	Herkules service assemblyman
Disassembly	Herkules service assemblyman / qualified person

Operating individuals in training should only operate the lifting platform when supervised by an experienced person. Evidence of completed and successful training should be confirmed in writing.

All control and safety installations must, generally speaking, only be operated by suitably trained persons.

All individuals engaging in activities involving the lifting platform must read the operating instructions and sign to confirm that they have understood them.

---

## 6 Transport and Preparation

### 6.1 Transport Inspection

Check the order upon receipt of delivery for damages caused during transport.  
If there is identifiable damage, proceed as follows:

- Leave the goods and packaging in an unchanged state. Do not attempt to use the product.
- Immediately contact Herkules customer service.

**Customer service:** Herkules Hebetchnik GmbH  
Miramstraße 68b  
D - 34123 Kassel  
Tel.: +49 (0)561 58907-0  
Fax: +49 (0)561 58907-34  
E-mail: info.de@hedson.com



**Do not send back damaged goods before receiving confirmation from the customer service centre!**

### 6.2 Disposal of the Packaging Materials

The packaging material must be disposed of in accordance with the current environmental - and disposal guidelines.

## 7 Operation

When operating the Transmobil, the following safety instructions and the safety instructions in section “**General Safety Information**” must be followed without fail. This will prevent severe injury to personnel, damage to the machine and other material damage.

The Transmobil may only be used according to its intended use. Inform yourself before using the Transmobil how to behave in case of incidents.



**People who work with the Transmobil must wear safety boots and be familiar with the operating instructions.**

### 7.1 Description of Control Elements

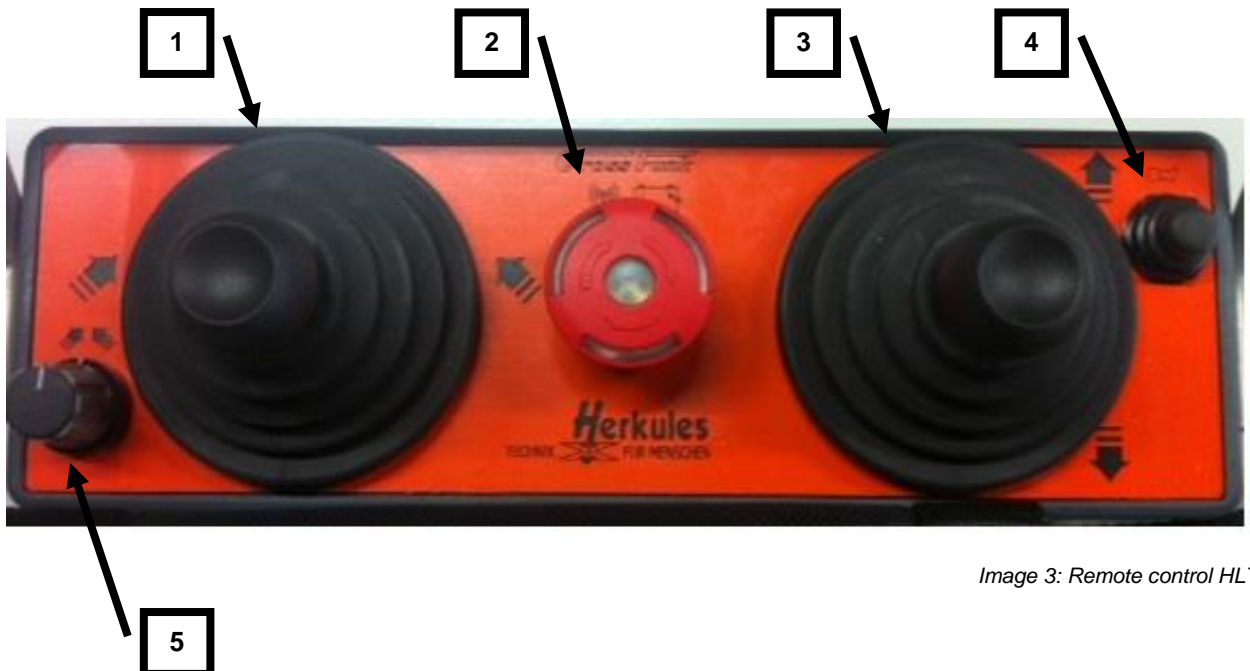

Image 3: Remote control HLT-03

No.	Description	Information
1	Joystick steering motion	
2	Emergency Stop / Main Switch	LED-Display (Off=Off / On=transmitter on / flashing=battery empty)
3	Joystick feed motion	In the 0 position, the spring-applied brake is active
4	Signal horn	
5	Fine tuning Straight run	

The Transmobil comes with a radio remote control. The radio remote control has two joysticks which controlled the feed and the steering movement of Transmobil. The Transmobil comes with a wireless remote control. The radio remote control has two joysticks on the feed and the steering movement of Transmobil controlled. Other features include an emergency stop, which also acts as the main switch, and the actuation of the horn. In addition, via the remote control to fine tune straight running.





Additional information about the remote control, such as proper charging of the battery, refer to the manual **Gross Funk** in the appendix.



## 7.2 Commissioning

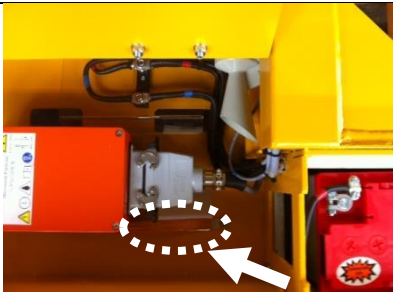
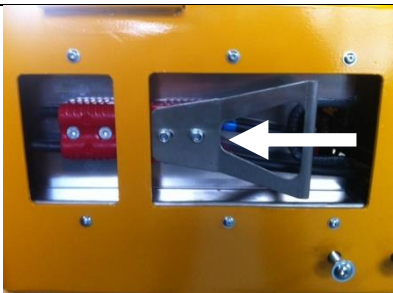
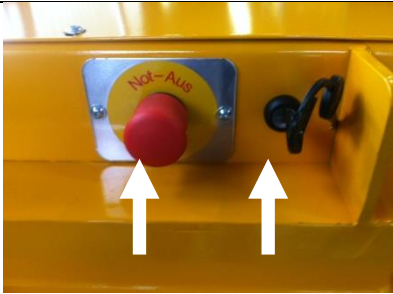

The security measures in the chapter "General safety Information" must be read carefully before and must be observed during the handling.

No.	HLT-03	Description	Information
1	/	<ul style="list-style-type: none"> <li>Remove Transport packaging</li> <li>Lift Transmobil with a suitable lifting equipment (forklift) from the transport pallet</li> </ul>	Observed chapter "Disposal of packaging materials"
		<ul style="list-style-type: none"> <li>Disconnect grounding cable from the transport position. (Ground contact must be guaranteed).</li> </ul>	The ground cable is located in the right battery case under radio remote control. (See picture).
3		<ul style="list-style-type: none"> <li>Insert the battery connector.</li> </ul>	see chapter „Battery“
4		<ul style="list-style-type: none"> <li>Unlock the emergency stop switch on Transmobil.</li> <li>Unlock the key switch on Transmobil</li> </ul>	<b>The starting sequence is mandatory.</b>
5		<ul style="list-style-type: none"> <li>Unlock Main switch (emergency stop) on radio remote control.</li> </ul>	<b>The starting sequence is mandatory.</b>

## 7.3 Operate

The security measures in the chapter "**General safety information**" must be read carefully before operating and must be observed during handling.



**During the driving process keep constantly eye contact with the Transmobil and the affiliated lifting platform.**



**The activation sequence is mandatory!**

### 7.3.1 Turn On

- Plug in Battery plug on Transmobil (Check fixed seat).
- Unlock emergency stop on Transmobil.
- Unlock the key switch on Transmobil.
- Unlock the Main switch (emergency stop) on remote control.
- Check the charging status of the Transmobil battery (See "**Battery information**").
- The Transmobil is ready.

### 7.3.2 Control

- To operate the Transmobil use the two joysticks (feed, steering motion) of the remote control (see "**Description of the control Elements**").
- Releasing the feed motion joysticks (automatically returns to zero), the Transmobil start to brake.
- In the zero position, the spring-applied brake prevent the Transmobil from rolling.
- Information for right use of acceptance and process HLS lifting platform refer to chapter "**HLS lifting platform acceptance and process**".

### 7.3.3 End of Work

- Stop Transmobil at a suitable parking position.
- Press Main switch (Emergency-stop) from radio control (LED is off).
- Lock key switch on Transmobil.
- Secure Transmobil against unauthorized use (remove key).

## 7.4 Lift and Carry of the HLS-Lifting Platform



The necessary security measures, as well as the instructions for proper use of HLS lifting platform, refer to the respective lifts manual. These are mandatory!



The security measures in the chapter "General safety information" must be read carefully before operating and must be observed during handling.



During the driving process keep constantly eye contact with the Transmobil and the affiliated lifting platform.

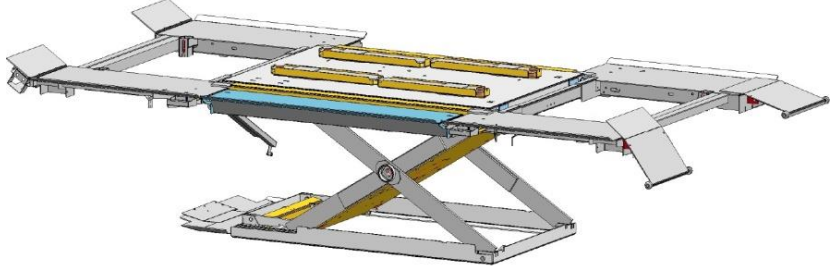
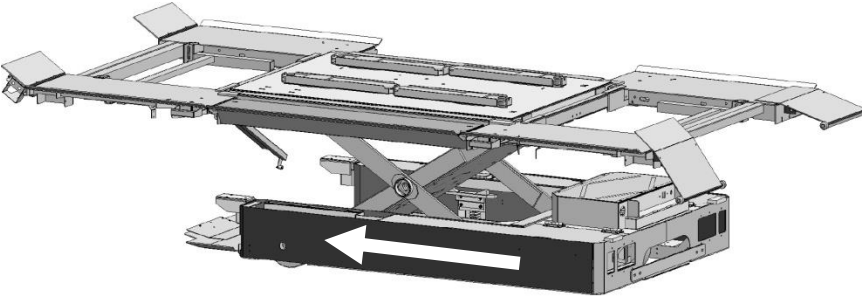
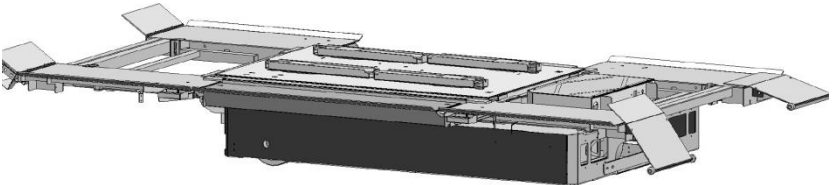

The Transmobil can only be driven under the lift by the ramp side.

Description	Picture
<ul style="list-style-type: none"> <li>• Move the lifting platform to the upper end.</li> <li>• Between tracks as well the DUO supports must be raised.</li> <li>• The wheel-free function of lift may not be active.</li> </ul>	
<ul style="list-style-type: none"> <li>• Observe entry direction (See arrow)</li> <li>• Drive Transmobil carefully to the stop under the lifting platform.</li> </ul>	
<ul style="list-style-type: none"> <li>• Lower lifting platform until <b>the lower frame is completely free</b></li> <li>• Ensure that the lifting platform properly seated on the mounting points of Transmobil.</li> <li>• Disconnect the air supply to the lifting platform.</li> </ul>	

## 7.5 Battery

### Battery level and number of hours

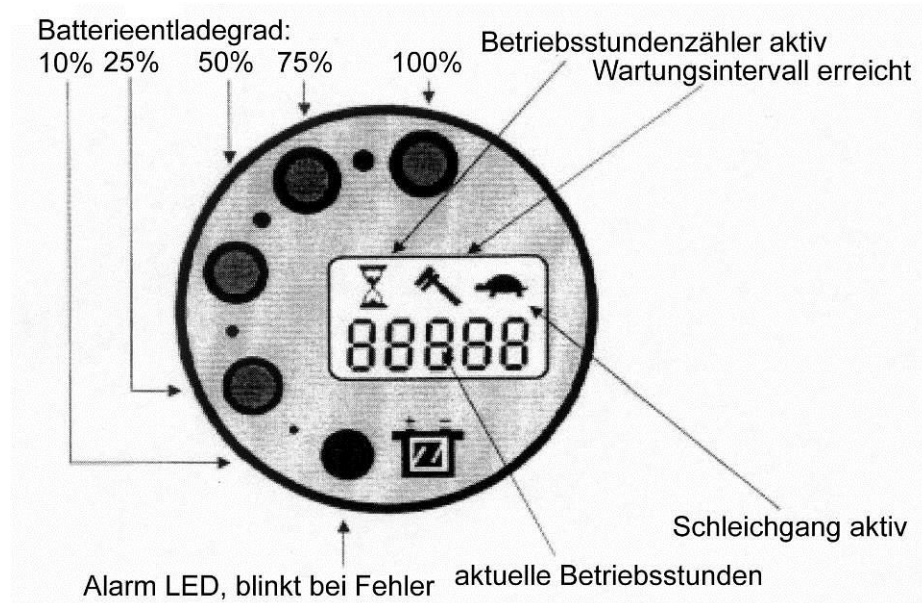

#### Comment:

The battery has a certain capacity and it depends on the temperature and on the current taken. As lead acid batteries discharge the acid density degrades, which means that conductivity becomes too low if a battery is deep discharged. We therefore recommend that you should constantly charge the batteries as often as possible, but at the latest when only one green indicator light is lit on the display (MDI). Discharges made in the electrolyte freezing zone can cause the battery to be destroyed.

The final discharge voltage is the specified voltage, below which it must not fall when discharging at the attributed current. If, despite this, the batteries continue to discharge (i.e. the battery voltage is lower than the final discharge voltage), the deep discharge zone begins. The battery will also go into the deep discharge zone if the battery regenerates itself by pausing during discharge, and thus, when it reaches the final discharge voltage, is too deeply discharged.

The battery capacity taken is described as the discharge depth.



The battery is protected against deep discharge.



Even when not using the Transmobil check the charge state of the battery at regular intervals and recharge as appropriate.

## 7.6 Charging Transmobil

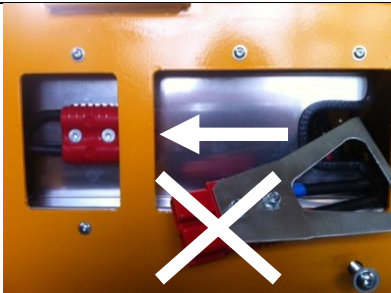

The security measures in the chapter "General safety information" must be read carefully before the battery charging and must be observed during handling.

No.	HLT-03	Description	Information
1	/	<ul style="list-style-type: none"> <li>Shut off Transmobil.</li> <li>Provide adequate ventilation.</li> </ul>	See Chapter „Operate“
		<ul style="list-style-type: none"> <li>Disconnect battery plug</li> </ul>	
3		<ul style="list-style-type: none"> <li>Connect the battery charger to battery (see arrow)</li> </ul>	
4		<ul style="list-style-type: none"> <li>Switch on the battery charger.</li> </ul> <p><b>Important: Set charger to 24 V!</b></p>	See „Manual Battery Charger“
5		<ul style="list-style-type: none"> <li>Charge the Battery completely.</li> </ul>	See „Manual Battery Charger“

## 8 Troubleshooting

To avoid machine damage or life-threatening injuries while resolving faults with the lifting platform, the following points must be observed at all times:

- Only attempt to repair a malfunction if you are suitably qualified to perform such work.
- Protect the service lift from unintentional restart by disabling the compressed air supply.
- Secure the upper frame in the lifted position with a stand or a proper support.
- Also read the **chapter "General Safety Instructions"**.

### 8.1 Possible problems and their resolutions

Error	Error correction
Transmobil do not drive	<ul style="list-style-type: none"> <li>- Check the key switch on Transmobil.</li> <li>- Check Emergency-Stop switch on Transmobil.</li> <li>- Check the main switch on the remote control.</li> <li>- Check the state of charge of Transmobil battery and recharge batteries if necessary (see chapter "<b>Battery</b>").</li> <li>- Check the state of charge of the remote control battery and recharge batteries if necessary (see manual for <b>Gross Funk</b>).</li> <li>- Control the fuse of the receiver from remote control (see Check the fuse of the remote control).</li> </ul>



If, despite the above measures the Transmobil cannot approach the, **Customer Service** must be notified.

**Customer Service:** Herkules Hebetchnik GmbH  
 Miramstraße 68b  
 D – 34123 Kassel  
 Tel.: +49 (0)561 58907-0  
 Fax: +49 (0)561 58907-34  
 Email: info.de@hedson.com



When replacing defective parts, always only use original spare parts from the manufacturer.

## 8.2 Reading the Error Code

The multifunction display MDI on the Transmobil can currently pending diagnostic messages.

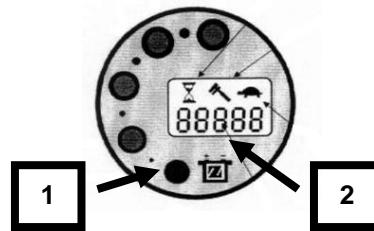

Image: multifunction display MDI on Transmobil

No.	Description	Information
1	Alarm-LED	Flashes when error
2	Display	Shows diagnostic message (A00 to A99)



To evaluate the error code, please contact customer service at the Hercules.

## 8.3 Check Radio Remote Control Fuse

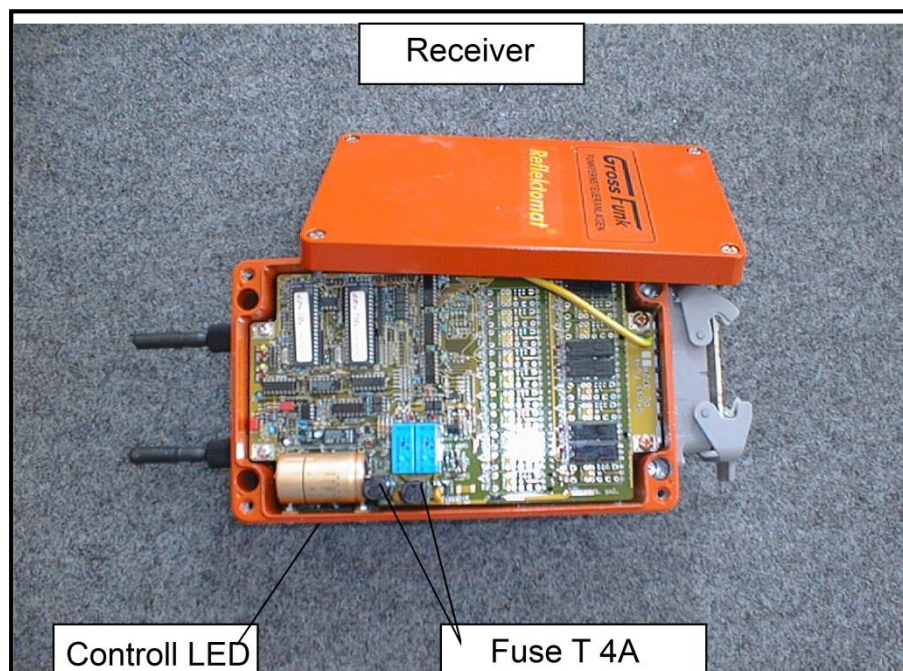

## 9 Maintenance Battery

### Maintenance

- Battery clean and dry.
- Check the fluid level regularly and adjust with distilled water. (At high water usage check water generator controller!)
- Do not use so-called enhancing agents!
- When acid density under 1.21 kg / l (1.18 in filling acid 1.23) recharge battery.



## 10 Safety Inspection

Safety inspection is required to guarantee the operational safety of the service lift.

### It should be performed:

Before starting up the lifting platform for the first time by the manufacturer.

The use of which can be found under the section "operation and safety inspection" (**Chapter operation and safety inspection**).

After the first commissioning, check at regular intervals in accordance to §10 (2) BetrSichV (German Plant Health and Safety Regulations)!

The use of which can be found under the section "regular safety check" (**Chapter regular safety check**).

Document the condition of the service lift in a separate copy and attach it to the operating instructions and inspection log.



**Regular safety checks must be performed by a suitably-trained person. It is advisable to also implement maintenance at the same time.**

## 10.1 Regular Safety Check

(In accordance with §10 ( 2 ) German Health and Safety regulations !)

Device type	
Serial number	

Inspection step	OK	Not OK	reexamination	Remark
Type plate				
Information Plates				
Operating instructions (short form)				
All load-bearing screws are firmly seated				
Steering drive function				
Wheel drive function				
Brake function				
Radio remote control function				
Electrical system and battery function				
Condition of load-bearing structure				
Function test with lifting platform and vehicle				
Steering drive function				

Inspection result	
	Start-up not permitted, verification required
	Start-up possible, faults to be rectified by: .....
	No fault, start-up possible immediately

Safety inspection performed on: .....

Name and address of qualified personnel .....

.....  
Signature of competent person

.....  
Signature of operator

### With the required rectification of faults

.....  
Signature of competent person

.....  
Signature of operator

## **11 Disassembly and Disposal**

### **11.1 Disassembly**

During disassembly the safety rules in the chapter "**General Safety Information**" must be observed.

### **11.2 Disposal**

Depollute the Transmobil to current environment and disposal guidelines.

## 12 Additional Information

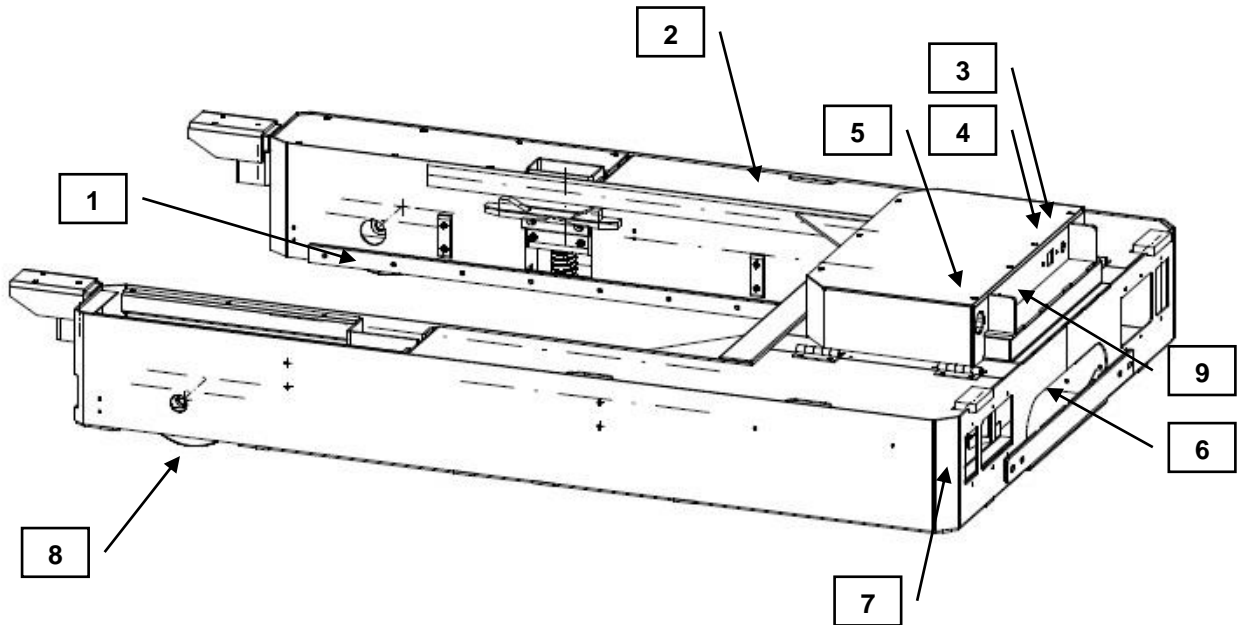

No.	HLT-03	Item number	quantity
1	PA 6 40x10x1396 mm	2 STAB 2090	2
2	Battery 12V/54Ah K5	810-506-1	4
3	Switch Modell KSO-SC	805-132	1
4	Emergency stop switch	800-507	1
5	Display MDI	810-512-3	1
6	Power engine	810-512	1
7	Connector 50mm <sup>2</sup>	805-129	1
8	Vulkollan-heavy-duty wheel	830-157	2
9	Flashing light "Hella"	805-123	3
-	Battery charger Transmobil	810-511	1
-	Radio remote control	810-546	1

Dimension Sheet HLT-03

