

## Operating manual and test record for elevating platform

Machine Type	Article. - No.	Serial- No.
Painter	Painter 01-07	

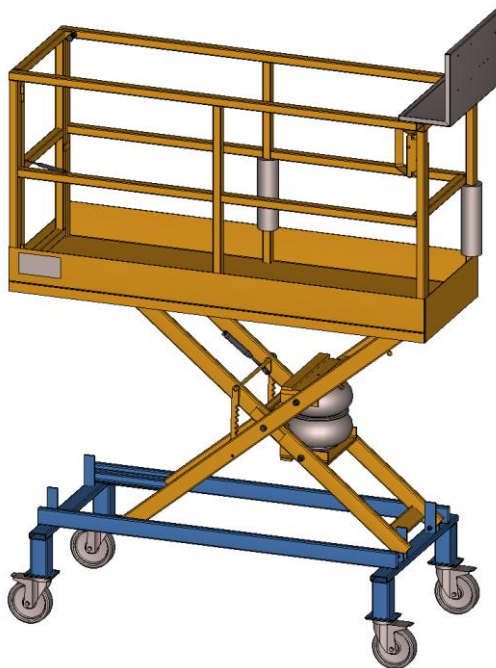

Herkules Hebetchnik GmbH  
Falderbaumstraße 34  
D-34123 Kassel  
Tel.: +49 (0) 561/58907-0  
Fax: +49 (0) 561/58907-34  
Email: [info@herkules.de](mailto:info@herkules.de)  
Internet: [www.herkules.de](http://www.herkules.de)

760-032\_Painter\_01-07\_2016.10\_2.2\_ENG

## **About**

Publisher:	Herkules Hebetchnik GmbH
Address:	Herkules Hebetchnik GmbH
Address of Service:	Falderbaumstraße 34, D - 34123 Kassel
Telephone:	+49 (0)561 58907-0
E-Mail :	info@herkules.de
Version:	2.2
Writer:	Herkules Hebettechnik GmbH

## TABLE OF CONTENTS

---

### Table of contents

1	Operation and Safety Inspection .....	5
2	General information .....	6
2.1	Hazard warnings .....	6
2.2	Limitation of liability .....	6
2.3	Copyright.....	7
2.4	Terms of guarantee .....	7
2.5	Customer service .....	7
3	Product description.....	8
3.1	Intended use .....	8
3.2	Assembly.....	9
3.3	Functional Description.....	10
3.4	Technical Information .....	11
3.5	Product designation.....	12
4	EC- Declaration of incorporation .....	13
5	General safety information .....	14
5.1	Operator's duty of care.....	14
5.2	Operator's duties .....	14
5.1	Basic safety measures .....	15
5.2	Requirements of operating personnel .....	16
6	Transport and preparation .....	17
6.1	Transport inspection.....	17
6.2	Disposal of the packaging materials.....	17
7	Installation and Assembly.....	18
7.1	Environmental conditions for assembly .....	18
8	Operation.....	19
8.1	Commissioning.....	21
8.2	Compressed air connection.....	21
9	Troubleshooting.....	22
9.1	Possible problems and their resolutions.....	22
10	Maintenance .....	23
10.1	Air bags characteristics and durability .....	24
10.2	Notice about filter regulator and air line.....	24
10.3	Notice about the sliding area of the scissors .....	24
11	Safety Inspection.....	25
11.1	Regular safety check.....	26

12	Additional information .....	27
12.1	Painter 01 .....	27
12.2	Painter 02 .....	32
12.3	Painter 03 .....	38
12.4	Painter 04 .....	39
12.5	Painter 05 .....	43
12.6	Painter 06 .....	44
12.7	Painter 07 .....	45

# 1 Operation and Safety Inspection

Carried out by the manufacturer to check the following details:

## Following plates present:

- Nameplate
- Operating instructions (abbreviated)
- Lifting capacity
- bar mains pressure
- Raise "up",- lower "down"
- Company logo

## Operation and safety checked:

- Safety valve set to 6.5 bar operating pressure**

## Inspected:

- Unloaded function test
- Safety catch function
- The control valve automatically goes into the 0 position
- No damage to the surface of the air bags
- Secure fit of all supporting screws
- Safeguard of the scissor pins
- Condition of the pneumatic lines (proper position and do not leak)
- Door lock function

Painter:  01    02    03    04    05    06    07

Serial No.: See cover sheet

Date: \_\_\_\_\_

Name: \_\_\_\_\_

Herkules Hebetchnik GmbH  
Falderbaumstraße 34  
D - 34123 Kassel  
Tel.: +49 (0) 561/58907-0  
Fax: +49 (0) 561/58907-34

## 2 General information

The operating instructions (and test log book) contain important information concerning the installation, and ensure safe, proper, and economical operation as well as preservation of operational safety. Observance of these operating instructions will help you to avoid danger, reduce repair costs and downtime as well as to increase the life of your service lift.

As evidence of regular **safety checks** this test log book contains a form. This should be used to provide documented details of tests. (It is advisable to make a copy of the form before starting to fill it out.)

### Installation and testing

Safety-related work and safety inspections may only be performed by suitably trained personnel. In this documentation, personnel are designated as expert and qualified persons.

## 2.1 Hazard warnings

To identify hazardous areas and important information, the following symbols with the described definitions are used. Please pay special attention to text sections marked with these symbols.



Signifies danger for life and limb, meaning improper execution of the process referred to by the symbol may be fatal!



Signifies a notification of a key function or an important notice!

## 2.2 Limitation of liability

All details and indications in this operating manual were compiled taking into account the applicable standards and regulations, and the latest technology as well as our many years of insight and experience. The manufacturer accepts no liability for any damage caused by:

- Failure to adhere to the operating manual
- Improper use
- The intervention of non-qualified staff
- Arbitrary alterations
- Neglecting maintenance

## 2.3 Copyright

These operating instructions are to be treated as confidential and are solely intended for personnel working with the machinery. Transfer of the operating manual to third parties without the written consent of the manufacturer is prohibited.



**Text, drawings, images and other illustrations are copyrighted and intellectual property rights apply.**

## 2.4 Terms of guarantee

The terms of guarantee are included as a separate document in the sales brochures.

## 2.5 Customer service

For technical information, please contact our customer service center as follows:

<b>Customer service:</b>	Herkules Hebetchnik GmbH Falderbaumstraße 34 D - 34123 Kassel Tel.: +49 (0)561 58907-70 Fax: +49 (0)561 58907-34 E-mail: <a href="mailto:info@herkules.de">info@herkules.de</a>
--------------------------	--

## 3 Product description

### 3.1 Intended use

The mobile elevating platforms Painter 01-07 are provided to lift people to an elevated position where they can operate from the raised platform. Only proceed when no person is on Stage (see chapter “**General Safety Information**”).

The allowable capacity of elevating platform, consisting of the maximum capacity - person and load - load (see Technical Data). The allowable capacity should not be exceeded.

Working under a lifted platform and during the lifting and lowering movement is not permitted.

The access platforms Painter 01-07 can be used in explosive areas and are subject to the Directive 2014/34/EU. Measures to protect against explosion hazards are required. See Chapter “**Basic safety measures**”.



#### The marking of the equipment Ex II 3G c IIA T6

The platform is part of the equipment group II: category 3; used in general industry in zone 2 for gases of explosion group IIA

c = constructional safety

T6 = 85 ° C surface temperature

Execution as a device for use in category 2G and 1G is available on request

The scope of intended use also includes the reading of the current operating manual as well as compliance with all the indications included in the same – particularly safety instructions.

The scope also extends to ensuring that all inspection and maintenance operations are implemented within the prescribed time periods.

In the event of any accident resulting in personal injury or damage to property resulting from improper use, the operator of the lifting system shall be responsible and not the manufacturer!

Any other or additional use of the elevating platform is considered to be improper.

For all persons and property and for damages to a raised load, resulting from improper use is the operator of the elevating platform responsible, not the manufacture!

For additional Information about the mobile elevating platform Painter 01-07 see Chapter “**Technical Data**”



### 3.2 Assembly

The construction of the Painter contains following main groups:

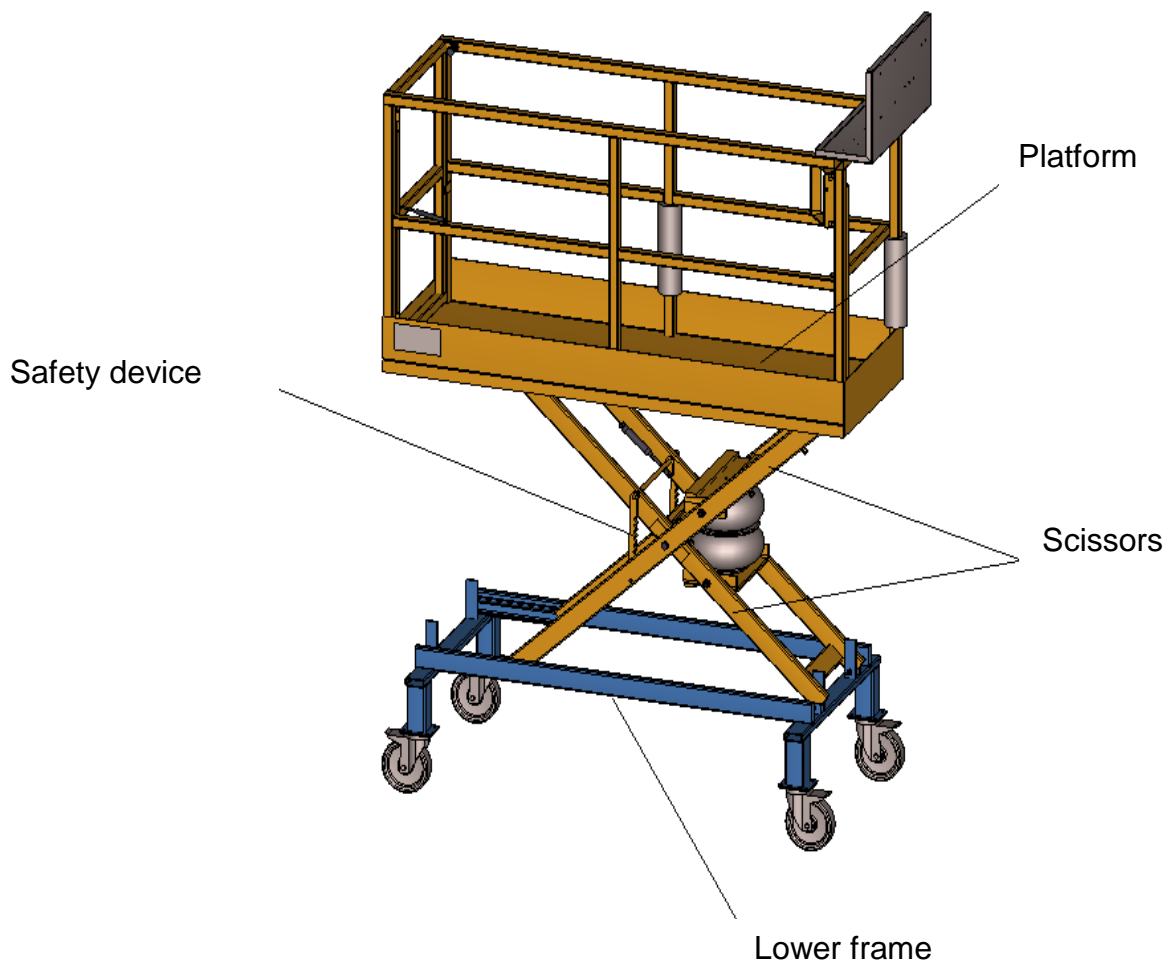

Diagram 1: Build Up Painter

### **3.3 Functional Description**

The new Painter 01-07 is designed to improve working conditions for surfaces processing of vehicle in paint shops.

The elevating platform can be raised and lowered fully adjustable. This enables to work ergonomically and to reach the requested surface for the best possible effect.

The Painter 01-07 is operated exclusively with compressed air. It can therefore be used in almost every work shop.

Due to the wheel system the platform can be positioned exactly. The brakes on the wheels prevent the platform from moving.

The Painter is operated from a user panel installed on the platform and can be raised and lowered infinitely variable.

All materials and tools required for work can be kept in the suspended holding fixtures and the operator can reach them easily.

### 3.4 Technical Information

	PAINTER 01	PAINTER 02	PAINTER 03
Max loading capacity	150 kg	150 kg	150 kg
Consisting of:			
Nominal load- person	80 kg (1 Person)	80 kg (1 Person)	80 kg (1 Person)
Nominal load- cargo	70 kg	70 kg	70 kg
Construction load (folded up)	1950 mm	1850 mm	1950 mm
Lifting capacity	1000 mm	2000 mm	800 mm
Platform length	2000 mm	3500 mm	1312,5 mm
Platform width	674 mm	674 mm	680 mm
Length of the base frame	2060 mm	3677 mm	1350 mm
Total Length	2153 mm	3717 mm	1545 mm
Width of the base frame	906 mm	1116 mm	906 mm
Pneumatic drive	1 Double airbag	3 Double airbag	1 Double airbag
Operating pressure for safety valve	6,5 bar	6,5 bar	6,5 bar
Pneumatic supply P <sub>max</sub>	8 bar (provided by customer)	8 bar (provided by customer)	8 bar (provided by customer)
Operating noise below	<70 dB(A)	<70 dB(A)	<70 dB(A)
<b>Safety devices</b>			
Safety valve	Yes	Yes	Yes
Emergency outlet	No	Yes	No
Safety catch (mech. / pneu.)	Yes (mech.)	Yes (pneu.)	Yes (mech.)

	PAINTER 04	PAINTER 05	PAINTER 06	PAINTER 07
max loading capacity	150 kg	250 kg	150 kg	250 kg
Consisting of:				
Nominal load- person	80 kg (1 Person)	160 kg (2 Pers.)	80 kg (1 Person)	160 kg (2 Pers.)
Nominal load- cargo	70 kg	90 kg	70 kg	90 kg
Construction load (folded up)	1960 mm	1850 mm	2350 mm	1850 mm
Lifting capacity	2000 mm	2000 mm	2000 mm	2000 mm
Platform length	2000 mm	3500 mm	3500 mm	3500 mm
Platform width	675 mm	674 mm	674 mm	674 mm
Length of the base frame	2153 mm	3677 mm	3677 mm	3677 mm
Total Length		4200 mm	4200 mm	4200 mm
Width of the base frame	1200 mm	1525 mm	1116/1616 mm	1620 mm
Pneumatic drive	3 Double airbag	3 Double airbag	3 Double airbag	3 Double airbag
Operating pressure for safety valve	6,5 bar	6,5 bar	6,5 bar	6,5 bar
Pneumatic supply P <sub>max</sub>	8 bar (provided by customer)	8 bar (provided by customer)	8 bar (provided by customer)	8 bar (provided by customer)
Operating noise below	<70 dB(A)	<70 dB(A)	<70 dB(A)	<70 dB(A)
<b>Safety devices</b>				
Safety valve	Yes	Yes	Yes	Yes
Emergency outlet	No	Yes	No	No
Safety catch (mech. / pneu.)	Yes (mech.)	Yes (pneu.)	Yes (mech.)	Yes (mech.)

**\*consider the difference between max. Loading capacity**

### 3.5 Product designation

The details of the mobile elevating platform are stated on the type shield on the machine frame as well as in the EC Declaration of conformity.

Details  
Nameplate

Article No.		Year of construction	
Machine type		Operating pressure	
Serial No.		Vers.	
Lifting capacity		Empty weight	

## 4 EC- Declaration of incorporation

As per appendix II B of EC- machine directive (2006/42/EG)

Manufacturer:	Herkules Hebetchnik GmbH Falderbaumstraße 34 D 34123 Kassel		
Publisher	Herkules Hebetchnik GmbH		
confirms that the below mentioned machine :	<b>Machinen-Type</b>  mobile elevating platform	<b>Art.-No.</b>  PAINTER-01 PAINTER-02 PAINTER-03 PAINTER-04 PAINTER-05 PAINTER-06 PAINTER-07	<b>Serial.-No.</b>  See cover sheet
Complies with the health and safety requirements of the following EC directives.	EC- machine directive 2006/42/EG directive 2014/34/EU		

Harmonized standards used:

EN 280	Mobile elevating platform
--------	---------------------------

Kassel, 12.10.2016

Ort, Datum

  
 Dirk Meinzer, **Managing Director**

## 5 General safety information

### 5.1 Operator's duty of care

The mobile elevating platform Painter 01-07 has been constructed and built in consideration of hazards analysis. Harmonized Norms as well as technical specifications have also been considered. The Painter 01-07 complies with the current technical standards and guarantees a maximum level of safety.

In the practice, the level of safety can only be achieved if all necessary measurements have been implemented. The lift owner/operator is responsible for these measurements.

**In particular, the operator has to ensure that:**

- the platform is used only for the intended purpose (see chapter entitled "**Product Description**").
- the platform only is operated in perfect and properly functioning condition, and that in particular the safety devices are regularly checked for correct function.
- Access to the danger area (area under platform and under the load) by individuals is forbidden. Operations in the danger area are prohibited. Maintenance operations are excluded, (see Chapter on "**Maintenance**").
- the operating instructions are complete and available in a legible condition where the platform is used.
- the platform is only used by individuals having read and understood the operating instructions.
- only sufficiently qualified and authorized staff is using, operating and repairing the platform.
- None of the safety and warning notices linked to the lifting platform are to be removed and must remain readable.
- Personnel are to be regularly instructed of all relevant information regarding work safety and environmental protection and familiar with the operating instructions and the safety notices therein.
- After completing work with the elevating Platform the platform must be in the lower end limit.

### 5.2 Operator's duties

The operating safety ordinances are intended for the operators of work equipment used in vulnerable areas.

The operator must take a risk assessment of the area where the work equipment will be used. The dangers that arise during the use of the work equipment related to the substances and working environment should be detected and taken into account.

The operator shall take the measures necessary and choose operating equipment suitable for the conditions prevailing at the workplace and assure the safety and health of employees.

For the execution of risk assessment and decision on suitable equipment, the operator must apply country-specific guidelines and standards.

## 5.1 Basic safety measures



When operating the mobile elevating platform the statutory accident prevention regulations in accordance with BGV A1 (General requirements) apply. Regulations BGR 500 (operators of work equipment) can be used for information purposes.



When moving the elevating platform it has to be in base position (it means completely lowered) and no person or cargo is allowed to be on it.



The operator is to monitor the mobile elevating Platform during lowering and lifting.



The mobile elevating Platform lift parts such as hose or air bags must be protected while working with high temperatures (welding, grinding, etc.) and from mechanical and chemical damage.

Compliance with the following points is particularly emphasized:

- The elevating platform Painter 01-07 is a mobile elevating platform for lifting and lowering individuals and cargo!
- While operating the mobile elevating platform, instructions in the operator's manual are to be complied with.
- The process of the mobile platform is (fully lowered) only in the normal position and allowed no person and payload.
- Only persons who are 18 years old or older and instructed in the use of mobile elevating platform are permitted to use it.
- The permissible loading capacity consisting of the rated load for persons plus the rated load for cargo must not be exceeded.
- Ensure that the elevating platform is used on a secure surface sufficiently far away from other objects, walls and ceilings! Maximal permitted gradient is 2,5% (1/40 i.e. 2,5 cm per 100 cm).
- When working on the platform the manual force should not amount to exceed 200N max.
- The elevating platform has to be under observation by the operator during the entire lifting or lowering procedure!
- It is forbidden for persons to stay under the load bearing mechanism or within the swinging range of the scissors!
- Only to be used indoors. It is not allowed to be located outdoors!
- If alterations are made on the construction or if the load-bearing parts have been repaired, the elevating platform must always be tested by an expert. Alterations and repair works have to be entered into the original form sheet.
- Never climb up onto the elevating platform. Such action is strictly forbidden.
- The work platform should not be used as a lift or crane.
- The platform can be made suitable for other -Area by an appropriate upgrade (e.g. wheels or ground strap).

## 5.2 Requirements of operating personnel

The platform must only be used by individuals who have been suitably trained, instructed and authorized. These persons must be familiar with the operating manual and proceed in accordance with the same. The respective authorizations of the operating personnel are to be clarified.

Moreover, for the following activities, specific qualifications are required:

Operation	Execution
Installation	Herkules service assemblyman / qualified person
Starting up	Herkules service assemblyman / qualified person
Briefing	Herkules service assemblyman / qualified person
Fault clearance	Herkules service assemblyman / qualified person
Servicing	Herkules service assemblyman / qualified person
Maintenance	Herkules service assemblyman / qualified person
Repairs	Herkules service assemblyman
Disassembly	Herkules service assemblyman / qualified person

Operating individuals in training should only operate the lifting platform when supervised by an experienced person. Evidence of completed and successful training should be confirmed in writing.

All control and safety installations must, generally speaking, only be operated by suitably trained persons.

All individuals engaging in activities involving the lifting platform must read the operating instructions and sign to confirm that they have understood them.



## 6 Transport and preparation

### 6.1 Transport inspection

Check the order upon receipt of delivery for damages caused during transport.  
If there is identifiable damage, proceed as follows:

- Leave the goods and packaging in an unchanged state. Do not attempt to use the product.
- Immediately contact Herkules customer service.

**Customer service:** Herkules Hebetchnik GmbH  
Falderbaumstraße 34  
D - 34123 Kassel  
Tel.: +49 (0)561 58907-70  
Fax: +49 (0)561 58907-34  
E-mail: info@herkules.de



**Do not send back damaged goods before receiving confirmation from the customer service center!**

### 6.2 Disposal of the packaging materials

The packaging material must be disposed of in accordance with the current environmental - and disposal guidelines.

## 7 Installation and Assembly

The following important safety instructions must be observed during the assembly of the service lift. Adhering to safety instructions helps to avoid life-threatening injuries, personal damages, as well as damage to machinery.

- The installation work must only be performed by suitably-trained persons and with compliance of the safety instructions during the process.
- Before commencing the installation work, the lifting platform must be investigated for damage in transit.
- Always ensure that only authorized persons enter the working space and that no other persons are exposed to any risk from the installation work.
- All machine connections (tubes) are laid out so that there is no risk of stumbling.
- Also read the Chapter "**General Safety Instructions**".

### 7.1 Environmental conditions for assembly

The mobile elevating platform is only suitable for use in dry, closed, indoor rooms.

Before installation, make sure there is enough distance to objects, walls and ceilings. It is important to ensure that minimum distances (according to national laws and workplace regulations) on the hall walls or other equipment, escape routes, etc. are in place to ensure safe working.

The floor surface must be even, the maximum permissible gradient is 2.5% (1/40 cm by 2.5 cm je 100) also has the load capacity of the floor may be designed to contribute to the maximum permissible weight of the platform. Choosing a suitable location for the operator of the platform itself is responsible.

The mobile elevating platform must only be used within a temperature range of 10°C to 50°C. During the selection of the assembly location bear in mind the measurements of the mobile elevating platform that are outlined in the chapter on "**Technical data**" as well as the chapter on "**Additional information**".

A compressed air supply R1/2" of 8 bar mains pressure must be available near the mobile elevating platform..



**Only use dehumidified, non-lubricated compressed air! A filter regulator must only be installed in the mains connection (air filter and water separator)!**

## 8 Operation

Locate the elevating platform to the desired place.



**When moving the Painter, it has to be completely lowered and no persons are allowed to be on it.**

Block the undercarriage with the brakes on the wheels. Check the braking effect!

Make sure that the platform is positioned sufficiently far away from objects, walls and ceilings! The floor surface must be even; the maximum permissible gradient is 2.5% (1/40 i.e. 2.5 cm per 100 cm). Check the evenness with cross spirit level fixed on the frame

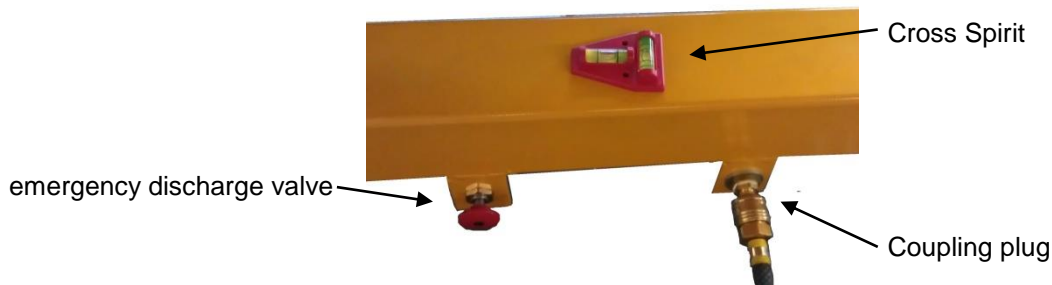

**Diagram 2:** *Cross spirit*

The platform side with the “half high” railing (depending on model) has to be installed beside a “natural security” (wall, vehicle etc.). It is not allowed to raise the platform without this “natural security”.

Connect the customer’s main air supply ( $P_{max} = 8$  bar provided by customer) with the coupling plug. The plug has to engage firmly.



**The Painter 01 – 07 has an emergency discharge valve. In an emergency or if the control valve fails, the platform can be lowered by a person standing alongside the platform. Push the emergency discharge valve until the platform reaches the base position.**

**To raise and lower the Painter proceed as follows:**

Step onto the Painter, or load the platform, and close the gate. Start the lifting operation only when the door is closed.



**When raising the platform the gate has to be closed and locked.**

Open the stopcock on the hand lever valve.

Push the lever switch to the top and hold it there until the elevating platform has reached its desired height or the maximum lift. Observe the procedure. Make sure that there is a clear view of the lift while it is lifting.

By releasing the lever switch the valve returns automatically to position “0” and the lifting process ends immediately.

The lifting process ends automatically when maximum lift is achieved.

**To lower the Painter proceed as follows:**

Check the danger area to ensure that no persons or objects are located in the working area of the elevating platform.

Push the lever switch to the bottom and hold it down until the elevating platform has reached desired height or is totally lowered. Observe the procedure. Make sure that there is a clear view of the platform while it is lowering.

By releasing the lever switch the valve returns automatically to position "0" and the lowering process ends immediately.

Before leaving close the pressure control stopcock on the hand lever valve.

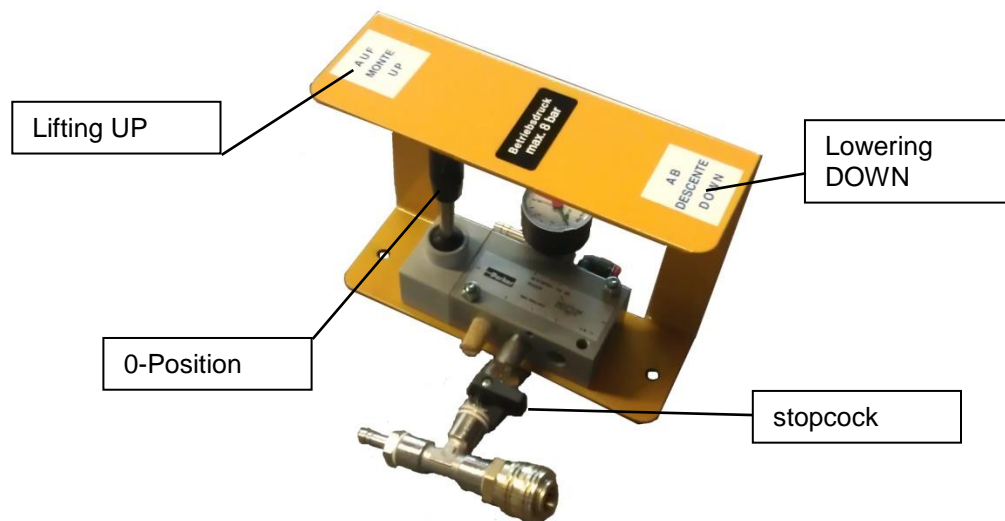

**Diagram 3:** Hand lever valve Painter 02

**Mechanical Safety catch**

- Painter 01
- Painter 03

When raising the platform to the maximum lifting height the safety device is completely swung out. When lowering the platform to its basic position the safety device is automatically swung in.



**If it is not possible to lower the Painter this could be due to an eventual leak in the air hose which leads to pressure on the safety device. In this case push the lever switch to the top again (lift) until it is no pressure on the safety device. Afterwards repeating the lowering procedure.**

The pneumatic safety device consists of a non-return valve located in the front of the airbags.



**Pay always attention to the safety instructions when using the Painter.**

**Pneumatic Safety catch**

- Painter 02
- Painter 04
- Painter 06
- Painter 07

---

## 8.1 Commissioning

Read the following functional checklist before using the service lift:

- Make sure that no persons or objects are present in the area of operation of the elevating platform.
- Secure the compressed air supply.
- Open the main tap on the operating control unit.
- Confirm that the operating control unit switch is in the lifting position - 'lift' until the service lift reaches the upper end limit.
- Confirm that the operating control unit switch is in the lowering position - 'lower' until the service lift reaches the lower end limit.
- Repeat lifting and lowering movements several times without load.

Observe the operating instructions for the respective work places on the service lift. Only the operating personnel may stand in the vicinity of the service lift while in use.

Also read the Chapter "**General Safety Instructions**".

## 8.2 Compressed air connection

Connect the customer's main air supply ( $P_{max} = 8$  bar provided by customer) with the coupling plug. The plug has to engage firmly.



**Only use dehumidified, non-lubricated compressed air! The main air supply has to be connected before using the Painter and disconnected when leaving the platform.**

**A filter regulator must only be installed in the mains connection (air filter and water separator)!**

## 9 Troubleshooting

To avoid machine damage or life-threatening injuries while resolving faults with the platform, the following points must be observed at all times:

- Only attempt to repair a malfunction if you are suitably qualified to perform such work.
- Protect the the mobile elevating platform from unintentional restart by disabling the compressed air supply.
- Secure the upper frame in the lifted position with a stand or a proper support.
- Also read the chapter "**General Safety Instructions**".

### 9.1 Possible problems and their resolutions

Malfunction	Source of fault	Rectification of errors
Malfunction while lifting	Pressure gauge of the maintenance unit without bar mains pressure.	Make sure there is a mains pressure of $P_{max} = 8$ bar. Open the shut-off valve.
	Hose lines squashed, bent, or damaged.	Check the hose lines and if necessary replace them with new ones.
	Gauge pressure 1 bar above allowable pressure of the safety valve	Check the safety valve for contamination and replace if necessary.
Malfunction while lowering	The mobile elevating platform is resting on top of an obstacle	Raise the platform, remove the obstacle, and then continue lowering.
	Safety catch engaged	For bar mains pressure $P_{max} = 8$ bar make sure the gear lever is switched to "Lift" until the safety catch is free. Afterwards repeat the lowering movement.



**If, despite the above measures, the platform cannot be lifted or lowered, the customer service department must be notified.**

**Customer service:**

Herkules Hebetchnik GmbH  
 Falderbaumstraße 34  
 D - 34123 Kassel  
 Tel.: +49 (0)561 58907-70  
 Fax: +49 (0)561 58907-34  
 E-mail: info@herkules.de



**When replacing defective parts, always only use original spare parts from the manufacturer.**

## 10 Maintenance

Maintenance work should be carried out at the specified maintenance intervals and only by qualified persons.

Neither water nor flammable liquids may be used during the cleaning process.

To ensure durability and continuous operation of the the mobile elevating platform, the following points should be observed:



- Only spare parts from the original manufacturer and suitable tools may be used.
- Regular maintenance intervals must be observed.
- For all maintenance work not outlined or explained in this instruction manual, please contact your supplier or customer service of the manufacturer.

Only perform maintenance when the platform achieves a max. (unloaded), the platform is braced with service supports, and the compressed air supply is disabled!

Maintenance intervals	Points to follow	Comments
Monthly	<p>All moveable parts such as pivot bolts, sliding pads, and sliding surfaces should be check for wear and tear, cleaned, and lubricated.</p> <p>Check air bags and air tubes for any damages. Visually inspect and check for leaks. Examine the surface of the air bags for impurities, then clean, and maintain.</p> <p>Inspect valves for functionality and check for leaks.</p> <p>Inspect the maintenance unit (filter regulator, provided by the customer), and consult the product manufacturer's instructions.</p>	Only use lubricants that contain no adhesive-repelling substances in the area to be lubricated.
Yearly	Regular safety check (In accordance with §10 ( 2 ) German Plant Health and Safety regulations)	For test protocol see Chapter “ <b>Regular safety check</b> ”.
Replace the safety valve	After every 2 years of operation.	
Every 6 years of operation	Replace the complete air hoses.	

## **10.1 Air bags characteristics and durability**

The air bags are a flexible element developed and designed specifically for use in elevating platforms. The rubber covering reduces the aging process and should be especially carefully checked.

Tips for a long operating life:

- Use dry as well as non-lubricated compressed air.
- Protect from UV radiation (i.e. through welding or the use of a UV dryer).
- Avoid the use of chemical agents.
- Protect the unit from damage (grooving, etc.).
- Adhere to maintenance and care instructions (see Chapter “**Maintenance**”).

Damaged air bags must be replaced. Only original parts from the manufacturer are permitted to be used.

## **10.2 Notice about filter regulator and air line**

The filter regulator is not included in the scope of delivery of the elevating platform. A filter regulator must be installed in the mains connection (provided by the customer). Only dehumidified, non-lubricated compressed air should be used. Follow maintenance and cleaning of the filter regulator, consult the information and instructions of the filter regulator manufacturer.

## **10.3 Notice about the sliding area of the scissors**

Due to the design principles of the sliding surfaces of the scissors, great force is exerted. This force can lead to scoring on the sliding surfaces. However, the function of the elevating platform will not be compromised. The maintenance intervals and instructions outlined in the Chapter “**Maintenance**” are to be observed.



# 11 Safety Inspection

Safety inspection is required to guarantee the operational safety of the elevating platform.

### It should be performed:

For the first time by the manufacturer before starting up the lifting platform.

The use of which can be found under the section "operation and safety inspection"(Chapter "**Operation and safety inspection**").

After the first commissioning, check at regular intervals in accordance to §10 (2) BetrSichV (German Plant Health and Safety Regulations)!

The use of which can be found under the section "regular safety check"(Chapter "**Regular safety check**"). Document the condition of the elevating platform in a separate copy and attach it to the operating instructions and inspection log.



**Regular safety checks must be performed by a suitably-trained person. It is advisable to also implement maintenance at the same time.**



## 12 Additional information

### 12.1 Painter 01

Dimension sheet

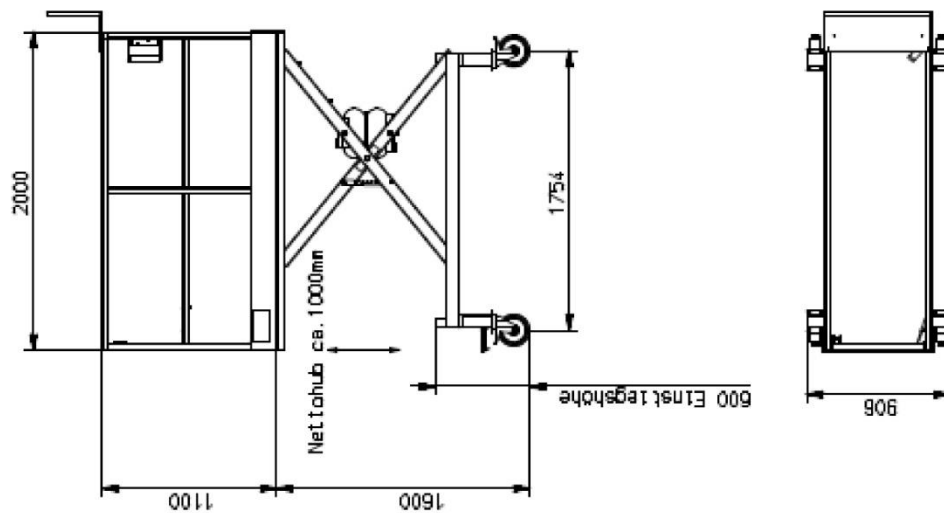
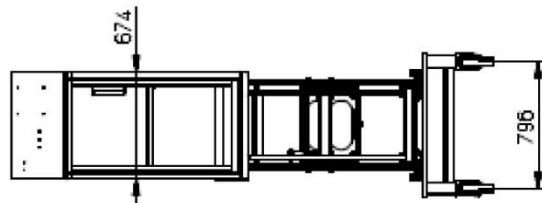

Pneumatic plan

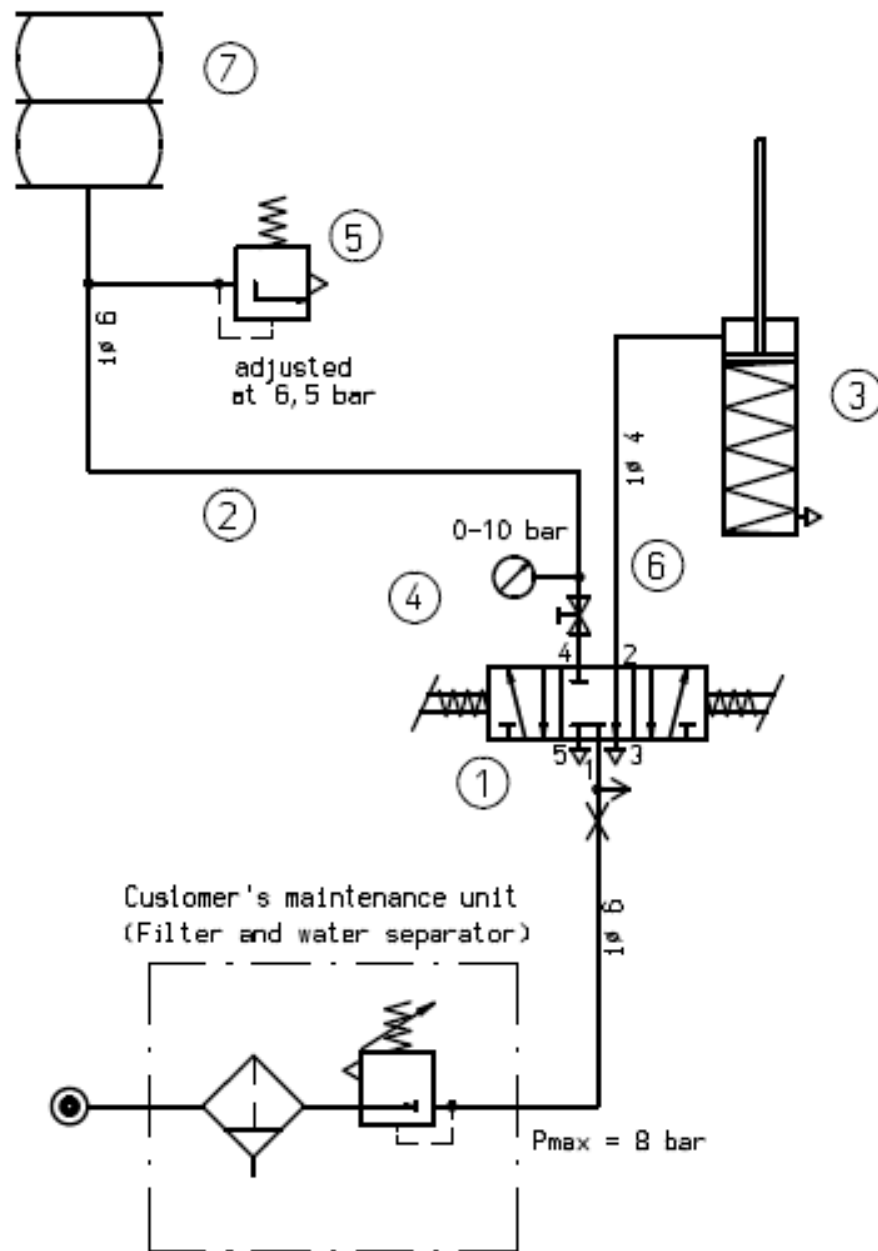

Pos.	Pieces	Art.-No	Description
1	1	PNT-01-028-3	Complete manual lever valve.
2	1	PNT-01-029-3	Complete Pneumatic Cylinder
3	1	800-220	Airbag
4	1	810-217	O-Ring
5	2	810-112	Sealing ring
6	1	700-174	Safety valve
7	1	730-118	Tail end
8	2	720-119	Hose clamp
9	1	720-106	Hose
10	1	720-103	PA-Hose

Hand lever valve

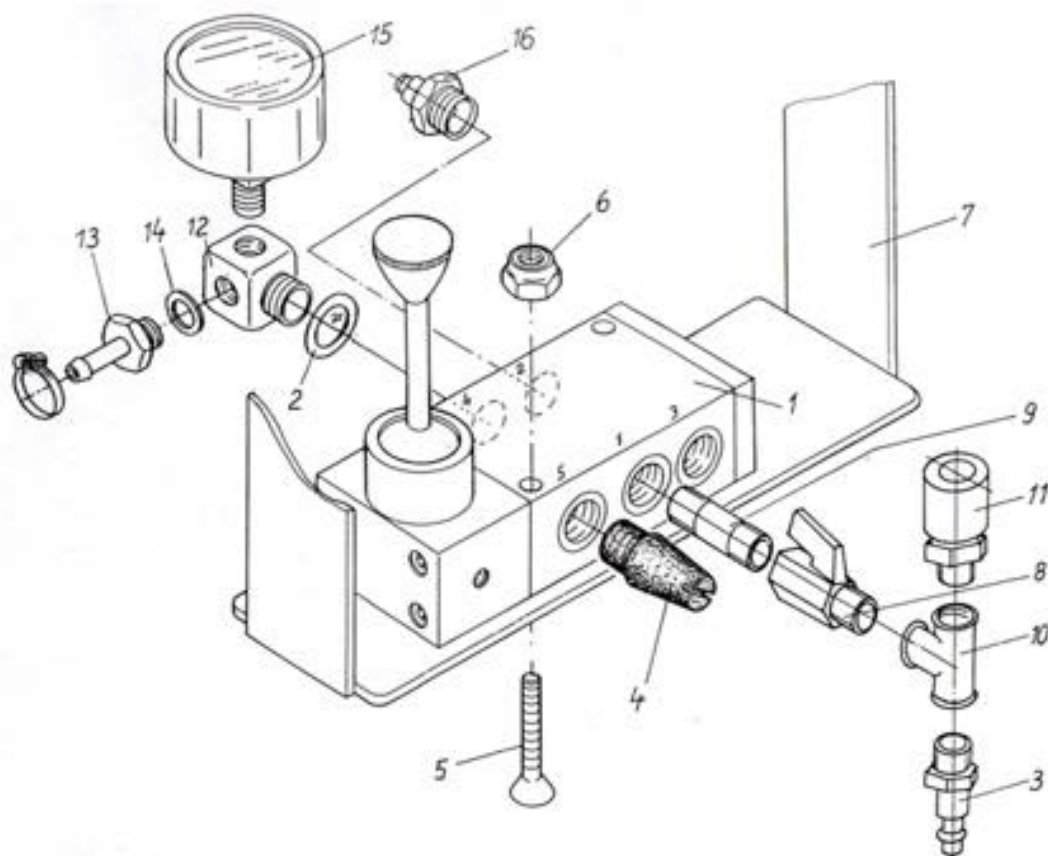

Pos.	Pieces	Art.-No	Description
1	1	300-063	Manual lever valve 5/3-way
2	6	810-112	Sealing ring
3	1	730-128	Coupling plug
4	1	810-118	Silencer
5	2	510-121	Cross recess screw
6	2	600-106	Hexagon nut
7	1	RS 1000-03-005-3	Protection frame
8	1	760-107	Mini ball tap
9	1	730-237	Double nipple
10	1	730-115	T-Piece
11	1	730-228	Coupling box
12	1	730-106	Angle distributor piece
13	1	730-117	Tail end
14	1	810-113	Sealing ring
15	1	735-103	Pressure gauge
16	1	730-103	Plug connection, straight
17	2	500-050	Hexagon screw

Assembly drawing

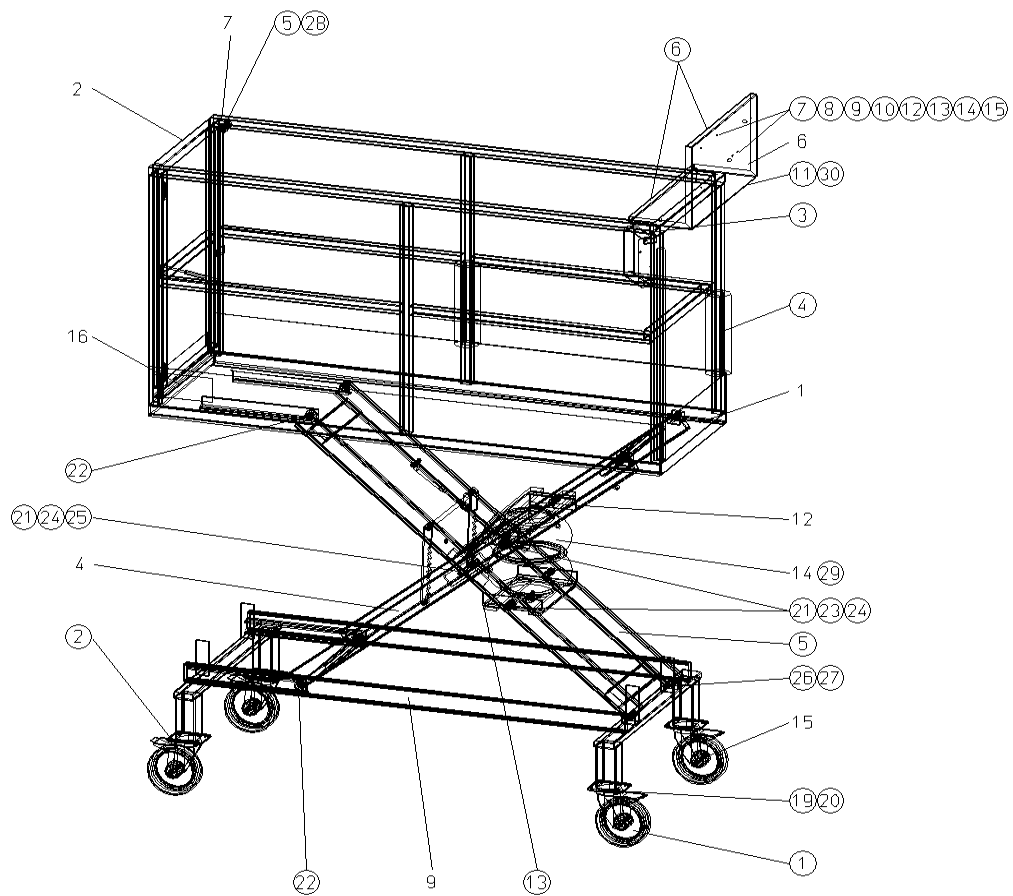

Pos.	Pieces	Art.-No	Description
1	1	PNT-01-004-1	Top frame
2	1	PNT-01-019-3	Gate
3	1	PNT-01-032-4	Raised pattern plate
4	1	PNT-01-015-3	Outside scissors
5	1	PNT-01-010-3	Inside scissors
6	1	PNT-01-023-3	Storage place
7	1	PNT-01-020-4	Complete locking device
9	1	PNT-01-009-2	Lower frame
12	1	HLM865-007-3	Airbag rocker, above
13	1	HLM865-008-3	Airbag rocker, below
14	1	PNT-01-027-4	Complete Pneumatic
15	1	PNT-01-026-4	Complete Standard parts
16	1	PNT-01-025-4	Stickers/Label
(1)	2	830-145	Wheel
(2)	10	850-419	Sliders
(3)	8	850-420	Sliders
(4)	1	810-230	SH-Optiflex Insulating hose
(5)	1	810-184	Ball button
(6)	1	810-201	Edge protection profile
(7)	4	HLA290-00-001-4	Hook
(8)	3	560-004	Screw hook, straight
(9)	2	PNT-01-024-4	Hook
(10)	1	730-350	transparent hose

Pos.	Pieces	Art.-No	Description
(11)	2	500-236	Drilling screw
(12)	9	600-230	Hexagon nut
(13)	15	600-106	Hexagon nut
(14)	4	500-050	Hexagon screw
(15)	2	650-116	Washer
(16)	1	500-100	Hexagon screw
(17)	1	600-110	Hexagon nut
(18)	4	810-109	Cable clip
(19)	12	500-028	Hexagon screw
(20)	12	600-110	Hexagon nut
(21)	16	650-117	Plate
(22)	4	693-103	Guide roller
(23)	4	500-010-1	Hexagon screw
(24)	6	600-120	Hexagon nut
(25)	2	500-158	Hexagon screw
(26)	4	600-114	Hexagon nut
(27)	4	500-139	Hexagon screw
(28)	1	500-021	Hexagon screw
(29)	4	510-079	Flat-head screw
(30)	1	900-C202	Handle
(31)	2	500-050	Hexagon screw

## 12.2 Painter 02

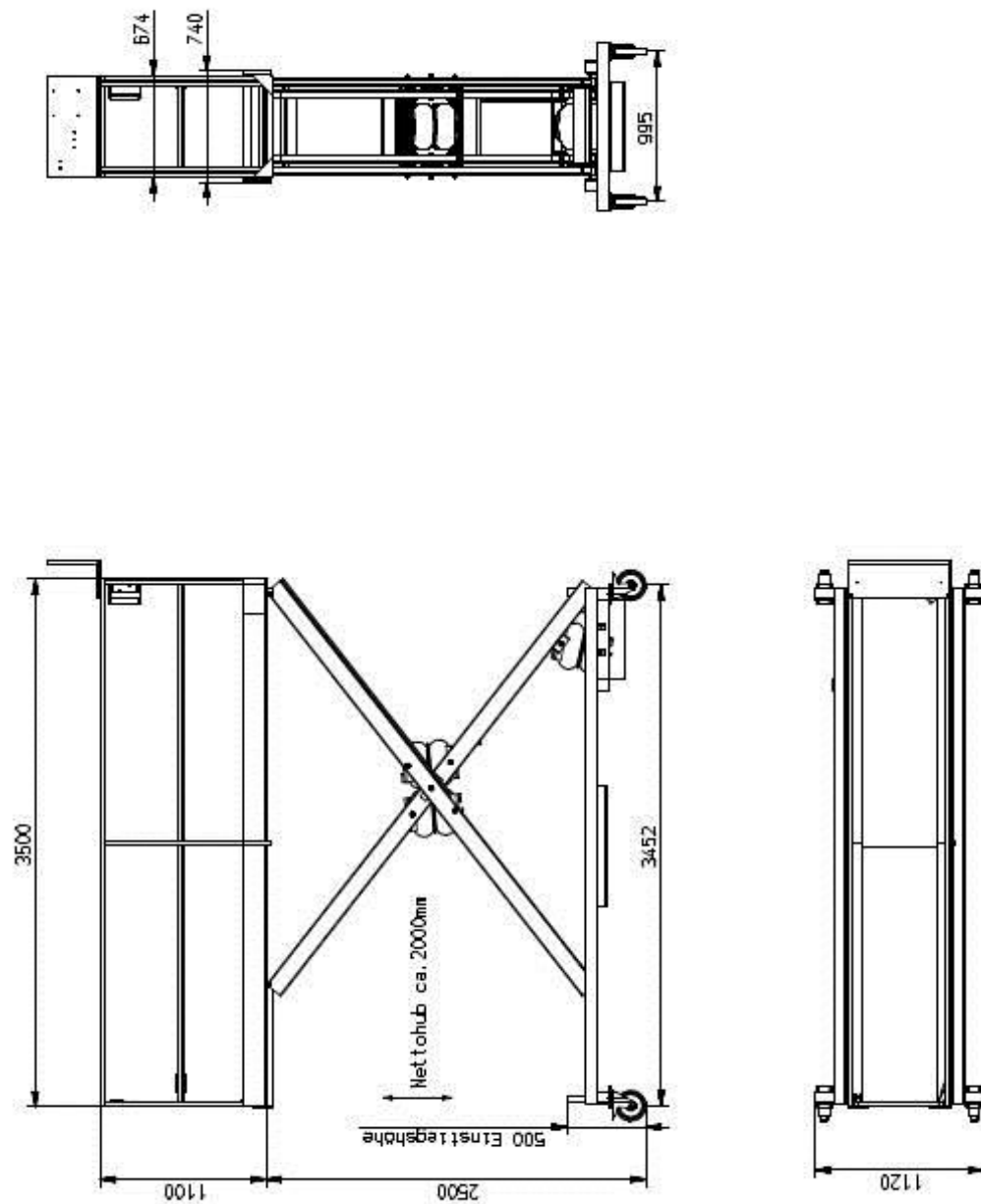



Pneumatic plan

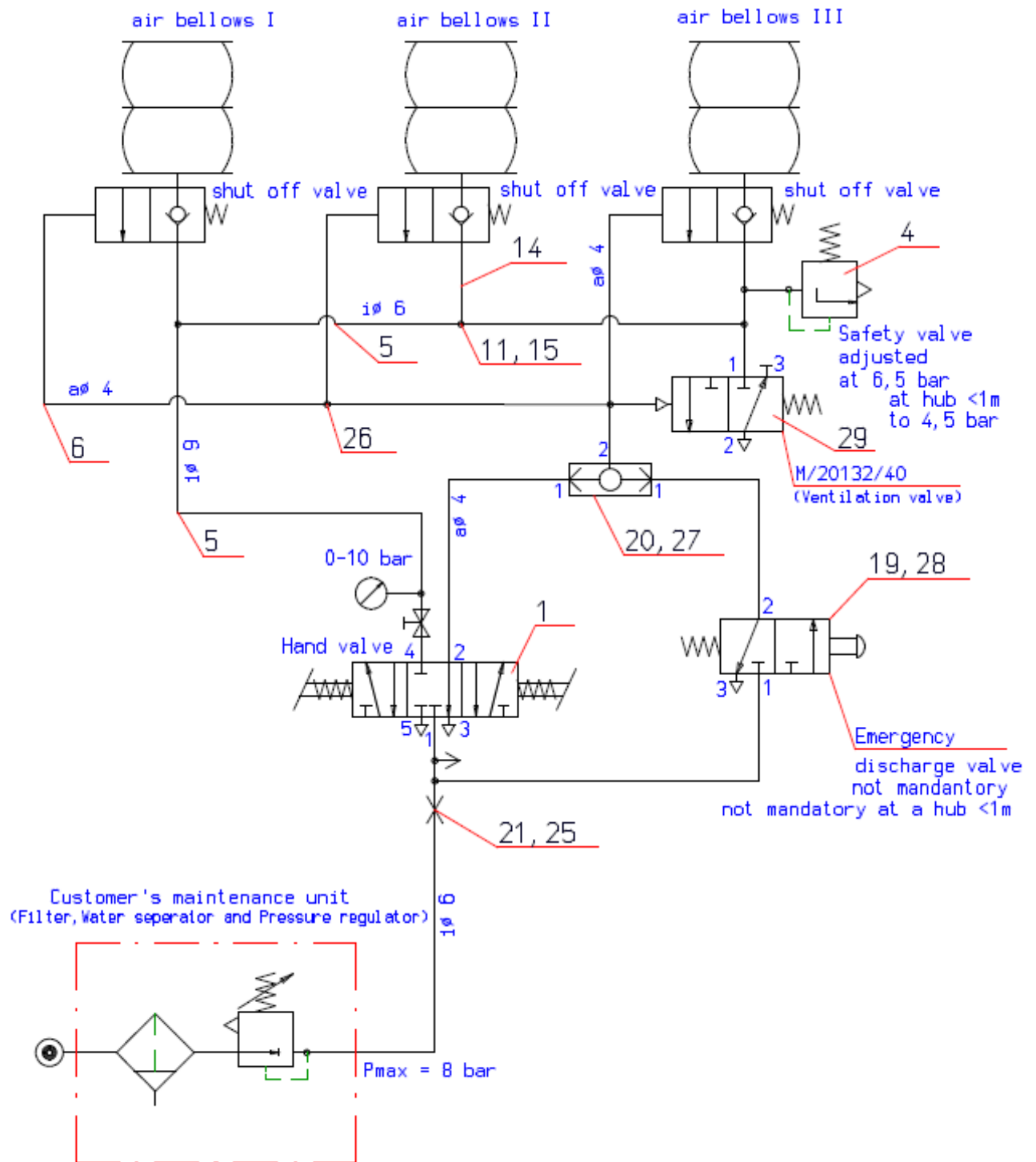

Pos.	Pieces	Art.-No	Description
1	1	PNT-02-3LB-051-3	Hand lever valve, complete
2	3	800-220	Airbag
3	3	810-217	O-ring
4	1	700-174	Safety valve
5	1	720-106	Hose
6	1	720-103	PA-Hose
7	12	720-119	Hose clamp
8	1	730-356	Sleeve
9	2	810-112	Sealing ring
10	8	810-113	Sealing ring
11	2	730-262	T-piece
12	1	730-020	T-Screw connection
13	3	730-376	Angle screw connection
14	3	730-464	Connection piece
15	5	730-465	Hose connection
16	3	700-176	Non-return valve
17	1	730-176	Double nipple
18	2	730-117	Tail end
19	1	730-152	Blind plug
20	3	730-103	Plug connection, straight
21	1	730-128	Coupling plug
22	2	730-115	T-Piece
23	1	730-127	Double nipple
24	5	730-118	Tail end
25	1	730-229	Bulkhead fitting
26	2	730-260	T-Piece
27	1	700-307	Shuttle valve
28	1	700-189	3/2-way valve
29	1	PNT-02-3LB-054-4	Ventilation valve

Hand lever valve (PNT-02-3BL-051-3)

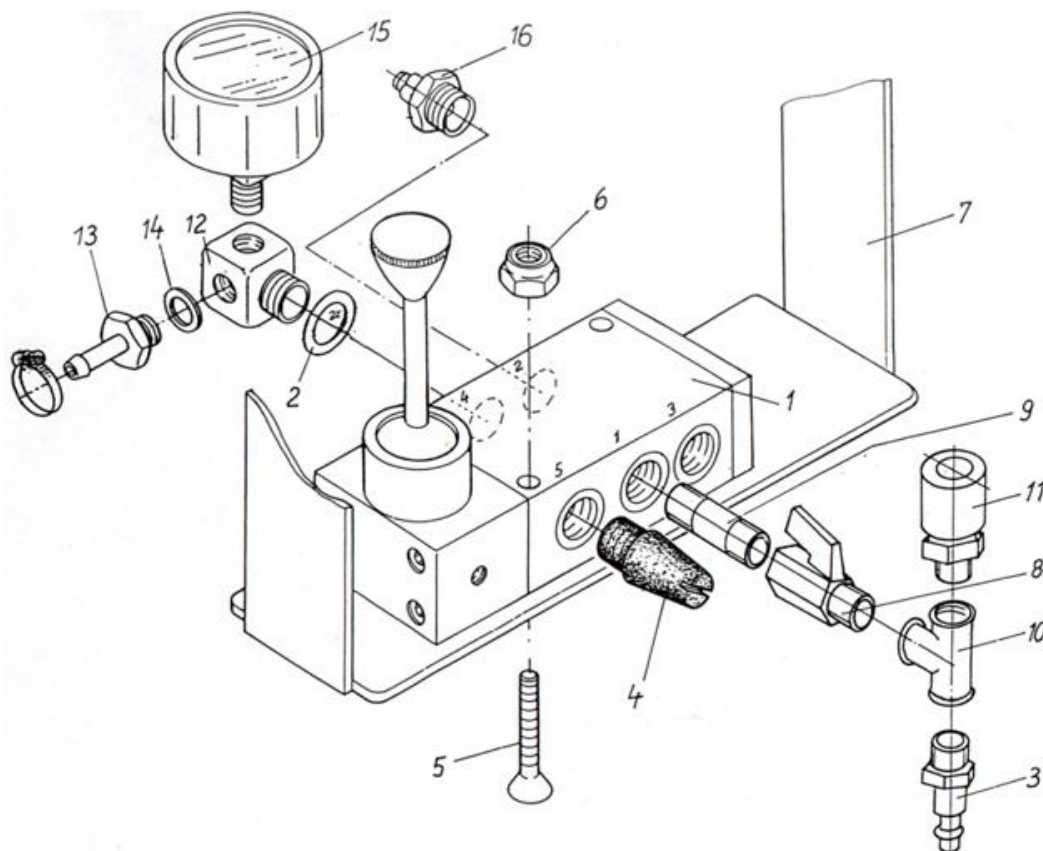

Pos.	Pieces	Art.-No.	Description
1	1	300-063	Hand lever valve 5/3-way
2	6	810-112	Sealing ring
3	1	730-118	Tail end
4	1	810-118	Silencer
5	2	510-121	Cross recess screw
6	2	600-106	Hexagon nut
7	1	RS 1000-03-005-3	Protection frame
8	1	760-107	Mini ball tap
9	1	730-237	Double nipple
10	1	730-115	T-Piece
11	1	730-228	Connection box
12	1	730-106	Angle distributor box
13	1	730-117	Tail end
14	1	810-113	Sealing ring
15	1	735-103	Pressure gauge
16	1	730-103	Plug connection, straight
17	2	500-050	Hexagon screw
18	2	600-106	Hexagon nut

Assembly Drawing

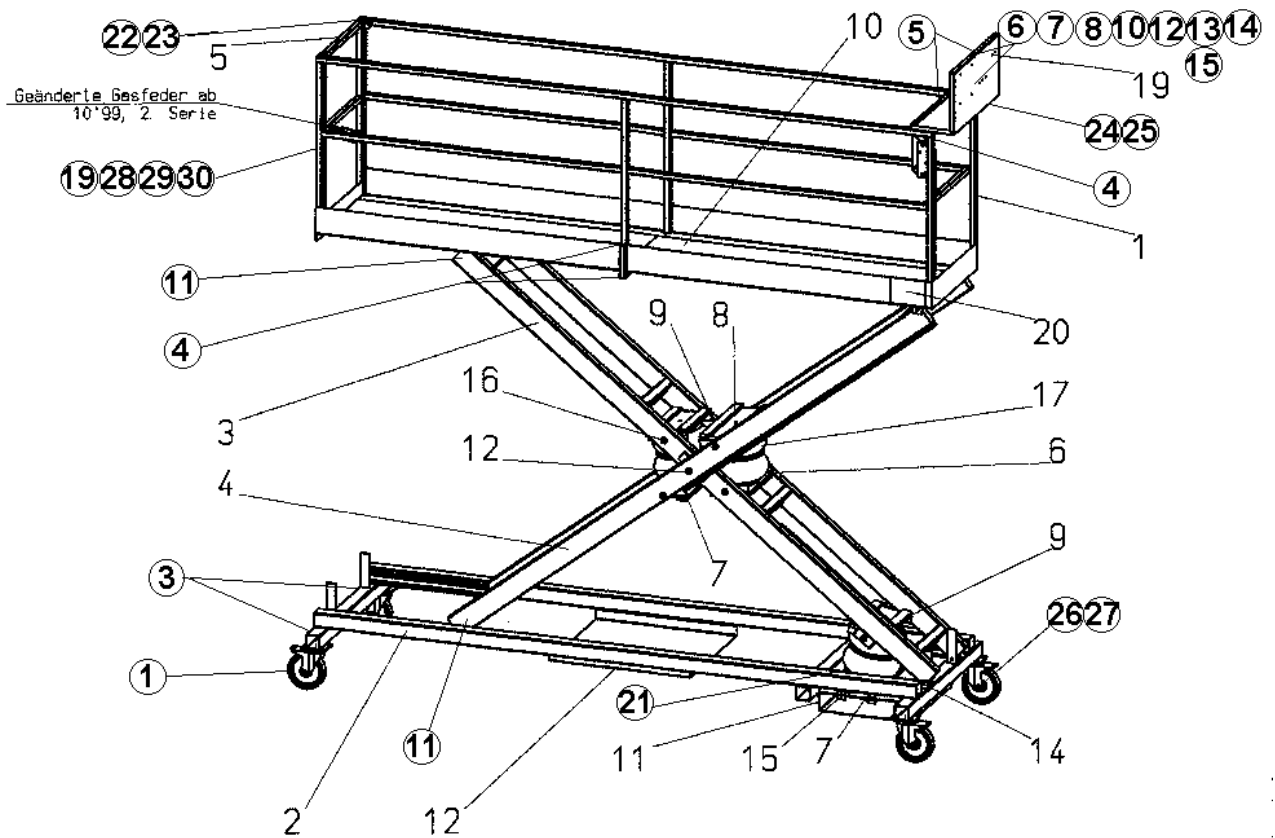

Pos.	Pieces	Art.-No.	Description
1	1	PNT-02-3LB-004-1	Top framer
2	1	PNT-02-3LB-014-1	Lower frame
3	1	PNT-02-3LB-018-3	Inside scissors
4	1	PNT-02-3LB-024-3	Outside scissors
5	1	PNT-02-3LB-028-3	gate
6	1	PNT-02-3LB-031-3	Airbag rocker I
7	2	PNT-02-3LB-033-3	Airbag rocker II
8	1	PNT-02-3LB-035-3	Airbag rocker e III
9	2	PNT-02-3LB-037-3	Airbag rocker IV
10	2	PNT-02-3LB-041-4	Raised pattern plate , storage place
11	1	PNT-02-3LB-042-3	Cover plate I
12	1	PNT-02-3LB-043-3	Cover plate II
13	2	PNT-02-3LB-044-4	Middle bolt
14	4	PNT-02-3LB-045-4	Solid bearing bolt
15	2	PNT-02-3LB-046-4	LBW-bolt I
16	10	PNT-02-3LB-047-4	LBW-bolt II
17	1	PNT-02-3LB-050-4	Pneumatic, complete
18	1	PNT-02-3LB-052-4	Standard parts, complete
19	1	PNT-01-023-3	Storage place
20	1	PNT-02-3LB-053-4	Sticker/Label

Pos.	Pieces	Art.-No.	Description
(1)	4	830-144	Wheel
(3)	10	850-420	Sliders
(4)	10	850-418	Sliders
(5)	1	810-201	Edge protection profile
(6)	4	HLA 290-00-001-4	Hook
(7)	3	560-004	Straight screw hook
(8)	2	PNT-01-024-4	Hook
(10)	1	730-350	Transparent hose
(11)	4	693-103	Guiding roller
(12)	9	600-230	Hexagon nut
(13)	15	600-106	Hexagon nut
(14)	4	500-188	Hexagon screw
(15)	2	650-116	Washer
(19)	2	730-383	Gas pressure spring
(21)	1	730-384	Cross spirit lever
(22)	1	690-129	Ratchet bolt
(23)	1	600-145	Hexagon nut
(24)	1	900-C202	Handle
(25)	2	500-236	Drilling screw
(26)	16	500-100	Hexagon screw
(27)	16	600-110	Hexagon nut
(28)	2	500-011	Hexagon screw
(29)	2	600-100	Hexagon nut
(30)	12	650-112	Washer

## 12.3 Painter 03

### Dimension sheet

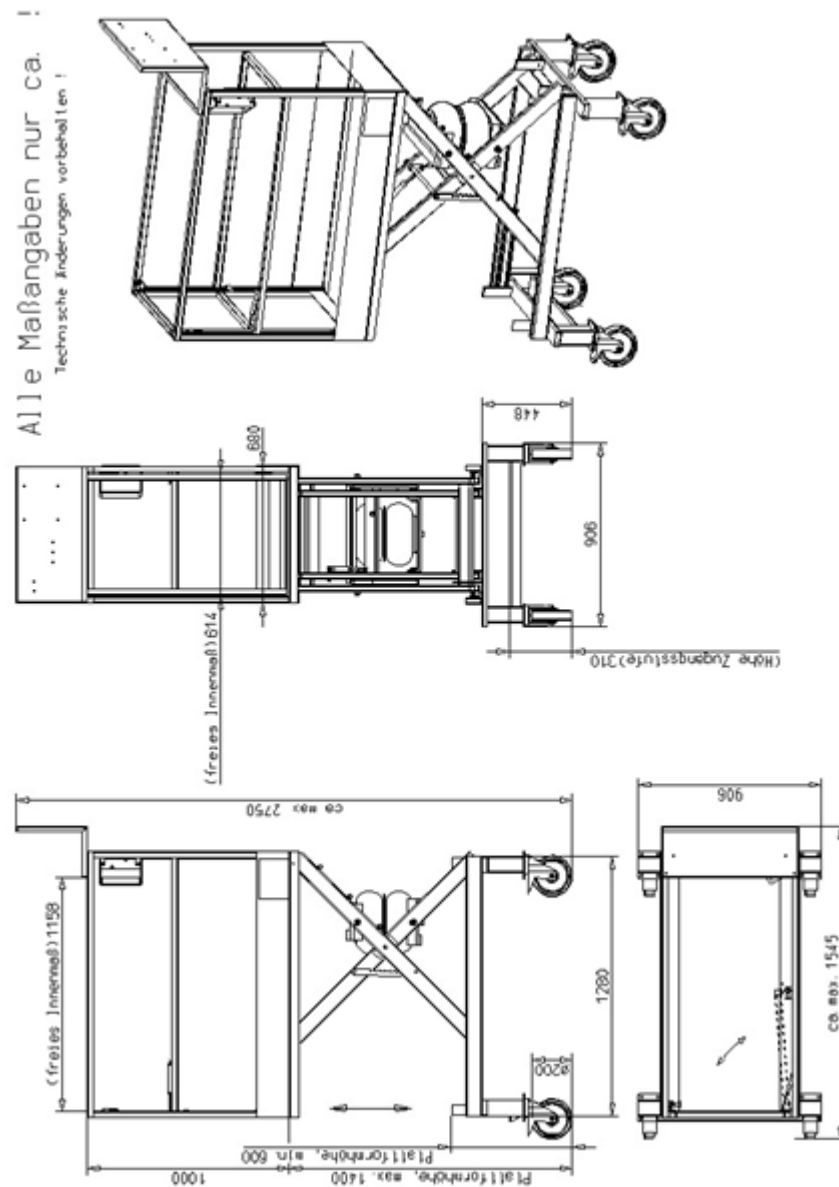

#### Pneumatic drawing

See Page 28: Pneumatic drawing Painter 01.

#### Hand lever valve

See Page 29: Hand lever valve Painter 01.

#### Composition

See Page 30: Composition Painter 01.

## 12.4 Painter 04

### Dimension sheet

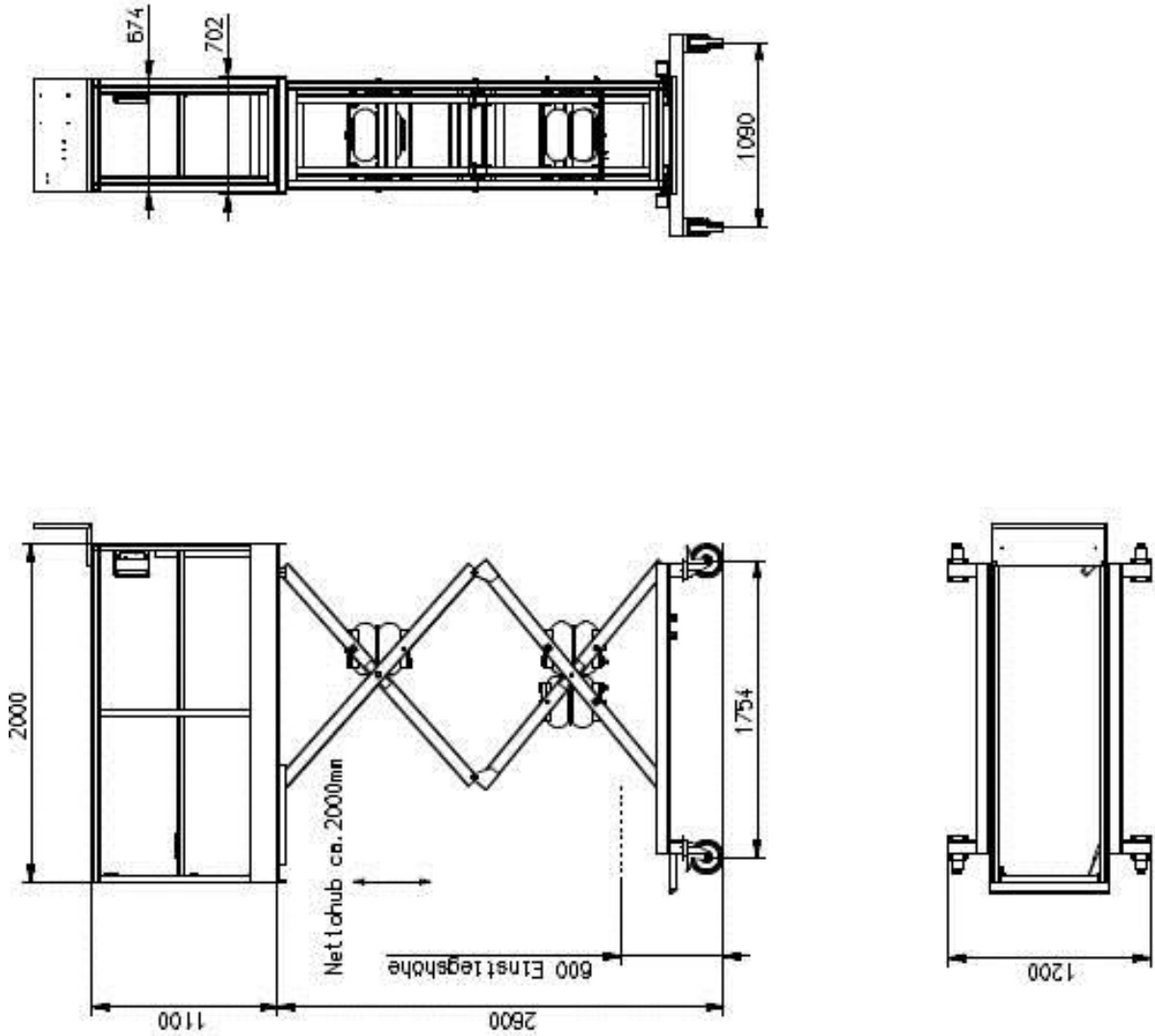

Pneumatic plan

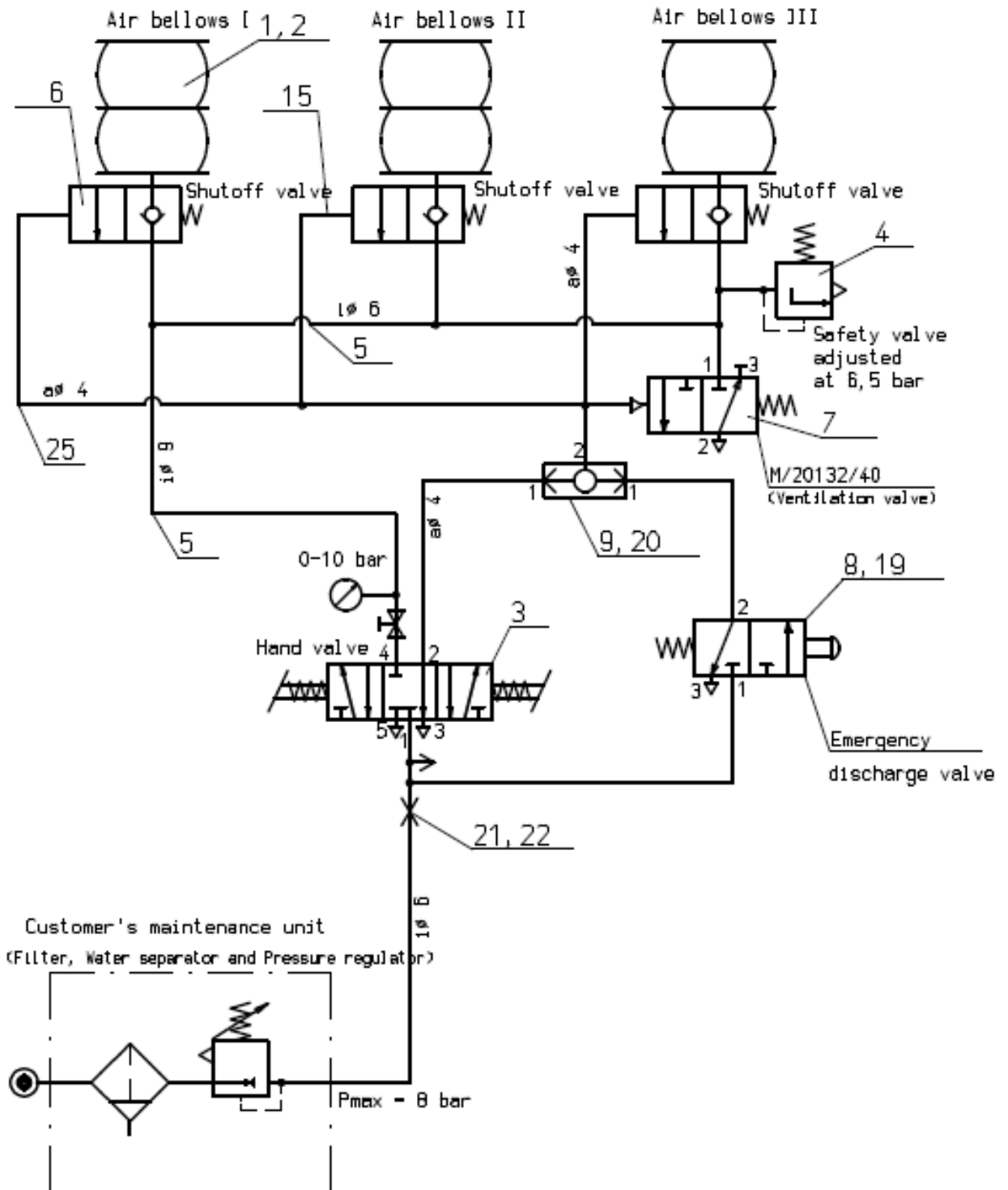



**Pneumatic Spar parts PNT 04**

Pos.	Pieces	Art.-No.	Description
1	3	800-220	Airbag
2	3	810-217	O-Ring
3	1	PNT-02-3LB-051-3	Hand lever valve, complete
4	1	700-174	Safety valve
5		720-106	Hose
6	3	700-179	Non-return valve
7	1	720-122	Ventilation valve
8	1	700-189	3/2 way valve
9	1	700-304	Shuttle valve
10	2	730-262	T-Piece
11	2	730-260	T-Piece
12	6	720-119	Hose clamp
13	1	730-356	Sleeve
14	1	730-020	T-Piece
15	1	730-376	Angel screw connection
16	1	730-290	Plug connection
17	1	730-176	Double nipple
18	1	730-117	Tail end
19	1	730-152	Blind plug
20	1	730-103	Plug connection
21	1	730-229	Bulkhead fitting
22	1	730-128	Coupling plug
23	4	730-118	Tail end
24	2	730-127	Double nipple
25	2	720-103	PA-Plug hose

**Hand lever valve**

See Page 29: Hand lever valve Painter 01.

Assembly Drawing PNT 04

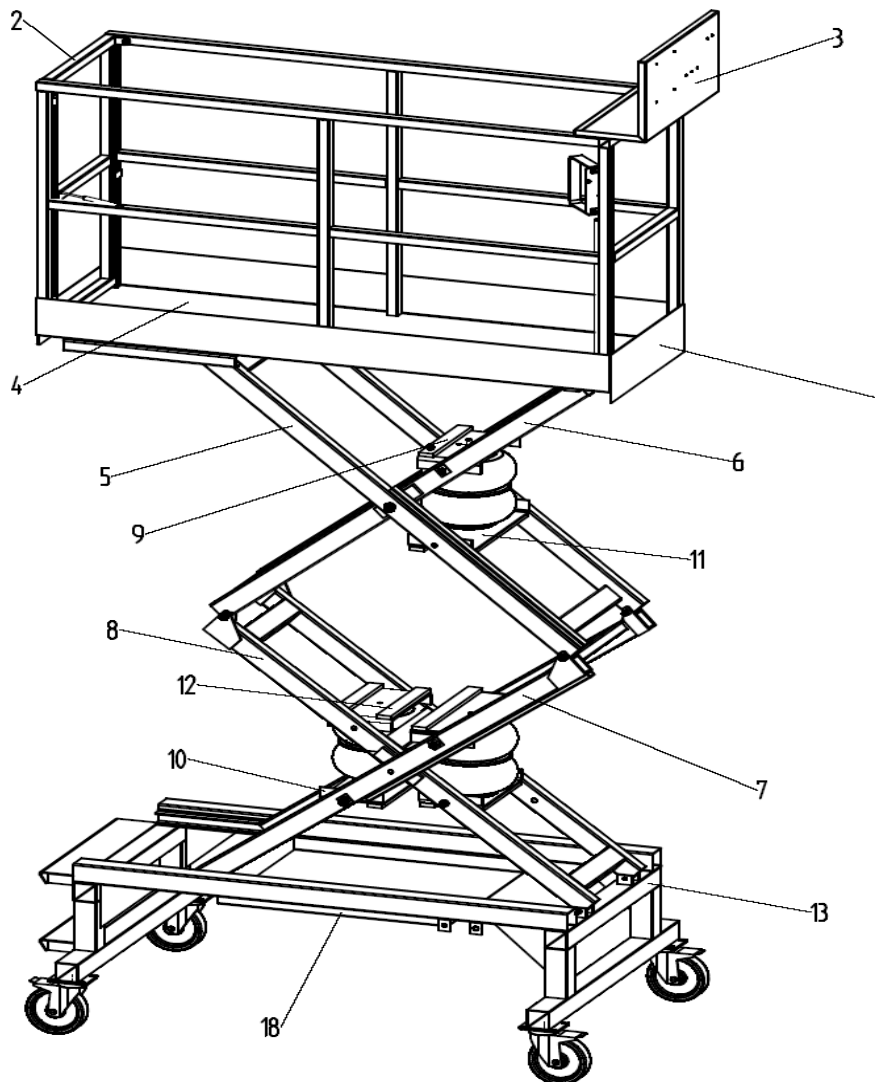

Pos.	Pieces	Art.-No.	Description
1	1	PNT-04-032-3	Top frame
2	1	PNT-01-019-3	Gate
3	1	PNT-01-023-3	Storage place
4	1	PNT-01-032-4	Step plate
5	1	PNT-04-017-3	Outside scissors on top
6	1	PNT-04-018-3	Inside scissors on top
7	1	PNT-04-033-3	Outside scissors below
8	1	PNT-04-034-3	Inside below
9	1	PNT-02-3LB-031-3	Airbag rocker I
10	1	PNT-02-3LB-033-3	Airbag rocker II
11	1	PNT-02-3LB-035-3	Airbag rocker III
12	1	PNT-02-3LB-037-3	Airbag rocker IV
13	1	PNT-04-031-3	Lower frame
18	1	PNT-02-3LB-043-3	Cover plate

## 12.5 Painter 05

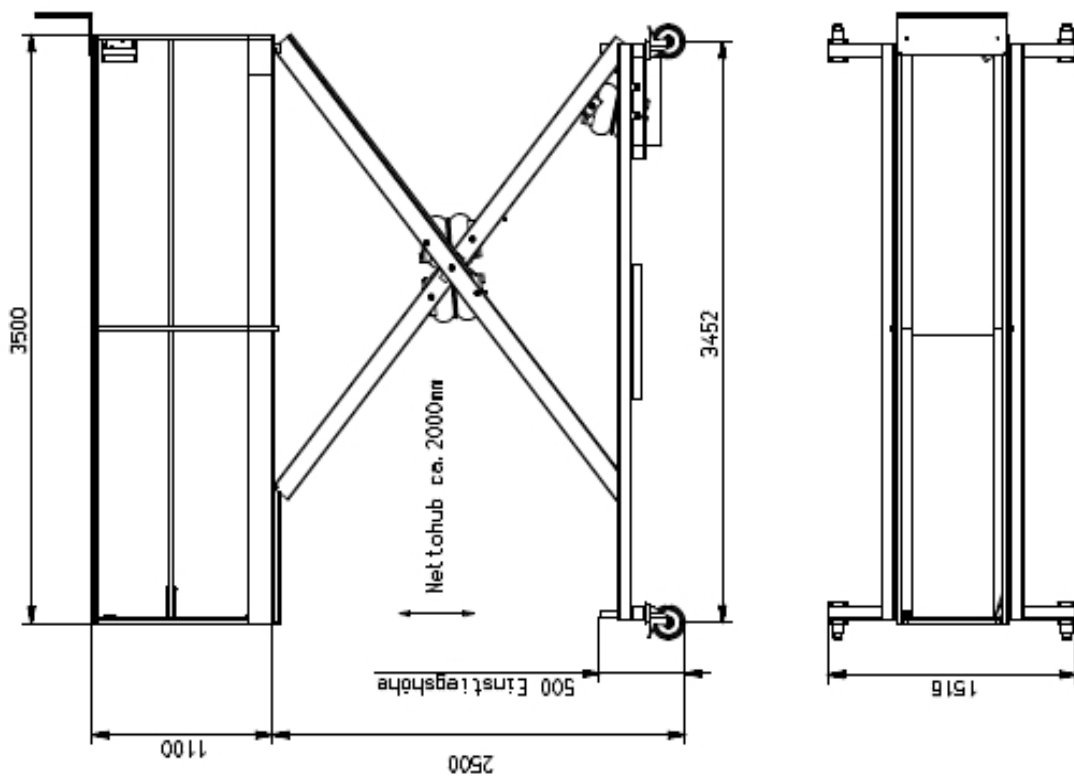
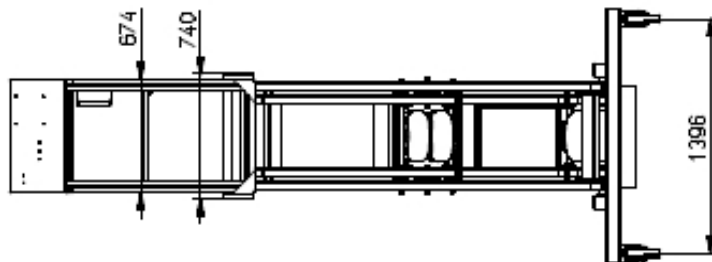

### Pneumatic drawing

See Page 33: Pneumatic drawing Painter 02.

### Hand lever valve

See Page 35: Hand lever valve Painter 02.

### Composition

See Page 36: Composition Painter 02

## 12.6 Painter 06

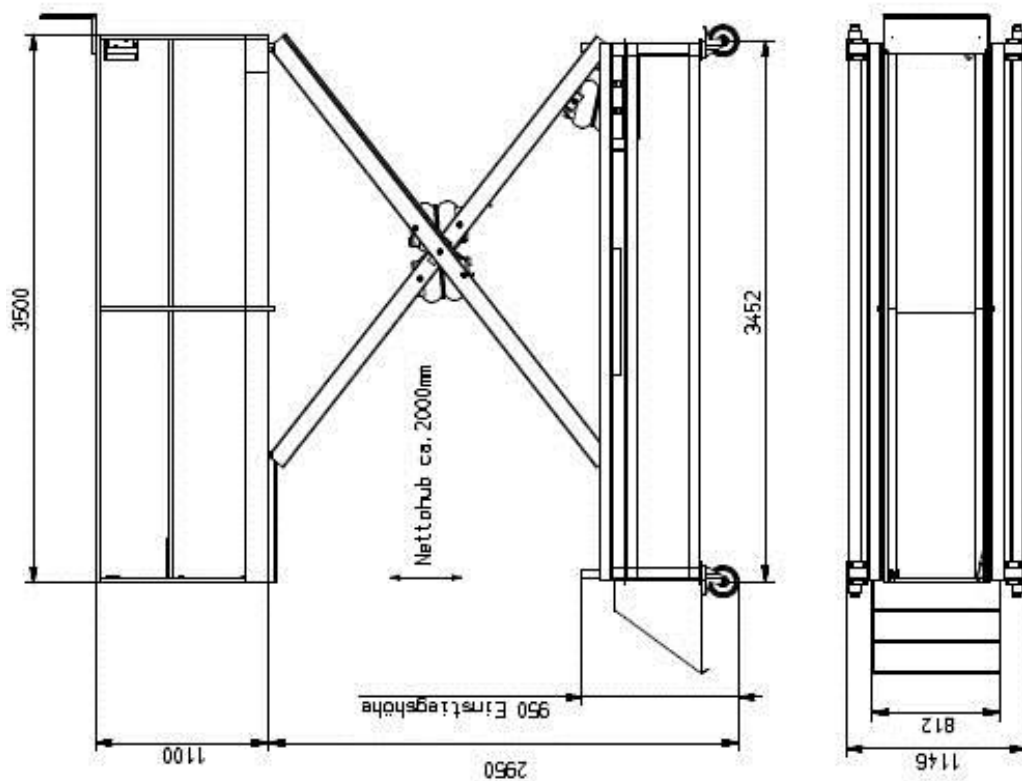
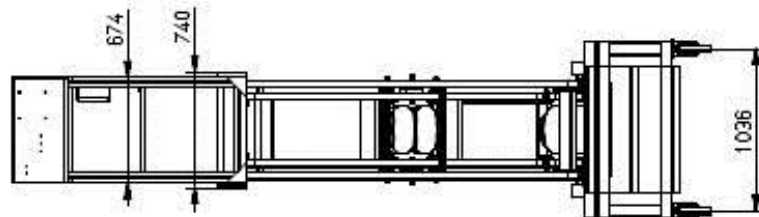

### Pneumatic drawing

See Page 33: Pneumatic drawing Painter 02.

### Hand lever valve

See Page 35: Hand lever valve Painter 02.

### Composition

See Page 36: Composition Painter 02.

## 12.7 Painter 07

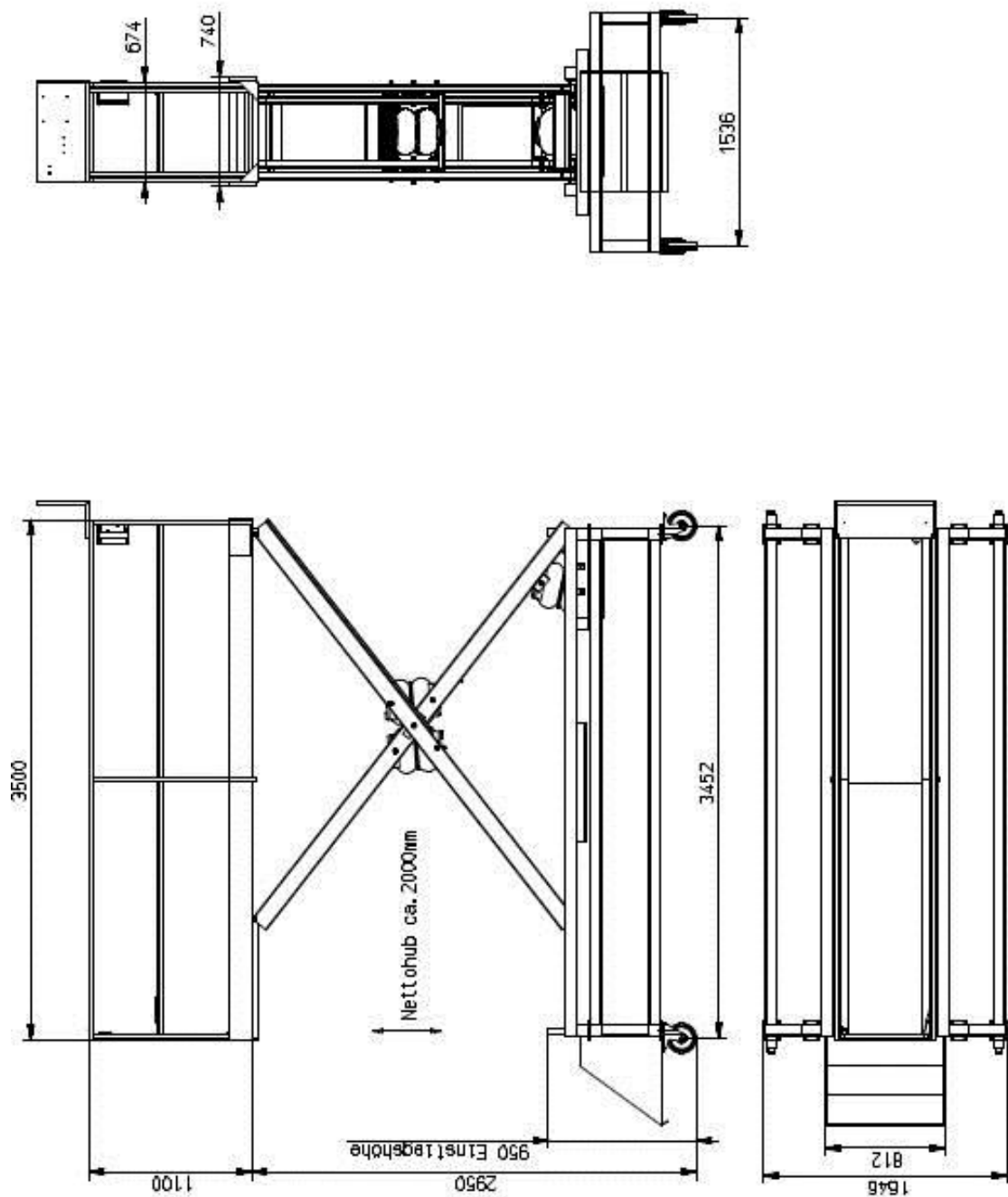

### Pneumatic drawing

See Page 33: Pneumatic drawing Painter 02.

### Hand lever valve

See Page 35: Hand lever valve Painter 02.

### Composition

See Page 36: Composition Painter 02